

**FIMER**



# AC Charging Solutions

## AC-EVC

**E-Mobility**

# FIMER: ready for the future

In a global scenario where the demand for renewable energy is constantly growing, FIMER is a leading global manufacturer of inverters.

Taking advantage of its experience in the development of inverters, since 2017 FIMER has been actively involved in creating the charging station network and today it has a key role in the manufacturing of the electric vehicle recharging stations.

Our approach based on constant innovation has enabled us to build a significant market share, with a focus on our

research centers specializing on solar and electric mobility. We have built a strategic vision for a sustainable world.

FIMER has over 1100 employees worldwide and offers a comprehensive solar solutions portfolio across all applications. With a presence in 26 countries together with local training centers and manufacturing hubs, FIMER remains close to its customers and the ever-evolving dynamics of the energy industry.

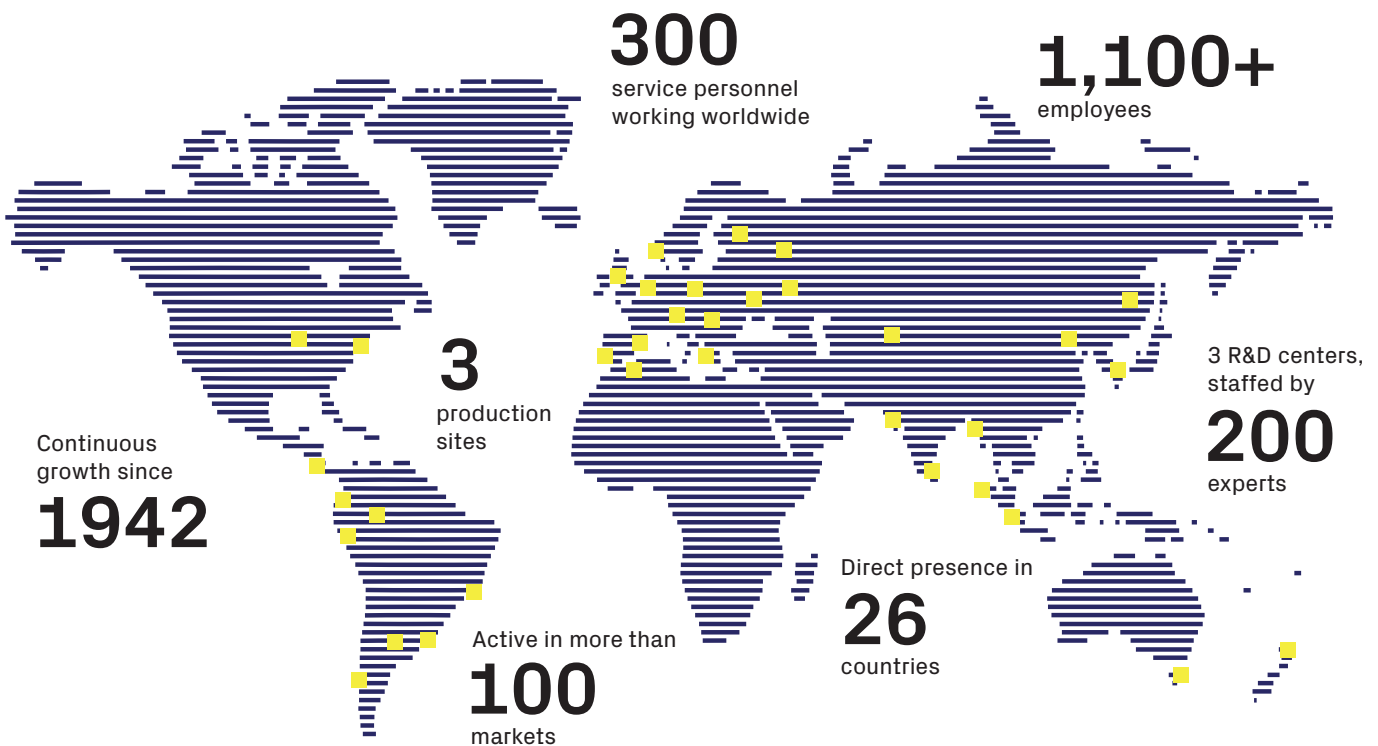

## For a supercharged electric mobility



Active in creating the EV charging station network since **2017**



More than **23,500** charging stations



FIMER



CHARGING  
STATION



AC-EVC

FIMER



# E-Mobility department AC Recharge systems

From the strategic global partnership with the most advanced utilities, since 2018 the E-Mobility division takes an active part for the realisation of the electric vehicle recharging stations.

The national and international scenario creates the conditions for enhancing diffusion of electric vehicles, with exponential growth rates in terms of amount of vehicles and technological developments. Car manufacturers have taken a strategic decision, declaring total or partial conversion into the electrical system of their range of vehicles model within a few years.

Our R&D approach for constant innovation in our international research centers ensures continuous portfolio renewal with cutting-edge technology. Highest quality and testing standards guarantee highly reliable solutions that are market-leading in the industry.

Custom projects have been accomplished for our main Customers present on the market.



# AC Recharge Systems

AC charging stations (up to 22 kW) are commonly called "charging points" and must guarantee vehicles a recharge in places where the vehicle normally stops such as public places (roads and parking), semi-public (for ex. paid parking) or even private ones.

These systems meet the basic needs for the majority of the users since the autonomy of the batteries recharged in average parking exceeds the daily distance.

Considering a vehicle with a 50 kWh battery pack, it will be able to perform a full charge with a AC system (22 kW) in about 2.5 hours. In the case of vehicles with 100 kWh batteries, it will be able to perform a full charge in about 5 hours.

The actual power of the recharge depends on the power of the on board battery charger, which performs the AC / DC conversion and charge the lithium ion battery normally used on contemporary cars.

The AC-EVC product line allows to charge electric vehicles in recharging mode 3 – case B .

The product is equipped with 2 AC socket type 2.

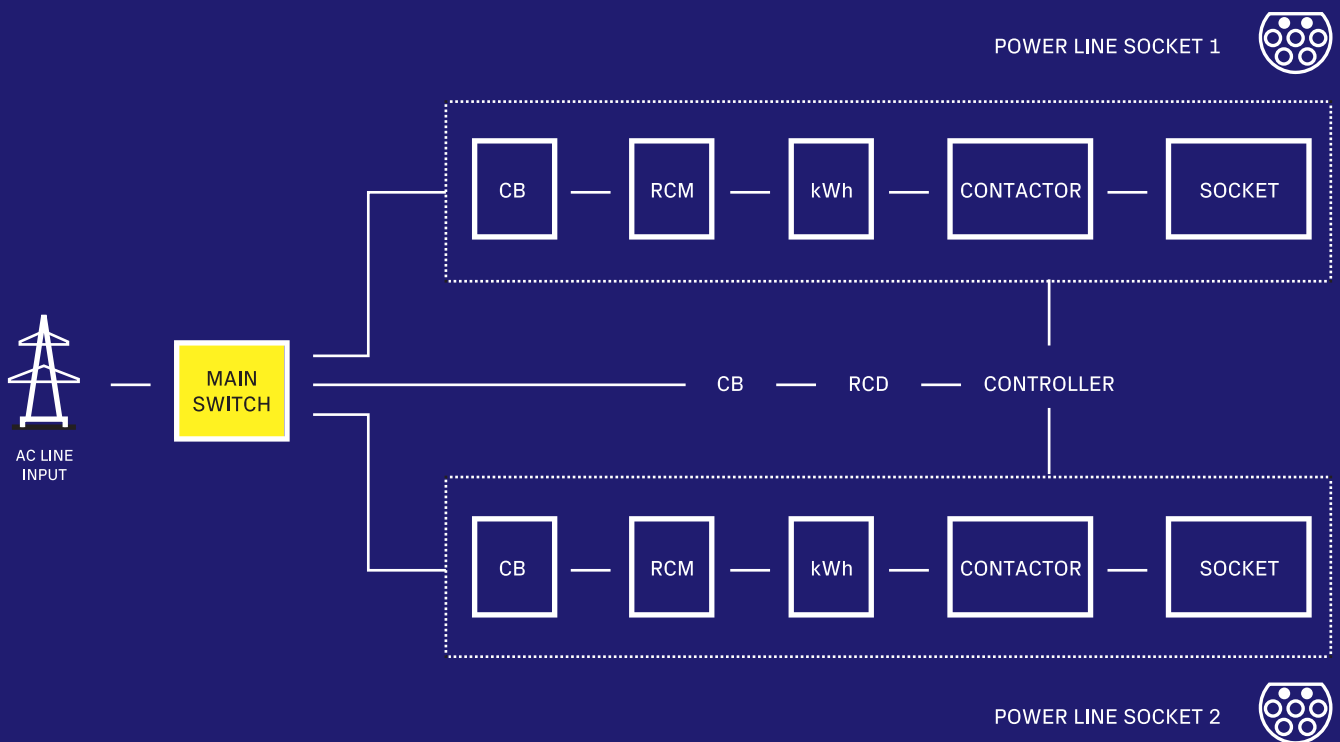
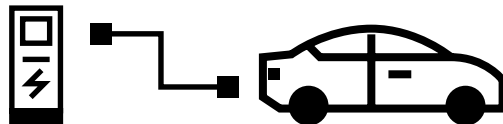

FIMER AC-EVC charging stations are equipped with a electronic controller designed to perform monitoring, controlling and communication tasks.

The controller is designed and manufactured by FIMER R & D

department based on the extensive experience in industry, energy conversion and electricity transmission; ensures functionality and robustness because of a simple and effective design, compatible with all the future technological developments of the vehicle recharging stations.

# AC EV Charger Range

The FIMER AC EV Charger line design is based on solidity, functionality and maintainability, in compliance with the international IEC 61851-1 standard. It is a charging point able to recharge up to two electric vehicles in alternating current, each up to 22kW, which can be configured in different ways.

**Island mode** (Stand-Alone), where the charging point provides the maximum power required by the vehicle, according to the recharge, protection and network conditions.

**Local control mode**, where the charging station is equipped with a local recognition system whether to allow individual charging or not, in order to manage efficiently every aspect of security and authorizations in a non-invasive way.

**Networked mode**, where the charging point is intelligently connected to a centralized system through an internet connection, through which you can manage the authorizations, the accounting, the permits and payments of energy.

The FIMER AC-EV charging points are made of durable materials, designed to withstand the weather conditions of an outdoor installation and ensure an extremely simple use both for the user and for the maintainer. In fact, the electronic control devices are accessible separately from the power parts, with great advantages in terms of safety and robustness.

AC-EVC-010

## Stand Alone

It is a charging unit for stand-alone installation and charging in AC Mode 3 with power up to 2x22kW in basic configuration, aesthetically appealing, sturdy, designed for maximum simplicity of use.

The charging unit is designed in accordance with the current legislation and it is the most reliable solution in order to offer free recharging stations, typically in environments semi-public or private, such as parking lots. It is equipped with a series of:

- Up to two Type 2 sockets, equipped with all the measurement and protection systems, electromechanical retention during charging, communication with the electric vehicle, connection monitoring and regulation of the current through PWM and differential protection circuit breaker type B.
- Color-coded Status LED for each socket (Ready to use, Charging, Alarm, etc ...)
- Smart fault management, with automatic reclosure of the circuit breaker.
- Internal load manager for the distribution of the maximum load set by the user, between the two sockets.
- Plug & Charge operation mode.
- Back-up power supply with super "Supercap" capacitors.
- Internal temperature sensors.
- Stainless steel case.



2x22 kW

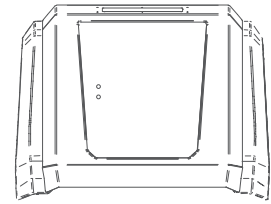



AC-EVC-020

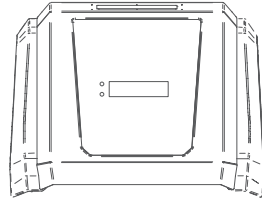

## Local Controller

It is a charging point equipped with all the features of the Stand-alone one, with some additional features, which allow the installation of multiple devices interconnected.

- Up to two Type 2 sockets, equipped with all the measurement and protection systems, electromechanical retention during charging, communication with the electric vehicle, connection monitoring and regulation of the current through PWM and differential protection circuit breaker type B.
- Color-coded Status LED for each socket (Ready to use, Charging, Alarm, etc ...)
- Smart fault management, with automatic reclosure of the circuit breaker.
- Internal load manager for the distribution of the maximum load set by the user, between the two sockets.
- Plug & Charge operation mode.
- Back-up power supply with super "Supercap" capacitors.
- Internal temperature sensors.
- Stainless steel case.
- OLED display with status, kWh counter, instantaneous kW, etc ...
- RFID reader for user authentication and recharge management.



2x22 kW



Display OLED



RFID

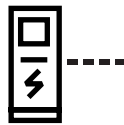

Remote

AC-EVC-030

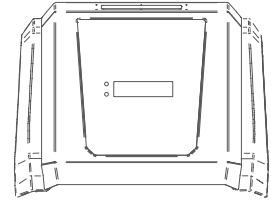

## Future Net

It is a charging point equipped with the previous configuration features, also allows to be customized according to the needs of the customer. It is therefore equipped with:

- Up to two Type 2 sockets, equipped with all the measurement and protection systems, electromechanical retention during charging, communication with the electric vehicle, connection monitoring and regulation of the current through PWM and differential protection circuit breaker type B.
- Color-coded Status LED for each socket (Ready to use, Charging, Alarm, etc ...)
- Smart fault management, with automatic or remotely controllable reclosure of the circuit breaker.
- Internal load manager for the distribution of the maximum load set by the user, between the two sockets.
- Plug & Charge operating mode.
- Back-up power supply with super "Supercap" capacitors.
- Internal temperature sensors.
- Stainless steel case.
- An intelligent remote monitoring and control system with an app for the customer and with a dashboard for the operator, with accounting energy, which will allow the roaming between various operators.
- OLED display with status, kWh counter, instantaneous kW, etc ...
- RFID reader for user authentication and recharge management.
- Aesthetic customization (optional).
- Optional remote monitoring capabilities via modem with OCPP 1.5 / 1.6 protocol compatible with all recharging point monitoring platforms.



2x22 kW



Display OLED



RFID

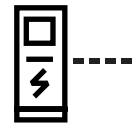

Remote

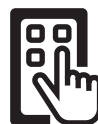

App



OCPP

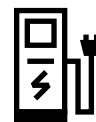

Custom

# Where you can recharge



## At home

Our charging station can be installed for private use in your garage or garden.

## At home - condominium

Charging station for indoor or outdoor use, installed in a private car park.

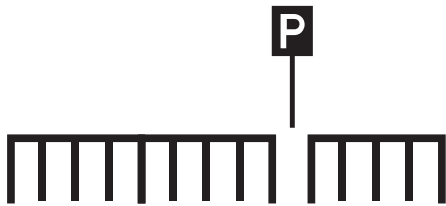

## In public parking

Public parking providers often offer charging stations with the aim of meeting new customer needs. It is generally possible to access it with a badge according to various commercial conditions.

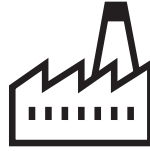

## At work

An increasing number of companies have installed charging stations in their own parking offering the possibility to recharge for free or pay a fee.

Generally several state or governmental structures allocate parking areas completely equipped to charge their electric vehicles; our charging station can be easily installed in these areas as well.



## In the street

The charging stations are accessible via badge or via a smartphone app, according to various commercial conditions and to the operator's platform.



# Integrated solutions

**FIMER recharging systems are created to communicate in different ways, taking advantage of the largest possible connectivity: it is possible to communicate with the user through information exchange and localized control, for example via RFID technology; obviously remote connection is expected to be provided via UMTS modem, enabling to monitor and control an infrastructure which by definition is distributed in the area.**

Thanks to the open system architecture, recharging stations could also be integrated with any parking automation systems, in order to standardize access and payment control systems on only one network.

For a private or condominium use, the devices can be calibrated allowing to manage the maximum power available and that absorbed according to logic customized, according to user requirements and to the characteristics of the local electrical system.

whatever the chosen solution, the charging points will always measure and collect in real time per user the data during the charging, such as charging time, energy consumed, maximum power input, allowing to check in real time all the charging parameters.

FIMER devices are compatible with all the main platforms developed with the most common communication protocol (OCPP 1.5 / 1.6J); these technology platforms enable these technology platforms enable all parties involved in keeping the process under control.

The users can have access to the recharge options, while the system tracks all the measures and information relevant for the correct operating status of the charging stations.

In the meantime, the manager can collect data and supervise the infrastructure, as well as the maintenance technician can take prompt action if necessary or, for example, in case of firmware updates.

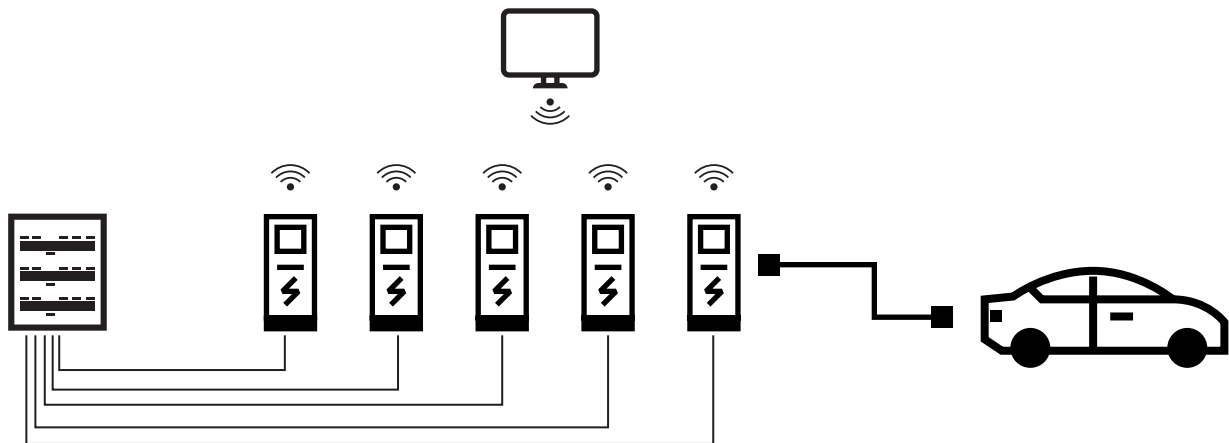

# AC Charging stations

	AC-EVC-010	AC-EVC-020	AC-EVC-030
Charging mode / case	<b>Mode 3, case B (Note 1)</b>		
Type of sockets	<b>Type 2 (Note 2)</b>		
Maximum AC power	<b>2x22 kW</b>		
Operating voltage	3x 400VAC +/-10% (50 o 60 Hz)		
Maximum current deliverable	<b>32A</b>		
IP protection class	IP 54		
Casing material	Stainless steel AISI 304		
IK protection class (external impacts)	IK10		
Dimensions	1315x437x293		
Weight	48 Kg		
<b>ENVIRONMENT DATA</b>			
Operating temperature	<b>-25°C ... 50°C</b>		
Storage temperatures	-25°C ... 70°C		
Humidity	0 % ... 95 % (without condensation)		
Altitude	Up to 2000m		
Type of installation	Suitable also for outdoor installation		
<b>INTERNAL COMPONENTS</b>			
Circuit breaker protection switch	4X D40		
Leakage detect protection	According to IEC 61851, made by RCM (RCD Type B optional)		
Energy Meter	MID certified 3ph + N 3x400/230V kWh Class B (Note 3) kWh Class 1 (Note 4) kVar Class 2 (Note 5) RS485 monitor		
Contactor	4xNO 40A, AC-1 @40°C Aux Contact 1xNO + 1xNC		
Plug-socket	PWM-CP, PP (Note 1)		
<b>ELECTRONIC CONTROL BOARD</b>			
Board power supply voltage	24 VDC ±5%		
Internal diagnostic systems	Measurement of all internal tensions Monitoring of internal temperatures Monitoring of the status of the contactor and of the circuit-breaker Ground fault reclosure system Monitoring of electromechanical component states		
Electronic control board	Microprocessor		

Nota 1: According to IEC 61851-1.

Nota 2: According to IEC 62196-2.

Nota 3: According to EN50470-3.

Nota 4: According to EN62053-21.

Nota 5: According to EN62053-23.

# Data Sheet

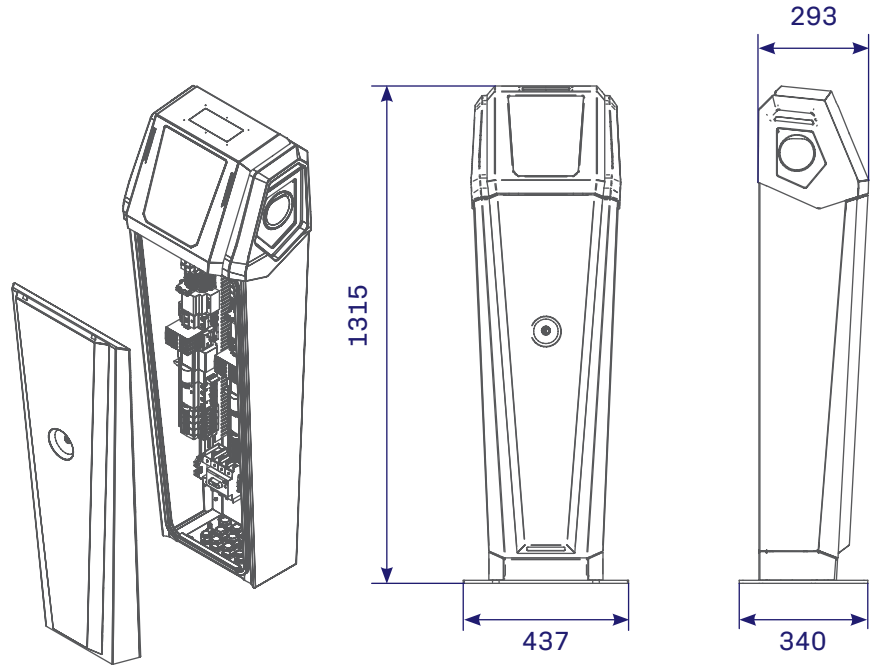

	AC-EVC-010	AC-EVC-020	AC-EVC-030
Charging sockets equipped with protection and safety systems	●	●	●
Automatic re-close differential breaker	●	●	●
Type 2 socket for electric vehicles with vandal-proof	●	●	●
Internal Load Manager	●	●	●
External management system	-	MODBUS TCP/IP	MODBUS TCP/IP - OCPP
Internal diagnostics system with "maintenance portal"	-	-	●
<b>SIGNALING AND CONTROL</b>			
Status LEDs and light signaling	●	●	●
Display OLED 2x22 characters	-	●	●
Authentication and unlocking systems via RFID	-	●	○
<b>TYPES OF CONNECTORS</b>			
Type of socket / connector	Type 2 IEC/EN 62196-2		
Station fixed socket			
Note	Connector used for AC recharging up to 22 kW		



FIMER S.p.A.  
Via J.F. Kennedy – 20871 Vimercate (MB) – ITA

T +39 039 98981  
F +39 039 6079334  
info@fimer.com

[www.fimer.com](http://www.fimer.com)