

FIMER

REACT 2

AN - Backup output

Contents

03	Scope and field of application
	Overview
04	Backup output working mode
	- Auto
05	- Ext. Control / Digital control
06	General recommendations
07	Backup output - Specifications
08	- Protections
	- Backup line / Schematic
09	Priority load activation devices (priority box)
	- Priority box - Automatic activation – Two poles
10	- Priority box - Automatic activation Single pole breaker. (E.g. Australia)
11	Settings of backup working mode
	- Step by step process og Backup settings



Each operation on the REACT2 system, shown in this document, must be performed in compliance with the safety measures recommended by the local legislation in force.

Before performing any action in the inverter terminal block, make sure that the unit is completely OFF with both AC and DC disconnected).

Version	Date	Note
V1	07/07/18	First Release
V2	10/06/20	FIMER rebranding, general adjustment

Scope and field of application

The purpose of this document is to describe the backup output operation available in the inverter models listed in Table 1

Models

REACT2-UNO-3.6 -TL (with or without REACT2-BATT)

REACT2-UNO-4.6 -TL (with or without REACT2-BATT)

Table 1 - Inverter models with backup output

Overview

The REACT 2 system provides a voltage source output, with dedicated terminals, working alternatively to the grid output. With alternatively we intend that grid interface contactors and backup interface contactors cannot be closed at the same time. The switchover time between grid and backup operation is lower than 30 seconds (it may vary based on solar, battery and grid conditions).

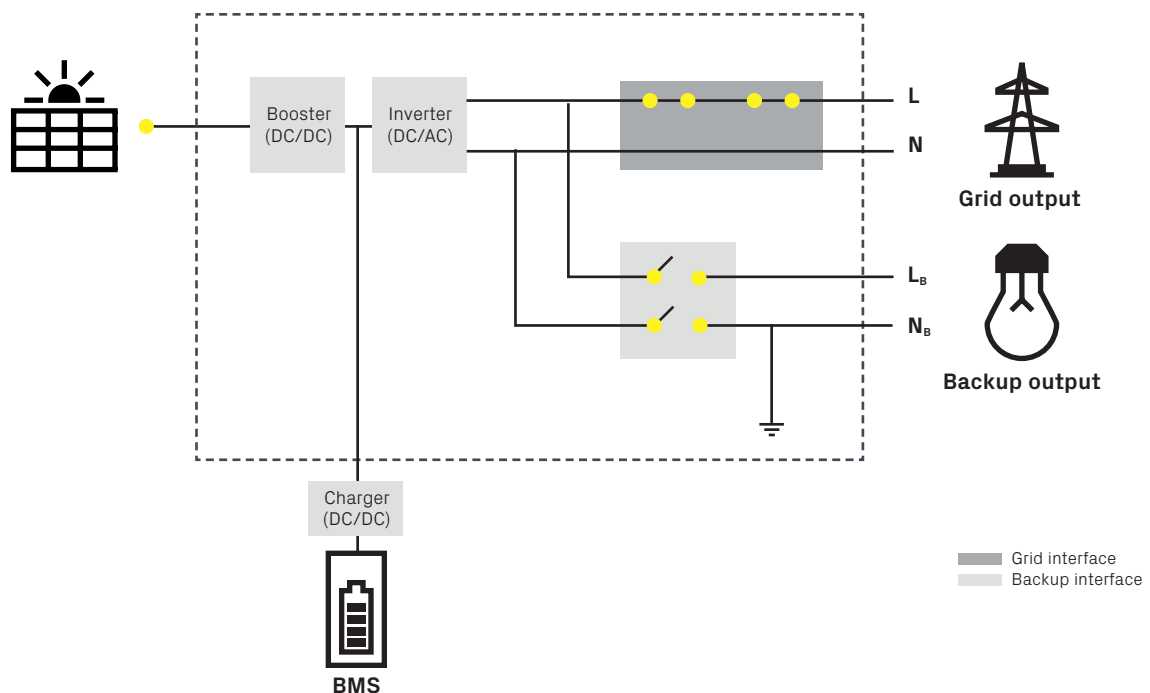

Figure 1 - Schematic block of REACT 2 outputs

Three types of loads are identified in an environment where REACT2 can be installed:

Grid only loads

Loads/appliances are connected exclusively to the electrical grid. They will never be fed by the backup output in case trigger condition occurs.

Backup only Loads

Loads/appliances connected exclusively to the backup output. They will never be fed when trigger condition occurs. Typical loads to be fed by backup outputs are emergency lights.

Priority/critical loads

Loads/appliances connected to the electric grid or to backup line based on trigger condition occurrence. An external box is required to use priority/critical loads with REACT 2 systems. Typical loads to be fed by the priority box are refrigerators, freezers and so on...

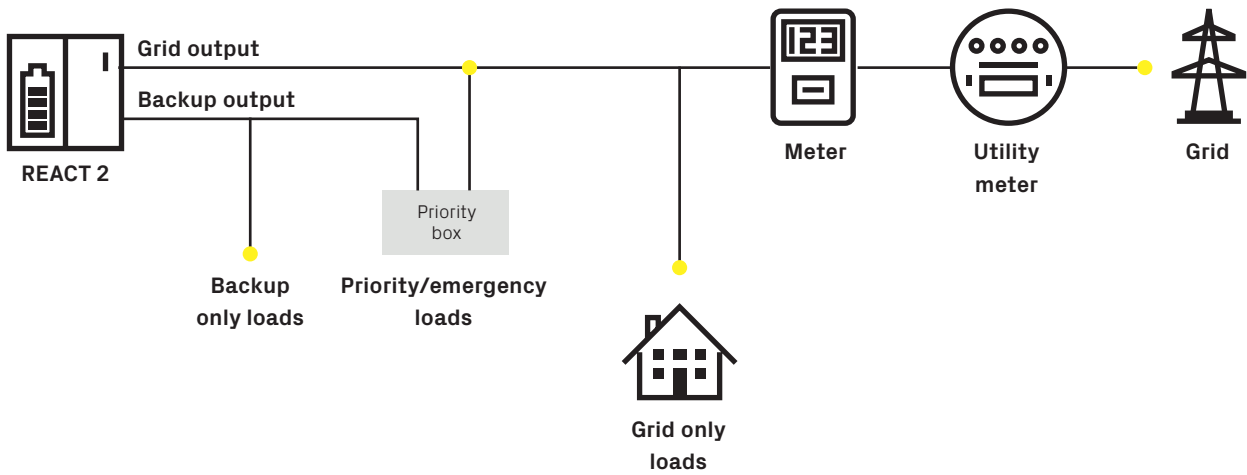

Figure 2 - Typical loads in plants with REACT 2

Backup output working mode

Backup output has two alternative working modes called Automatic and External control. The selection can be done via REACT 2 user interfaces (see paragraph Settings of backup output working mode).

The two alternatives have different triggers for the backup activation/deactivation. See Table 2 for further details.

	Trigger	Activation	Deactivation
Auto	Voltage at inverter grid output*	Absence	Presence
Ext.control	Digital input (BKP)	Short circuit	Open circuit

Table 2 - backup output triggers

Auto

In automatic mode, the inverter may activate backup output if and only if:

ACTIVATION CONDITION - grid (voltage and frequency) absence at inverter grid output

Three scenarios describe the conditions leading to the backup activation or not in automatic working mode. They are summarized in Table 3. P icons represent protections (CB and/or RCDs).

Scenario	Condition	Backup activation
	Power outage (Black out)	Yes
	Inverter circuit breaker is tripped	Yes
	House circuit breaker is tripped	No

Table 3 - Automatic mode - scenarios

To get the inverter stops to work in backup mode, the following conditions shall be respected::

DEACTIVATION CONDITION - grid voltage gets back to inverter grid output

When the deactivation condition occurs, the inverter:

- opens the backup interface contactors
- check the grid conditions (ensuring voltage and frequency parameters are in the range)
- closes the grid interface contactors

Ext.Control

With external control mode, the inverter may activate backup output if and only if:

ACTIVATION CONDITION - Pins 1 and 3 of J3 terminal block are in short circuit

When activation condition occurs, the inverter will disconnect itself from the grid (it opens the grid interface contactors and closes (after few seconds) the backup interface contactors).

To get the inverter stops to work in backup mode, the following condition shall be respected:

DECTIVATION CONDITION - Pins 1 and 3 of J3 terminal block are in open circuit

When the deactivation condition occurs, the inverter:

- opens the backup interface contactors
- check the grid conditions (ensuring voltage and frequency parameters are in the range)
- closes the grid interface contactors

Ext. Control – Digital input

To use external digital control the user has to connect terminals 1 and 3 of J3 terminal block as shown in Figure 3.

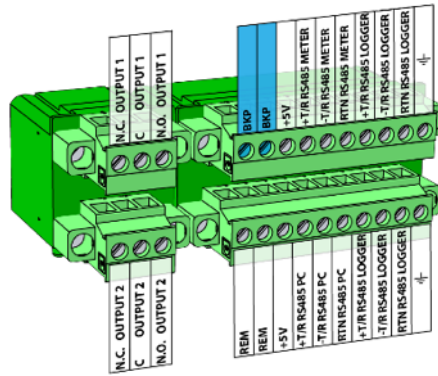

Figure 3 - External control digital input location (BKP)



Before performing any action on the terminal block, make sure REACT 2 is completely OFF. Refer to the product manual for details

Since BKP input is a digital input, there are no instructions on the size of the cable to be used (just comply with the recommended sizing for the passage of cables on the cable glands and terminal block).



- The backup line must be sized and designed in a workmanlike manner, in compliance with the applicable legislation in force in the place where the system is installed.
- Do not connect any load requiring uninterruptible supply.
- Backup output works if enough power from solar and battery is available
- Backup shall not be considered as a critical port nor as an uninterruptible power supply (UPS) installed.

General recommendations

For safety reasons, it is mandatory to clearly label and identify the circuits/loads being supplied by backup output as they will automatically be powered even when the grid fails.

All the sockets connected to the backup output should be marked with an identification label (color), with indication, in the main switchboard, of the presence of an alternative source of power to the distributor's grid.

As per emergency/UPS systems, the presence of any dangerous voltage in the circuit must be indicated to prevent risks in case of actions and operations on the electric system. We recommend using warning methods like the one shown in the figure:

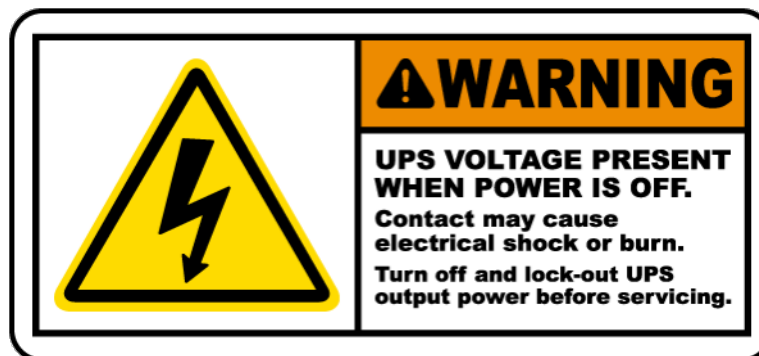

Backup output - Specifications

The backup output terminal block (42 in Figure 4) is accessible opening the frontal cover of REACT 2 and passing cables through the BACKUP cable gland (see REACT 2 manual for details).

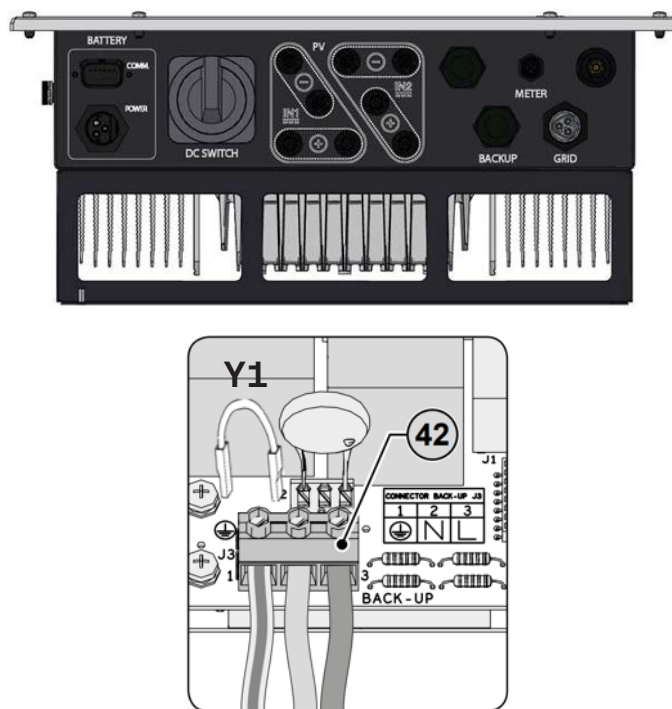

Figure 4 - Backup output terminal block

Three connections are required to connect the backup output: Phase, Neutral and Earth, with a cable of a maximum size of 4 mm² (the connection of the earth wire is mandatory).

The electrical characteristics of the backup output are indicated in the Table 4.

Maximum Apparent Output Power (S_{acr})	3000 VA
Rated AC output Voltage (V_{acr})	230 V (1Ø)
Maximum output Current ($I_{ac\ max}$)	13 A
Rated output Frequency (f_r)	50 Hz
Maximum output fault current	27 A rms (60ms)
Maximum AC overcurrent protection	16A

Table 4 - Backup output - Electrical characteristics

We recommend sizing conductors based on the line length to limit voltage drop at the load terminals, and, therefore, avoid any unwanted disconnection of the loads/appliances connected to the backup source. Please take Table 5 as a reference:

Conductor size (mm ²)	Maximum length of conductor (m)
>1.5	6
>2.5	11
>4	19

Table 5 - Backup output – Sizing of the line conductor

The values are determined in nominal power conditions by considering:

- max 1% loss of power along the line
- copper cable used with HEPR rubber insulation, laid in free air



Backup output line must be protected by means of a residual current circuit breaker (RCD).

Protections



To make sure the RCD works properly, a secure connection between neutral (NB) and ground (PE) is established via factory installed jumper Y1.

Type	Circuit breaker with differential magnetic-thermal protection
Voltage rating	230 V _{ac}
Current rating	16 A
Magnetic protection charact.	B/C
Type of differential protection	A/AC
Differential sensitivity	30 mA
Number of poles	2

Table 6 - Backup output – Required external protections

Backup line – Schematic

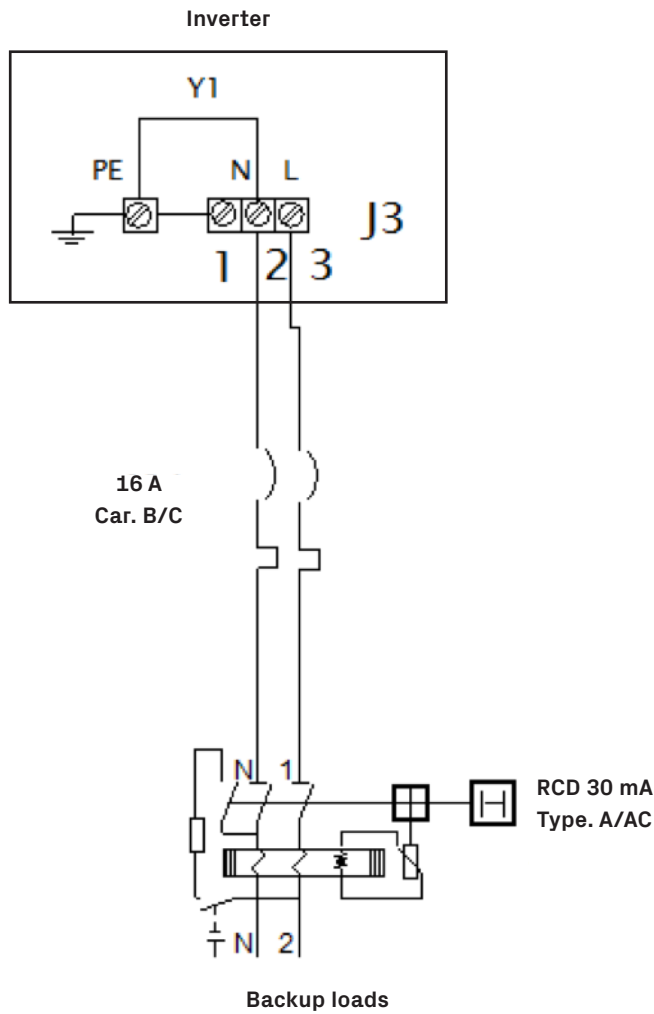

Figure 5 - Example of Backup line including protections

Priority load activation devices (priority box)

A dedicated circuit shall be designed to use the REACT 2 backup output for priority load activation.

We suggest using two electrical interlocked contactors maintaining separation between backup line and distributor grid in every condition.

Some examples are shown in the following paragraphs.



Make sure to follow your country's safety and electrical regulations to dimension priority load circuit/protections properly

Priority box - Automatic activation – Two poles

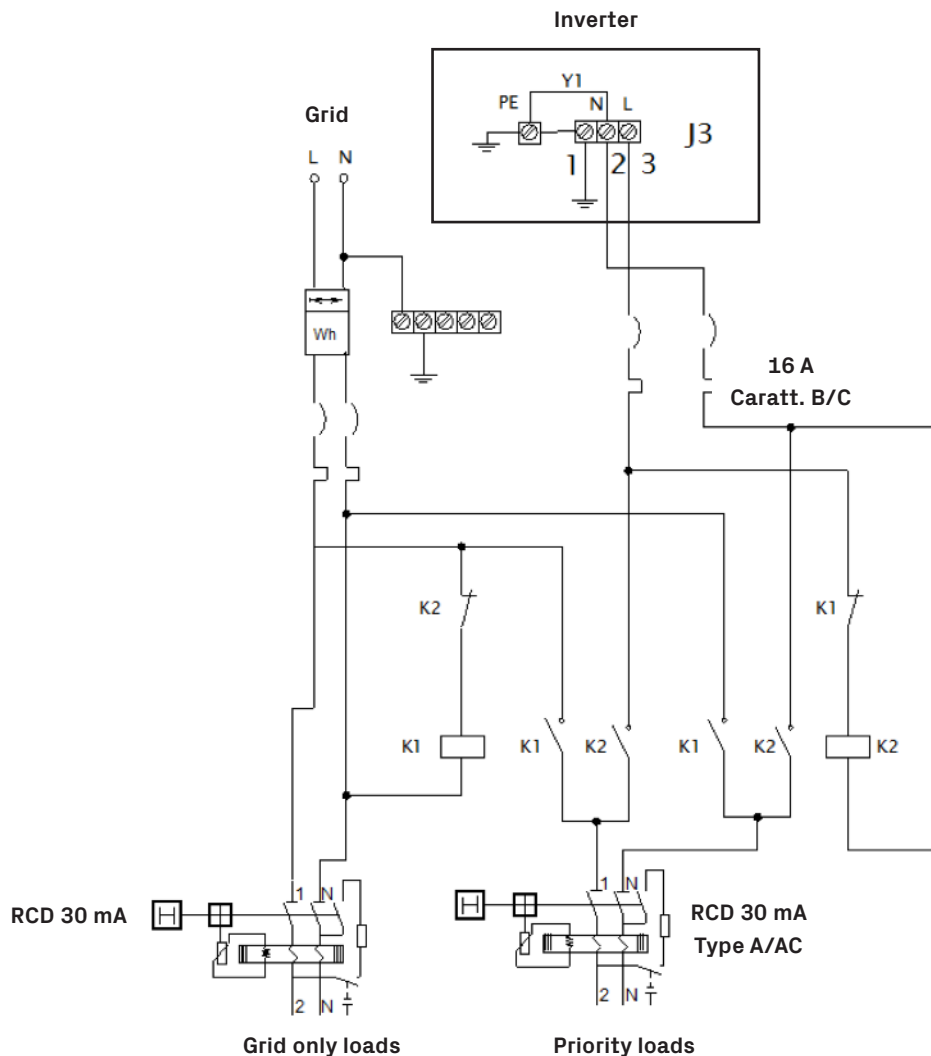

Figure 6 - Example of priority box with two poles breakers

Contactors K1 and K2 have two Normally open (NO) and one Normally closed (NC) contacts. The schematic above represents the condition with not energized contactors (No grid voltage, No backup voltage presence).



Priority loads power consumption shall respect backup output power limit to avoid undesired REACT 2 disconnection due to overload.

Priority box - Automatic activation – Single pole breaker. (E.g. Australia)

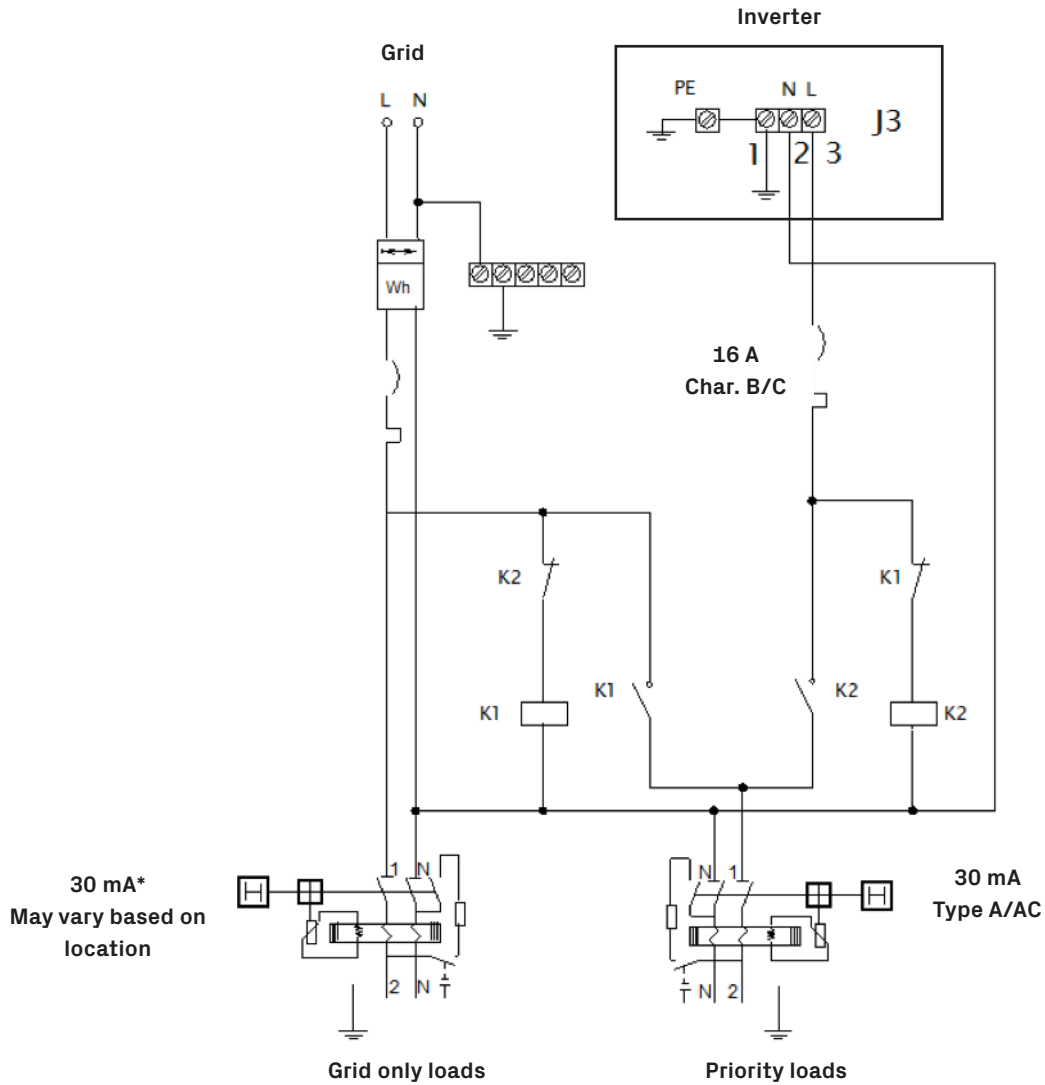

Figure 8- Example of priority box with two poles breakers

Make sure to remove the Jumper Y1 (between neutral (NB) and ground (PE)) to avoid two Multiple Earthed Neutral (MEN) Link



Remove connection Y1 (neutral (N) and ground (PE)) ONLY if it required by National regulation.

Contactors K1 and K2 have two Normally open (NO) and one Normally closed (NC) contacts. The schematic above represents the condition with not energized contactors (No grid voltage, No backup voltage presence).

Settings of backup working mode

Backup working mode can be set during the commissioning of the REACT 2 (see product’s manual for details) or later by using the embedded web server user interface. Preset factory value is “None”, meaning that backup output is not active by default.

The user should consider another important parameter in case of battery presence:

Battery % for Backup

Battery capacity reserved for operation in backup (default: 5%).

During normal operation “Grid connected”, this battery capacity will never be used.

E.g assuming a system with a 4 kWh battery and Battery % for Backup=50% means that the inverter uses 2 kWh for grid connected applications. It will use the remaining 2 kWh if the backup activation condition occurs only.



Raccommodation

Increase the Battery % for Backup if weak grid is present in your area only. Otherwise keep it lower to maximize the battery usage for improving customer self-consumption quota..

Step by step process of Backup settings

Log in as Administrator in the webserver user interface of REACT 2 and follow these steps:



1 - Click on the hamburger icon

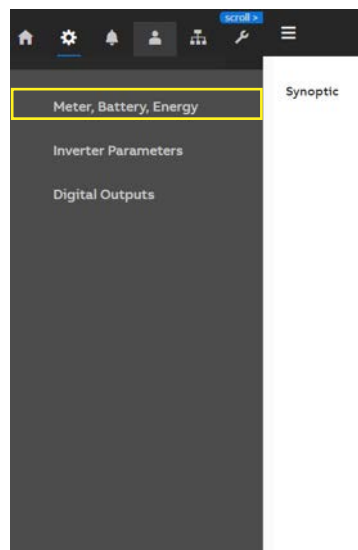

2 - Select Meter, Battery, Energy

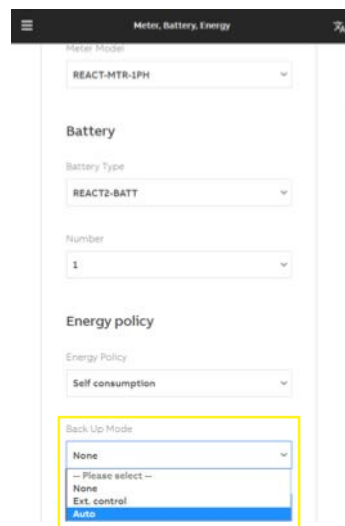

3 - Choose the desired backup mode