

FIMER



Product Manual

PVS-100/120-TL
(100 to 120 kW,
“B version”)

IMPORTANT SAFETY INSTRUCTIONS



This manual contains important safety instructions that must be followed during the installation and maintenance of the equipment.

SAVE THESE INSTRUCTIONS!



Keep this document in a safe place near the inverter for easy access during installation, operation and maintenance.

THE INSTALLER MUST READ THIS DOCUMENT IN ITS ENTIRETY BEFORE INSTALLING THIS EQUIPMENT.

Operators are required to read this manual and scrupulously follow the instructions given in it, since FIMER cannot be held responsible for damage caused to people and/or things, or the equipment, if the conditions described below are not observed.

The purpose of this document is to support the qualified technician, who has received training and/or has demonstrated skills and knowledge in construction, to install, operate and maintain the inverter. This manual covers only inverter, not any equipment (photovoltaic modules, external disconnects, etc) to which it is connected.

Warranty requirements are included in the Terms and Conditions of sale included with the inverter order.

NOTE: Any changes made to the product or to the installation conditions that hasn't been approved by FIMER will void the warranty.



All pictures and illustrations shown in this user manual are indicatives and must be intended as support for installation instruction only. Actual product may vary due to product enhancement. Specifications subject to change without notice. The latest version of this document is available on the FIMER website.



The products are designed to be connected to and to communicate information and data via a network interface. It is the user's sole responsibility to provide and continuously ensure a secure connection between the product and the user's network or any other network (as the case may be). The user shall establish and maintain any appropriate measures (such as but not limited to the installation of firewalls, application of authentication measures, encryption of data, installation of anti-virus programs, etc) to protect the product, the network, its system and the interface against any kind of security breaches, unauthorized access, interference, intrusion, leakage and/or theft of data or information. FIMER and its affiliates are not liable for damages and/or losses related to such security breaches, any unauthorized access, interference, intrusion, leakage and/or theft of data or information. The data, examples and diagrams in this manual are included solely for the concept or product description and are not to be deemed as a statement of guaranteed properties. All persons responsible for applying the equipment addressed in this manual must satisfy themselves that each intended application is suitable and acceptable, including that any applicable safety or other operational requirements are complied with. In particular, any risks in applications where a system failure and/or product failure would create a risk for harm to property or persons (including but not limited to personal injuries or death) shall be the sole responsibility of the person or entity applying the equipment, and those so responsible are hereby requested to ensure that all measures are taken to exclude or mitigate such risks. This document has been carefully checked by FIMER but deviations cannot be completely ruled out. In case any errors are detected, the reader is kindly requested to notify the manufacturer. Other than under explicit contractual commitments, in no event shall FIMER be responsible or liable for any loss or damage resulting from the use of this manual or the application of the equipment.

Product manual

PVS-100/120-TL “B version” string inverters

1 - Introduction and general information

2 - Characteristics

3 - Safety and accident prevention

4 - Lifting and transport

5 - Installation

6 - Instruments

7 - Operation

8 - Maintenance

9 - Attachments

Table of Contents

Table of Contents.....	4
Safety and accident prevention	8
Safety information and instructions	8
Symbols and signs.....	9
Installation and maintenance safety	11
General safety information.....	11
Environmental conditions and risks	11
Electrical and thermal safety.....	12
Residual risks	13
Table of residual risks	13
Introduction and general information.....	14
Warranty and supply conditions.....	14
Not included in the supply.....	14
Scope and target audience.....	15
Purpose and document structure	15
List of appendix documents	15
Operator and maintenance personnel skills/prerequisites	15
Application area, general conditions	16
Intended or allowed use.....	16
Limits in field of use.....	16
Improper or prohibited use	16
Characteristics	17
General conditions	17
Identification of the equipment and manufacturer	18
Models and range of equipment.....	20
List of main reference components	21
Communication board.....	23
Characteristics and technical data.....	24
Tightening torques	26
Cable gland clamping range.....	26
Overall dimensions	27
Mounting bracket.	27
Efficiency curves	28
Power limitation (Power derating).....	29
Power reduction due to environmental conditions.....	30
Power reduction due to the input voltage	31
P- Q curve capability.....	32
Characteristics of a photovoltaic generator.....	33
Strings and arrays.....	33
Description of the equipment.....	34
Operating diagram (example).....	34
Mutual connection of multiple inverters	35
Notes on the system sizing.....	35
Functionality and components of the equipment	36
Highlights	36
Improved commissioning and maintenance.....	36
Aurora Vision® Plant Management Platform.....	37

Configurable relays	38
Remote switch-on/switch-off	38
Reactive power feed into the grid	38
Limiting the active power fed into the grid	38
Overvoltage surge arrester monitoring	38
Data transmission and control	38
Communication connection diagrams.....	39
Communication interface	39
Ethernet bus connection	39
Topographic diagram of the equipment	41
Safety devices.....	43
Anti-Islanding	43
Ground fault of the photovoltaic panels	43
String fuses	43
Overvoltage surge arresters	43
Other safeguards	43
Lifting and transport.....	44
General conditions	44
Transport and handling	44
Lifting	44
Unpacking and checking	44
Storage.....	45
Equipment weight	45
Types of lifting	46
List of components supplied	49
Kit of recommended spare parts.....	50
Installation	51
General conditions	51
Installation site and position.....	52
Wireless signal environmental checks.....	55
Installations above 2000 metres	56
Installations with a high level of humidity.....	56
Installations of IP66 protection covers for wiring box openings (long term installation).....	57
Mounting with a support bracket.....	58
Routing the cable to the inverter	67
Grid output connection (AC side).....	68
Characteristics and sizing of the protective grounding cable	68
Characteristics and sizing of the line cable	69
Load protection switch (AC disconnect switch)	69
Selection of differential protection downstream of the inverter	70
AC output cables connection	71
Operations preliminary to the connection of the PV generator.....	74
Checking of leakage to ground of the photovoltaic generator	74
Checking of strings voltage.....	74
Access the negative side string fuses board	
(-SX2, SY2 wiring box version only)	75
Checking the correct polarity of the strings and fuses installation	76
Input connection to PV generator (DC side)	77
Installation procedure for quick-fit connectors	79

String protection fuses	83
Sizing of fuses	83
Communication and control board	85
Connections to the communication and control board	86
Ethernet connection	87
Serial communication connection (RS485 - Slave mode).....	89
Serial communication connection (RS485 - Master mode).....	92
Remote control connection	93
Demand Response Mode 0 (AS/NZS 4777.2)	93
Configurable Relay connection (ALARM and AUX)	94
Instruments	95
General conditions	95
Description of the LED function	96
User interface	97
Measurement tolerance	97
Operation	98
General conditions	98
Commissioning	99
Commissioning via FIMER Installer for Solar Inverters mobile APP	100
Commissioning Via Web UI - Wireless connection	102
Power, Alarm, GFI LEDs behaviour	110
WLAN/LAN LED behaviour	112
Description of the Web User Interface	113
Access to the Web User Interface	113
Web User Interface menu structure.....	116
MAIN section.....	117
SETTING section	119
INVERTER Log Section.....	126
USER section.....	127
Connectivity section	128
SERVICE Tools section	135
INFORMATION Section	139
Maintenance	140
General conditions	140
Inverter total de-energization and safe access	141
Operator and maintenance personnel skills/prerequisites	141
Clothing and protection of personnel.....	142
Safety equipment and tools	142
Inverter total de-energization and safe access procedure	143
Routine maintenance	157
Troubleshooting	158
Web User Interface and wireless communication troubleshooting	158
Alarm Messages of the Inverter.....	160
Power limitation messages	167
Registration on “Registration” website and calculation of security token (Admin Plus)	168
Procedure for dismantling the equipment	171
Replacing cooling section	173
Replacing fan section (internal)	174
Replacing the DC surge arrester boards (-SX/SX2 models only)	175
Replacing the AC surge arrester cartridge (-SX/SX2 models only)	178

Replacement of the Memory board	179
Replacement of the COMM RS485 board	180
Replacement of the buffer battery	181
Verification of ground leakage	182
Behaviour of a system without leakage	182
Behaviour of a system with leakage	183
Measuring the isolation resistance of the PV generator.....	184
Storage and dismantling	185
Storage of the equipment or prolonged stop	185
Dismantling, decommissioning and disposal.....	185
<i>Attachments</i>	186
Port and network services used by the inverter.....	186
IP Network Services.....	186
Network Hosts.....	187
Inverter network configuration	187
Further information	188
Contact us	189

Safety and accident prevention

1

Safety information and instructions

This chapter contains the safety instructions which you must obey when you install and operate the inverter and perform maintenance operations on the inverter. Obey these safety instructions to prevent injury or death, or damage to the equipment.

The instructions provided in the manual do not replace the safety devices and technical data for installation and operation labels on the product, and they do not replace the safety regulations in force in the country of installation.







The operators must read and comply with the technical information and instruction provided in the manual and in the attached documentation.









FIMER accepts no liability for failure to comply with the instructions for correct installation and cannot be held responsible for the upstream or downstream equipment.

Specific safety information are provided during installation, commissioning and maintenance operation instructions. Always follow the reading order of instruction exactly as described in this manual.

Symbols and signs

In the manual and/or in some cases on the equipment, the danger or hazard zones are indicated with signs, labels, symbols or icons.

Symbol	Description
	It is mandatory to consult the manual or original document, which must be available for future use and must not be damaged in any way.
	General warning - Important safety information. Operations or situations in which staff must be very careful.
	Dangerous Voltage - Operations or situations in which staff must be very careful with regard to dangerous voltage levels.
	Hot parts - Risk arising from the presence of hot zones or zones with parts at high temperatures (risk of burns).
	Risk of explosion
	Risk of injury due to the weight of the equipment. Take care during lifting and transport
	The area marked with this sign must not be accessed or the operation described must not be carried out.
	Keep out of the reach of children
	Smoking and the use of naked flames is prohibited.
	It is mandatory to carry out the described operations using the clothing and/or personal protective equipment provided by the employer.
	WEEE logo. The product have to be disposed according to current legislation regarding the disposal of electronic components.
	Protection rating of the equipment according to IEC 70-1 (EN 60529 June 1997) standard.
	Point of connection for grounding protection.
	Permitted temperature range

Symbol	Description
	Risk of electric shock. The discharge time (quantified in the figure by the number XX) of the stored energy after de-energizing of the Inverter from both DC side and AC side.
	Direct Current
	Alternate current
	With isolation transformer
	Without isolation transformer
	Positive pole of the input voltage (DC)
	Negative pole of the input voltage (DC)
	Center of gravity of the equipment.
	Wear acoustic protection devices in order to prevent damage to hearing

Installation and maintenance safety

General safety information



Do not proceed with installation if the integrity of the equipment is compromised. Do not use the equipment if you find any operating anomalies.



Avoid temporary repairs. All repairs should be carried out using only genuine spare parts, which must be installed in accordance with their intended use.



The labels affixed on the equipment must strictly NOT be removed, damaged, defaced, hidden, etc.

Do not do work on the photovoltaic generator, or the inverter, or its input or output cables, when the inverter is connected to an electrical power system, or to the photovoltaic generator.

Before performing any maintenance operation on the inverter, follow this steps:



- **Prepare the work: Do an on-site Risk Assessment or Job Hazard Analysis** (Check for proper tools and PPE for the Job; Engage the person responsible for electrical equipment or system to review single-line, schematics, switching plans; Decide on the appropriate work methods and initiate the permit to work process).
- **Clearly identify the work location and equipment.**
- **Disconnect all sources and Secure against reconnection by means of a 'Lockout/Tagout' procedure to ensure it cannot accidentally become live.**
- **Verify the absence of operating voltage** (This must be by means of a proper test instrument).
- **Complete the permit to work and "Walk the Permit"** (Now we have verified a 'safe working area' it is time to validate the 'Permit to Work' and "Walk the Permit").

Refer to "Inverter total de-energization and safe access" chapter on this manual to know all detailed necessary steps to safely operate on the inverter.

Environmental conditions and risks



The device can be installed outdoors, but only in environmental conditions that do not prevent its regular operation. These conditions are listed in the technical data and in the installation chapter.



Do not open the front covers of the inverter when it is raining, or when sand or dust can blow into the unit. Water or sand in the inverter can cause damage in the unit. In the risk assessment prior any intervention on the equipment it is of paramount importance to evaluate the weather conditions. Any intervention on the inverter can be done only in case of dry environment. Don't proceed in case of rain (even light) or high humidity.



The device is not designed to operate in environments that are particularly inflammable or explosive.



In the event of fire, use CO2 extinguishers and auto-extraction systems to extinguish the fire in closed environments.



The installer or maintenance technician must always pay attention to the work environment, ensuring that it is well-lit and there is enough room to ensure an escape route.

Electrical and thermal safety



WARNING! Obey these instructions to prevent injury or death, or damage to the equipment. If you are not a qualified electrician, do not perform any electrical installation or maintenance work.



Obey all installation safety standards. This can require, among other things, the use of personal protection equipment (PPE), such as arc-proof clothing, arc-proof masks, protective footwear, insulating and protective gloves, eye protection and hearing protection. High power inverter installations have high fault currents.



Before you operate on the inverter, isolate the AC line cables from the electrical power system with the AC disconnect switch of the power system transformer (downstream the inverter). Also, isolate the inverter from the photovoltaic generator with the DC disconnect switch of the generator or by other means (upstream the inverter). The internal AC disconnect switch (if present) do not isolate the AC output cables and terminals of the inverter from the electrical power system. The internal DC disconnect switches (if present) do not completely isolate the DC input cables or terminals from the DC voltage supplied by the photovoltaic generator. **Refer to “Inverter total de-energization and safe access” chapter on this manual for further details.**



Do not work on the communication and control signal cables when power is applied to the inverter or to the external control circuits.



Do not perform insulation or voltage withstand tests on the inverter.



FIMER inverters must be earthed via the connection points marked with the protective earth symbol \oplus and using a cable with an appropriate conductor cross-section for the maximum ground fault current that the generating system might experience.



Do not switch-on the inverter with the front covers open, even during troubleshooting. The inverter front covers act as arc hazard protection. If a highly unlikely arc flash incident occurs when the inverter front covers are open, the arc-flash proof protection equipment might not provide sufficient protection for the operators.



When the device has just been switched off, it may have hot parts as a result of overheating of the heated surfaces (e.g.: transformers, accumulators, coils, etc.) so be careful where you touch.

Residual risks



Despite the warnings and safety systems, there are still some residual risks that cannot be eliminated.

These risks are listed in the following table with some suggestions to prevent them.

Table of residual risks

RISK ANALYSIS AND DESCRIPTION	SUGGESTED REMEDY
Noise pollution due to installation in unsuitable environments or where staff work permanently.	Reassess the environment or the place of installation.
Suitable local ventilation that does not cause overheating of the equipment and is sufficient not to create discomfort to people in the room.	Restore suitable ambient conditions and air the room.
External weather conditions, such as water seepage, low temperatures, high humidity, etc.	Maintain ambient conditions suitable for the system.
Overheating of surfaces at temperature (transformers, accumulators, coils, etc.) can cause burns. Also be careful not to block the cooling slits or systems of the equipment.	Use suitable protective equipment or wait for the parts to cool down before switching on the equipment.
Inadequate cleaning: compromises cooling and does not allow the safety labels to be read.	Clean the equipment, labels and work environment adequately.
Accumulation of electrostatic energy can generate hazardous discharges.	Ensure the devices have discharged their energy before working on them.
During installation, temporarily mounting the equipment or its components may be risky.	Be careful about and disallow access to the installation area.

Warranty and supply conditions

The warranty conditions (available on the official FIMER website) are considered to be valid if the Customer adheres to the indications in this manual; any condition deviating from those described herein must be expressly agreed in the purchase order.

FIMER declares that the equipment complies with the provisions of law currently in force in the country of installation and has issued the corresponding declaration of conformity.

Not included in the supply

FIMER accepts no liability for failure to comply with the instructions for correct installation and will not be held responsible for systems upstream or downstream of the equipment it has supplied.



It is absolutely forbidden to modify the equipment. Any modification, manipulation, or alteration not expressly agreed with the manufacturer, concerning either hardware or software, shall result in the immediate cancellation of the warranty.

The customer is fully responsible for any changes made to the system.

Given the countless array of system configurations and installation environments possible, it is essential to check the following: adequate spaces, suitable for housing the equipment; airborne noise produced based on the environment; possible flammability conditions.

FIMER will NOT be held liable for defects or malfunctions arising from: improper use of the equipment; deterioration resulting from transportation or particular environmental conditions; performing maintenance incorrectly or not at all; tampering or unsafe repairs; use or installation by unqualified persons.

FIMER is not responsible for any loss of the equipment, or part of it, which does not take place on the basis of the regulations and laws in force in the country of installation.

Scope and target audience

Purpose and document structure

This operating and maintenance manual is a useful guide that will enable you to work safely and carry out the operations necessary for keeping the equipment in good working order.



If the equipment is used in a manner not specified in this manual, the protections and the certifications provided by the equipment may be impaired with the consequent loss of warranty.



The language in which the document was originally written is ENGLISH; therefore, in the event of inconsistencies or doubts please ask the manufacturer for the original document.

List of appendix documents

In addition to this user manual and maintenance you can consult (and download) the product documentation by visiting www.fimer.com.



Part of the information given in this document is taken from the original supplier documents. This document contains only the information considered necessary for the use and routine maintenance of the equipment.

Operator and maintenance personnel skills/prerequisites



Personnel in charge of using and maintaining the equipment must be skilled for the described tasks and must reliably demonstrate their capacity to correctly interpret what is described in the manual.



For safety reasons, the installation must be performed by qualified installers and/or licensed electricians in accordance with the existing regulations in the country of installation and in accordance to all safety rules for performing electrical works. The installers must have demonstrated skills and knowledge of the inverter's structure and operation.



Inverter operation and maintenance by a person who is NOT qualified, is intoxicated, or on narcotics, is strictly forbidden.



The customer has civil liability for the qualification and mental or physical state of the personnel who interact with the equipment. They must always use the personal protective equipment (PPE) required by the laws of the country of destination and whatever is provided by their employer.

Application area, general conditions

FIMER shall not be liable for any damages whatsoever that may result from incorrect or careless operations.



*You may not use the equipment for a use that does not conform to that provided for in the field of use. The equipment **MUST NOT** be used by inexperienced staff, or even experienced staff if carrying out operations on the equipment that fail to comply with the indications in this manual and enclosed documentation.*

Intended or allowed use

This equipment is a inverter designed for:
transforming a continuous electrical current (DC)
supplied by a photovoltaic generator (PV)
in an alternating electrical current (AC)
suitable for feeding into the public distribution grid.

Limits in field of use

The inverter can be used only with photovoltaic modules which have ground isolated input poles.

Only a photovoltaic generator can be connected in the input of the inverter (do not connect batteries or other sources of power supply).

The inverter can be connected to the electricity grid only in countries for which it has been certified/approved.

The inverter cannot be connected to the DC side in parallel to other inverters.

The inverter may only be used in compliance with all its technical characteristics.

Improper or prohibited use



IT IS STRICTLY FORBIDDEN TO:

- Install the equipment in environments subject to particular conditions of flammability or in adverse or disallowed environmental conditions, (temperature and humidity).*
- Use the equipment with safety devices which are faulty or disabled.*
- Use the equipment or parts of the equipment by linking it to other machines or equipment, unless expressly provided for.*
- Modify operating parameters that are not accessible to the operator and/or parts of the equipment to vary its performance or change its isolation.*
- Clean with corrosive products that could corrode parts of the equipment or generate electrostatic charges.*
- Use or install the appliance or parts of it without having read and understood the contents of the user and maintenance manual.*
- Placing any heavy object, sit or stand up on the inverter.*
- Heat or dry rags and clothing on the parts in temperature. In addition to being hazardous, doing so would compromise component ventilation and cooling.*



General conditions

A description of the equipment characteristics is provided to identify its main components and specify the technical terminology used in the manual.

This chapter contains information about the models, details of the equipment, characteristics and technical data, overall dimensions and equipment identification.



The customer/Installer takes full responsibility if, when reading this manual, the chronological order of its presentation provided is not observed. All information is provided considering occasional inclusion of information in previous chapters.



In certain cases, there may be a need to separately document software functionality or attach supplementary documentation to this manual which is intended for more qualified professionals.

Identification of the equipment and manufacturer

The technical data provided in this manual does not substitute the data supplied on the labels affixed to the equipment.



The labels affixed to the equipment must NOT be removed, damaged, stained, hidden, etc., for any reason whatsoever.

ABB 1 Made in Italy

POWER MODULE (COMPONENT OF MODEL PVS-100-TL) [PROTECTIVE CLASS] 2 B 4 CE

MODEL: PVS-100-TL-POWER MOD

SOLAR INVERTER (COMPONENT OF MODEL PVS-100-TL) [PROTECTIVE CLASS] 4

MODEL: PVS-100-TL

V _{in} Operating Range	360-1000 V	V _{in} max	400 V 3Ø
V _{in} MPPT	480-850 V	P _{in} max (p=1)	100000 W
V _{in} max	1000 V	P _{in} max (p=3)	300000 W
I _{in} max	6 x 36 A	I _{in} max	100000 VA
I _{in} max	6 x 50 A	I _{in} max	50 / 60 Hz
		I _{in} max	145 A

-25 to +60 °C
-13 to +140 °F

ABB 1 Made in Italy

POWER MODULE (COMPONENT OF MODEL PVS-120-TL) [PROTECTIVE CLASS] 2 B 4 CE

MODEL: PVS-120-TL-POWER MOD

SOLAR INVERTER (COMPONENT OF MODEL PVS-120-TL) [PROTECTIVE CLASS] 4

MODEL: PVS-120-TL

V _{in} Operating Range	360-1000 V	V _{in} max	480 V 3Ø
V _{in} MPPT	570-850 V	P _{in} max (p=1)	120000 W
V _{in} max	1000 V	P _{in} max (p=3)	180000 W
I _{in} max	6 x 36 A	I _{in} max	120000 VA
I _{in} max	6 x 50 A	I _{in} max	50 / 60 Hz
		I _{in} max	145 A

-25 to +60 °C
-13 to +140 °F



ABB 1 Made in Italy [PROTECTIVE CLASS] 2 B 4 CE

WIRING BOX (COMPONENT OF MODEL PVS-100-TL) [PROTECTIVE CLASS] 2

MODEL: WB-SX-PVS-100-TL

-25 to +60 °C
-13 to +140 °F

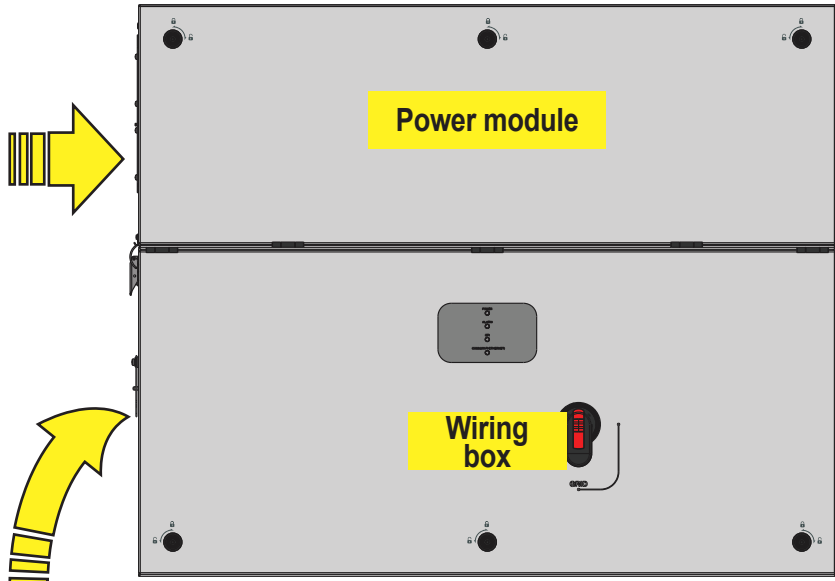
ABB 1 Made in Italy [PROTECTIVE CLASS] 2 B 4 CE

WIRING BOX (COMPONENT OF MODEL PVS-100-TL) [PROTECTIVE CLASS] 2

MODEL: WB-SX2-PVS-100-TL

-25 to +60 °C
-13 to +140 °F

ABB 1 Made in Italy [PROTECTIVE CLASS] 2 B 4 CE

WIRING BOX (COMPONENT OF MODEL PVS-120-TL) [PROTECTIVE CLASS] 2

MODEL: WB-SX-PVS-120-TL

-25 to +60 °C
-13 to +140 °F

ABB 1 Made in Italy [PROTECTIVE CLASS] 2 B 4 CE

WIRING BOX (COMPONENT OF MODEL PVS-120-TL) [PROTECTIVE CLASS] 2

MODEL: WB-SX2-PVS-120-TL

-25 to +60 °C
-13 to +140 °F

ABB 1 Made in Italy [PROTECTIVE CLASS] 2 B 4 CE

WIRING BOX (COMPONENT OF MODEL PVS-100-TL) [PROTECTIVE CLASS] 2

MODEL: WB-SY-PVS-100-TL

-25 to +60 °C
-13 to +140 °F

ABB 1 Made in Italy [PROTECTIVE CLASS] 2 B 4 CE

WIRING BOX (COMPONENT OF MODEL PVS-100-TL) [PROTECTIVE CLASS] 2

MODEL: WB-SY2-PVS-100-TL

-25 to +60 °C
-13 to +140 °F

ABB 1 Made in Italy [PROTECTIVE CLASS] 2 B 4 CE

WIRING BOX (COMPONENT OF MODEL PVS-120-TL) [PROTECTIVE CLASS] 2

MODEL: WB-SY-PVS-120-TL

-25 to +60 °C
-13 to +140 °F

ABB 1 Made in Italy [PROTECTIVE CLASS] 2 B 4 CE

WIRING BOX (COMPONENT OF MODEL PVS-120-TL) [PROTECTIVE CLASS] 2

MODEL: WB-SY2-PVS-120-TL

-25 to +60 °C
-13 to +140 °F

The regulatory label contains the following information:

1. Manufacturer
2. Model
3. Rating data
4. Certification marks

For connection to the network in South Africa.

According to NRS097-2-1 requirements, at the end of installation it is mandatory to apply the label at the left (supplied with the inverter) near the power module regulatory label.



WARNING!		
NRS 097-2-1:2017 (South Africa)		
Reference Impedance	Total [Ω]	X/R ratio
	0.156	3.9
Fault Level	I _{SC} [A]	S _{SC} [kVA] (three phase)
	1475	1018

It is not intended to connect this Inverter to a network with an higher Network Impedance.



Note: The labels are NOT to be hidden by foreign objects and parts (rags, boxes, equipment, etc.); they must be regularly cleaned and always kept in sight.

In addition to the label showing the inverter data, there are also additional identification labels for the power module and the wiring box.

The labels displays the following information:

MODEL NAME	• Power module or wiring box model
	• Power module or wiring box Part Number
P/N: P/P/P/P/P/P/P/P/P/P	• Power module/wiring box Serial Number
WO: XXXXXXXX	- YY = Year of manufacture
SO: SXXXXXXXXX Q1	- WW = Week of manufacture
SN: YYWWSSSSSS WK: WWYY	- SSSSSS = sequential number
	• Week/Year of manufacture



The officially required information is located on the regulatory label. The identification label is an accessory label which shows the information necessary for the identification and characterisation of the inverter by FIMER. In case you need to communicate with FIMER about the inverter, the information from identification label are mandatory.



The labels are NOT to be hidden by foreign objects and parts (rags, boxes, equipment, etc.); they must be regularly cleaned and always kept in sight.

An additional Communication Identification label is applied on the wiring box. The label displays the following information:

SN WLAN: SSSSSSSSSS	• WLAN board Serial Number
PN WLAN: VKA.V2P53.1	• WLAN board Part Number
Mac Address: AA:BB:CC:DD:EE:FF	• MAC address:
	- To be used to obtain the SSID of the wireless access point created by the inverter: ABB-XX-XX-XX-XX-XX-XX (where "X" is a hex digit of the MAC address).
	- To be used to obtain the "Host Name": http://ABB-XX-XX-XX-XX-XX-XX.local (where "X" is a hex digit of the MAC address).
	- MAC address it's the only required information to register the inverter with Aurora Vision.
SN WLAN: SSSSSSSSSS	• Inverter Serial Number
SN Wiring Box: ZZZZZZZZZZ	• Product Key:
MAC: AA:BB:CC:DD:EE:FF	To be used as wireless access point password, or to be used to access to the Web UI as username and password in case of lost credentials, and to commission inverter using FIMER Installer for Solar Inverters.
PK: 0000 - 0000 - 0000 - 0000	



The Communication Identification label is divided in two separate parts by a dashed line; take the bottom part and apply it on the plant documentation. (FIMER recommend to create a plant map and apply the Communication Identification label on it).

Models and range of equipment



The choice of the inverter model must be made by a qualified technician who knows about the installation conditions, the devices that will be installed outside the inverter and possible integration with an existing system.

“Wiring box” Model Number

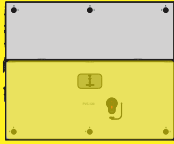

Description

WB-SX-PVS-100-TL WB-SX-PVS-120-TL	Input with 24 quick fit connectors pairs + String fuses (positive pole) + DC disconnect switches + AC and DC overvoltage surge arresters (Type II) + MPPT level input current monitoring (6 ch.)
WB-SX2-PVS-100-TL WB-SX2-PVS-120-TL	Input with 24 quick fit connectors pairs + String fuses (both positive and negative pole) + DC disconnect switches + AC disconnect switch + AC and DC overvoltage surge arresters (Type II) + individual string monitoring (24 string inputs)
WB-SY-PVS-100-TL WB-SY-PVS-120-TL	Input with 24 quick fit connectors pairs + String fuses (positive pole) + DC disconnect switches + AC and DC overvoltage surge arresters with replaceable cartridges (Type I+II for AC and Type I+II for DC) replaceable cartridges + MPPT level input current monitoring (6 ch.)
WB-SY2-PVS-100-TL WB-SY2-PVS-120-TL	Input with 24 quick fit connectors pairs + String fuses (both positive and negative pole) + DC disconnect switches + AC disconnect switch + AC and DC overvoltage surge arresters with replaceable cartridges (Type I+II for AC and Type I+II for DC) + individual string monitoring (24 string inputs)

“Power module” Model Number



Description

PVS-100-TL-POWER MODULE	Inverter section / power module with 100kW output power at 400Vac
PVS-120-TL-POWER MODULE	Inverter section / power module with 120kW output power at 480Vac

“Bracket” Model Number

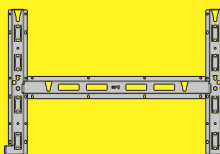

Description

PVS-100/120-TL-BRACKET	Bracket allowing both vertical and horizontal installation.
------------------------	---

List of main reference components

- | | | |
|---|--|--|
| 01 Power module | 13 Rear pins for bracket assembly | 50 DC interface connectors |
| 02 Wiring box | 14 Cover support brackets | 51 AC interface cables |
| 03 Mounting bracket | 15 DC disconnect switches | 52 Removable rear panels |
| 04 Handles | 16 DC input quick fit connectors | 53 DC overvoltage surge arresters board |
| 05 Cover quarter cam locks | 19 Positive string fuses plate | 54 Power module front cover |
| 06 Side latch | 20 Negative string fuses plate (-SX2, -SY2 only) | 55 Fan tray |
| 07 Wiring box front cover | 21 AC connection busbar | 56 Multi-core AC panel (opt.) |
| 08 LEDs panel | 22 AC overvoltage surge arresters | 57 RS-485&Rem.ON/OFF conn.(Service only) |
| 09 AC disconnect switch (-SX2, -SY2 only) | 25 Protective earth point (int.) | 58 AC interconnection board |
| 10 Protective earth point (ext.) | 27 AC protective shield | 59 DC interconnection board |
| 11 Single-core AC panel (default) | 28 Communication board | 60 DC protective shield |
| 12 Service cable glands | 30 Interface signal connectors | 61 Anti-condensation valve |

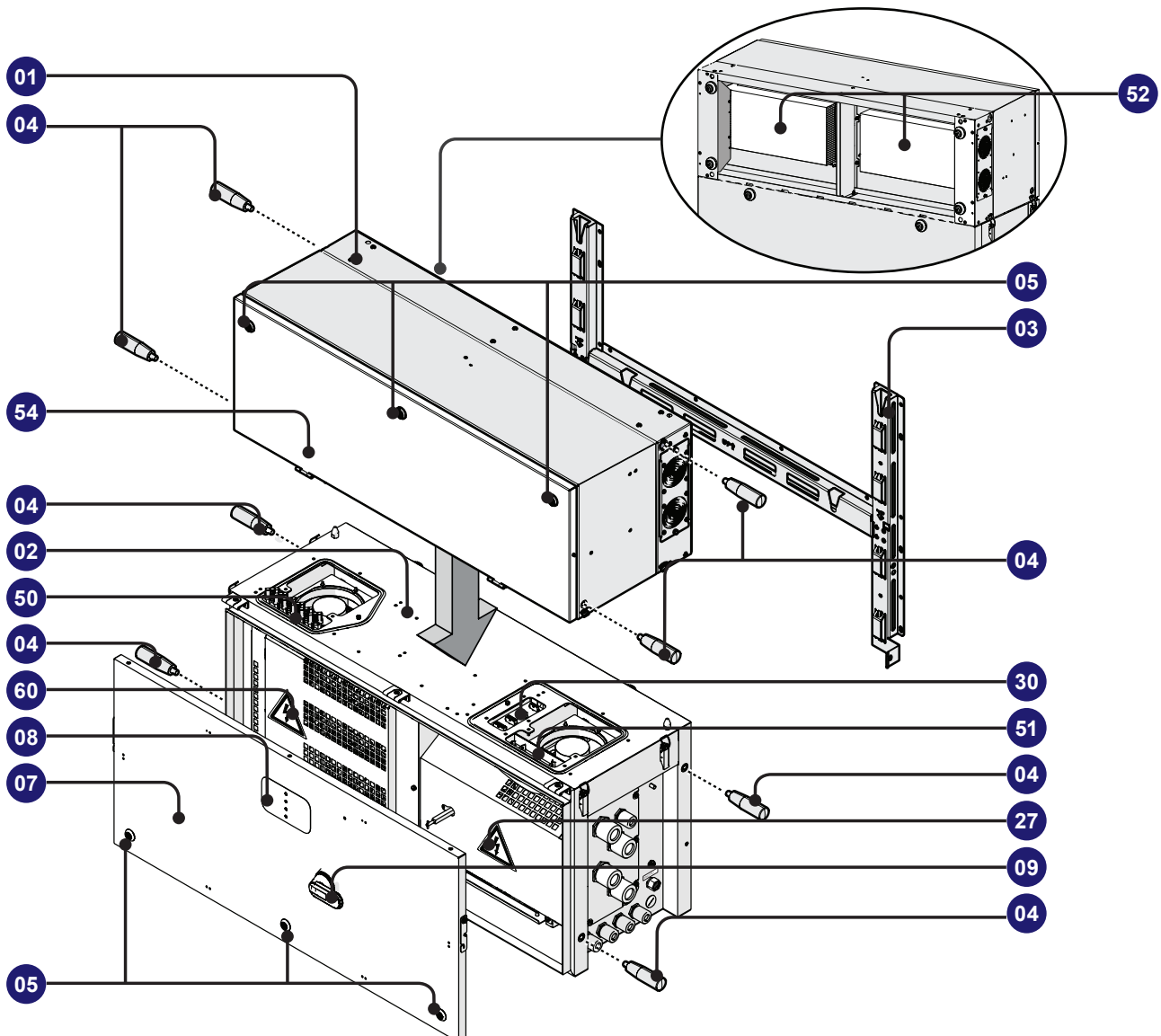

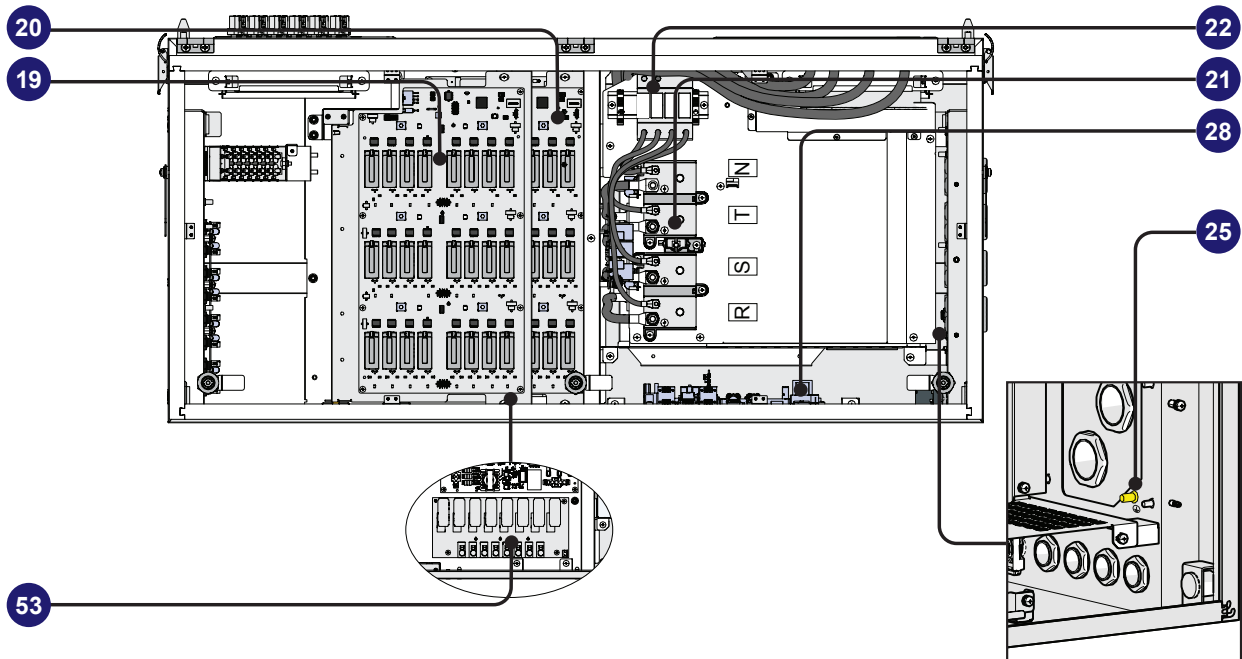
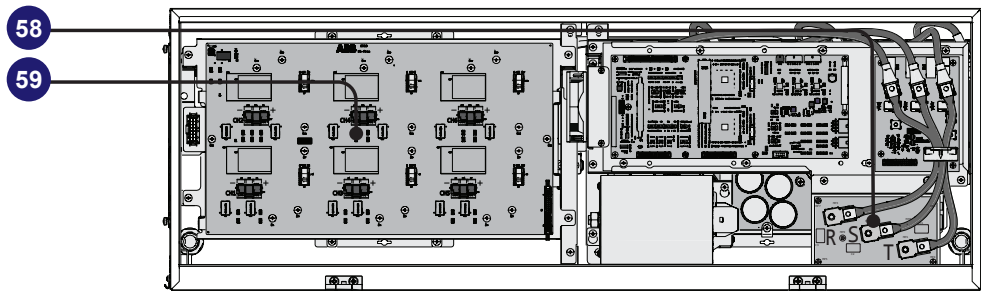
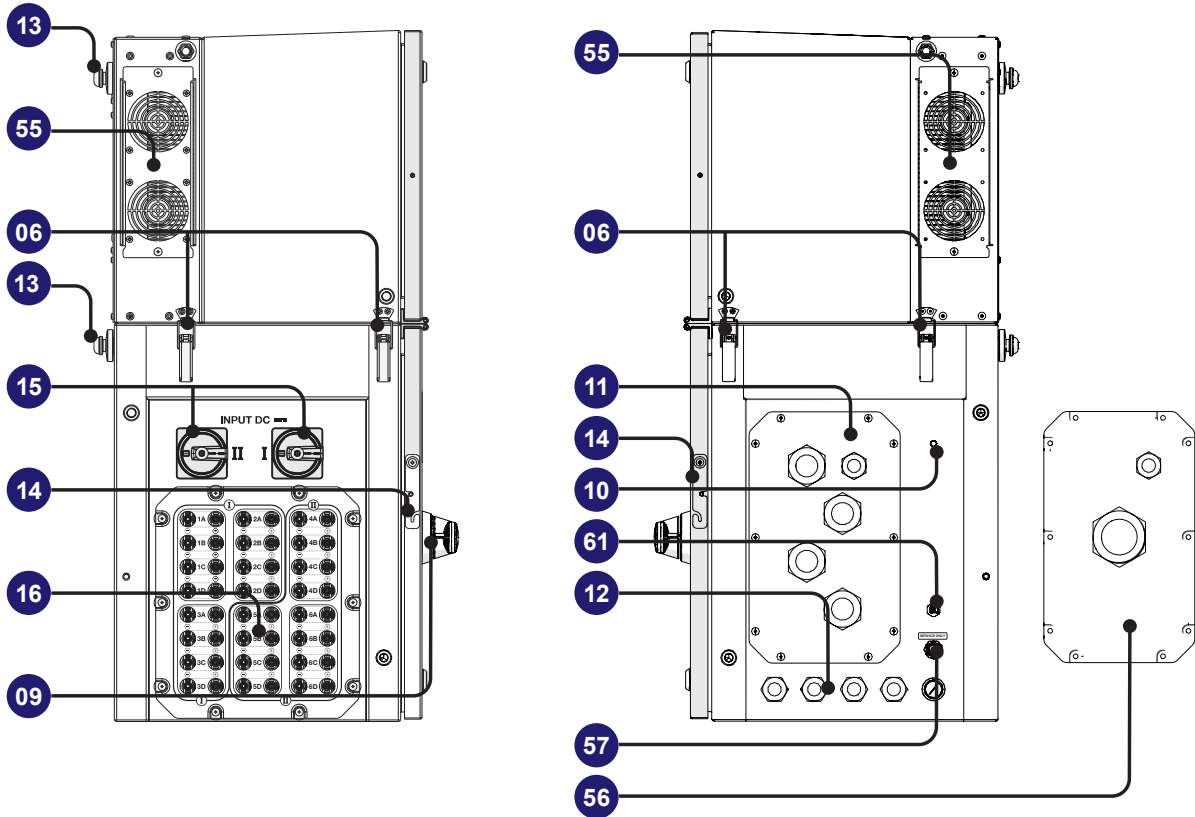

Communication board

- 33 Multifunction relay connector (ALARM)
- 34 RS-485 120Ohm resistance switch (service only)
- 35 RS-485 120Ohm resistance switch
- 36 RS-485 connector (RJ45) (Service only)
- 37 Remote ON/OFF terminal block
- 38 RS485 line terminal block
- 39 Ethernet connector 2 (RJ45)
- 40 Ethernet connector 1 (RJ45)
- 41 USB connector
- 42 SD card slot
- 43 CR2032 coin battery
- 44 RS485 line communication board
- 45 Memory board

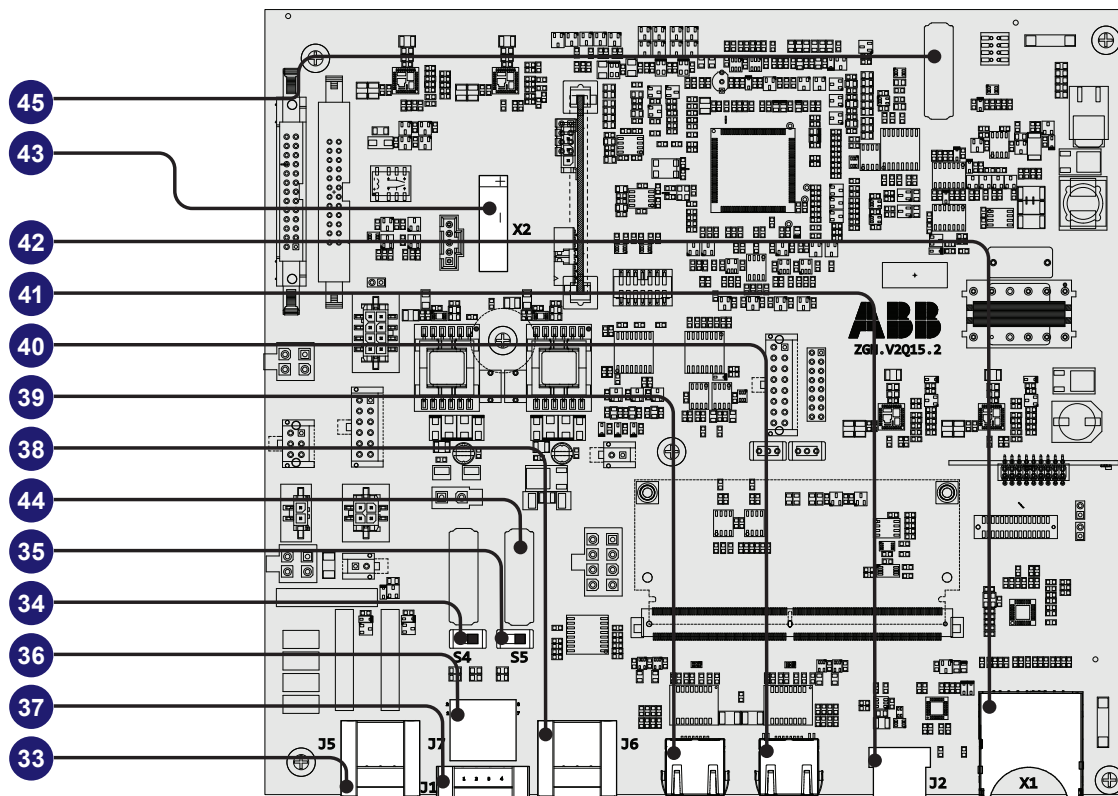

Characteristics and technical data

Table: Technical Data	PVS-100-TL	PVS-120-TL
Input side		
Absolute maximum DC input voltage (V _{max,abs})	1000 V	
Start-up DC input voltage (V _{start})	420 V (400 - 500 V)	
Operating DC input voltage range (V _{dcmín...V_{dcmáx}})	360 - 1000V	
Rated DC input voltage (V _{dcr})	620 Vdc	720 Vdc
Rated DC input power (P _{dcr})	102000 W	123000 W
Number of independent MPPT	6	
MPPT input DC voltage range at (V _{MPPTmín...V_{MPPTmáx}}) at P _{acr}	480 - 850 Vdc	570 - 850 Vdc
Maximum DC input power for each MPPT (P _{mppt,max})	17500 W [480V≤V _{MPPT} ≤850V]	20500 W [570V≤V _{MPPT} ≤850V]
Maximum DC input current for each MPPT (I _{dcmáx})	36 A	
Maximum input short circuit current (I _{scmáx}) for each MPPT	50 A ⁽¹⁾	
Maximum return current (AC side vs DC side)	Negligible in normal operating conditions ⁽⁶⁾	
Number of DC input connection pairs for each MPPT	4	
DC connection type	PV quick fit connector ⁽²⁾	
Type of photovoltaic panels that can be connected at input according to IEC 61730	Class A	
Input protection		
Reverse polarity protection	Yes, from current limited source	
Input over voltage protection for each MPPT - replaceable surge arrester board	Type II with monitoring only for SX and SX2 versions; Type I+II with monitoring only for SY and SY2 versions	
Photovoltaic array isolation control	as per IEC62109	
DC switch rating for each MPPT	50 A / 1000 V	
Fuse rating (versions with fuses)	15 A (gPV/1000 Vdc) ⁽³⁾	
String current monitoring	SX2, SY2: (24 input string) Individual string current monitoring; SX, SY: (6ch) Input current monitoring per MPPT	
Output side		
AC grid connection type	Three phase 3W+PE or 4W+PE	
Rated AC power (P _{acr @cosφ=1})	100 000 W	120 000 W
Maximum AC Output Power (P _{acmáx @cosφ=1})	100 000 W	120 000 W
Maximum apparent power (S _{máx})	100 000 VA	120 000 VA
Rated AC grid voltage (V _{ac,r})	400 V	480 V
AC voltage range	320...480 V ⁽⁴⁾	384...576 V ⁽⁴⁾
Maximum AC output current (I _{ac,max})	145 A	
Contributory fault current	155 A	
Inrush current	Negligible	
Rated Output Frequency (f _r)	50 Hz / 60 Hz	
Output Frequency Range (f _{mín...f_{máx}})	45...55 Hz / 55...65 Hz ⁽⁵⁾	
Nominal power factor and adjustable range	> 0.995, adj. ± 0 - 1 (over/under excited)	
Total current harmonic distortion	<3%	
Maximum AC cable	185 mm ² copper/aluminum	
AC Connections Type	Provided bar for lug connections M10, single core cable glands 4xM40 and M25, multi core cable gland M63 as option	
Output protection		
Anti-islanding Protection	Active frequency drift combined with RoCoF techniques as per IEC 62116	
Maximum external AC overcurrent protection	225 A	
Output overvoltage protection - Modular surge arresters	Type 2 with monitoring	
Operating performance		
Maximum Efficiency (η _{máx})	98.4%	98.9%
Weighted Efficiency (EURO)	98.2%	98.6%

Table: Technical Data		PVS-100-TL	PVS-120-TL
Communication			
Embedded communication interfaces		1x RS485, 2x Ethernet (RJ45), WLAN (IEEE802.11 b/g/n @ 2,4 GHz)	
User Interface		4 LEDs, Web User Interface, Mobile APP	
Communication protocol		Modbus RTU/TCP (Sunspec compliant)	
Commissioning tool		Web User Interface, Mobile APP/APP for plant level	
Remote monitoring services		Aurora Vision® monitoring portal	
Advanced features		Embedded logging, direct telemetry data transferring to FIMER cloud	
Environmental			
Ambient temperature range		-25...+60°C / -13...140°F with derating above 40°C / 104 °F	
Storage temperature		-40°C...+85°C / -40°F...185°F	
Relative Humidity		4...100 % with condensation	
Sound pressure level, typical		68 dB(A) @ 1 m	
Maximum operating altitude without derating		2000 m / 6560 ft	
Environmental pollution degree classification for external environments		3	
Environmental class		Outdoor	
Climatic category according to IEC 60721-3-4		4K4H	
Physical			
Environmental Protection Rating		IP 66 (IP54 for the cooling section)	
Cooling		Forced air	
Dimensions (H x W x D)		867x1086x419 mm / 34.2" x 42.8" x 16.5" for -SX, -SY model 867x1086x458 mm / 34.2"x42.8"x18.0" for -SX2, SY2 model	
Weight		70kg / 154 lbs for power module ; ~55kg / 121 lbs for Wiring box Overall max ~125 kg / 276 lbs	
Mounting system		Mounting bracket vertical & horizontal support	
Overvoltage rating as per IEC 62109-1		II (DC input) III (AC output)	
Safety			
Safety class		I	
Insulation Level		Transformerless	
Marking & EMC		CE ⁽⁷⁾ conformity according to LV and EMC directives	
Safety		IEC/EN 62109-1, IEC/EN 62109-2	
Grid standard (check your sales channel for availability)		CEI 0-16, CEI 0-21, IEC 61727, IEC 62116, IEC 60068, IEC 61683, JORDAN IRR-DCC-MV, AS/NZS4777.2, VDE-AR-N 4105, VDE V 0-126-1-1, VFR 2014, Belg C10-C11, UK59/3, P.O. 12.3, ITC-BT-40, EN50438 Generic +Ireland, CLC-TS 50549-1/2	
Accessories			
Assembly accessories		- PVS Installation Kit - AC multicore cable gland plate (Supports M63 Ø 37...53mm + M25 Ø 10...17mm)	

- Maximum number of opening 5 under overloading
- Please refer to the document "String inverters – Product manual appendix" available at www.fimer.com for information on the quick-fit connector brand and model used in the inverter
- Maximum fuse size supported 20A. Additionally two strings input per MPPT supports 30A fuse size for connecting two strings per input.
- The AC voltage range may vary depending on specific country grid standard
- Frequency range may vary depending on specific country grid standard
- In the event of a fault, limited by the external protection envisaged on the AC circuit
- Hereby, Power-One Italy S.p.A. (A Member of the FIMER Group) declares that the radio equipments (radio module combined with the inverter), to which this user manual refers, are in compliance with the Directive 2014/53/EU. The full text of the EU Declaration of Conformity is available at the following internet address: www.fimer.com

Remark. Features not specifically listed in the present data sheet are not included in the product

Tightening torques

To maintain the IP66 protection of the system and for optimal installation, the following tightening torques must be used:

Tightening torques	
Single core AC cable gland ¹¹ M40	8.0 Nm
PE cable gland M25	7.5 Nm
Multi core AC cable gland ⁵⁶ M63	18 Nm
Service cable gland ¹² M25	7.5 Nm
AC connection busbar ²¹ bolts	25 Nm
AC interface cables	4.0 Nm
PE interface cable	2.0 Nm
Protective earth point (int.) ²⁵ nut	21 Nm
Protective earth point (ext.) ¹⁰ nut	12 Nm
Junction Screws	10 Nm
Side bracket screws	5 Nm

Cable gland clamping range

Cable gland clamping range	
Single core AC cable gland ¹¹ M40	19...28mm
PE cable gland M25	10...17mm
Multi core AC cable gland ⁵⁶ M63	37...53mm
Service cable gland ¹² M25	10...17mm

Overall dimensions

The overall dimensions (not including the mounting bracket) are expressed in millimetres.

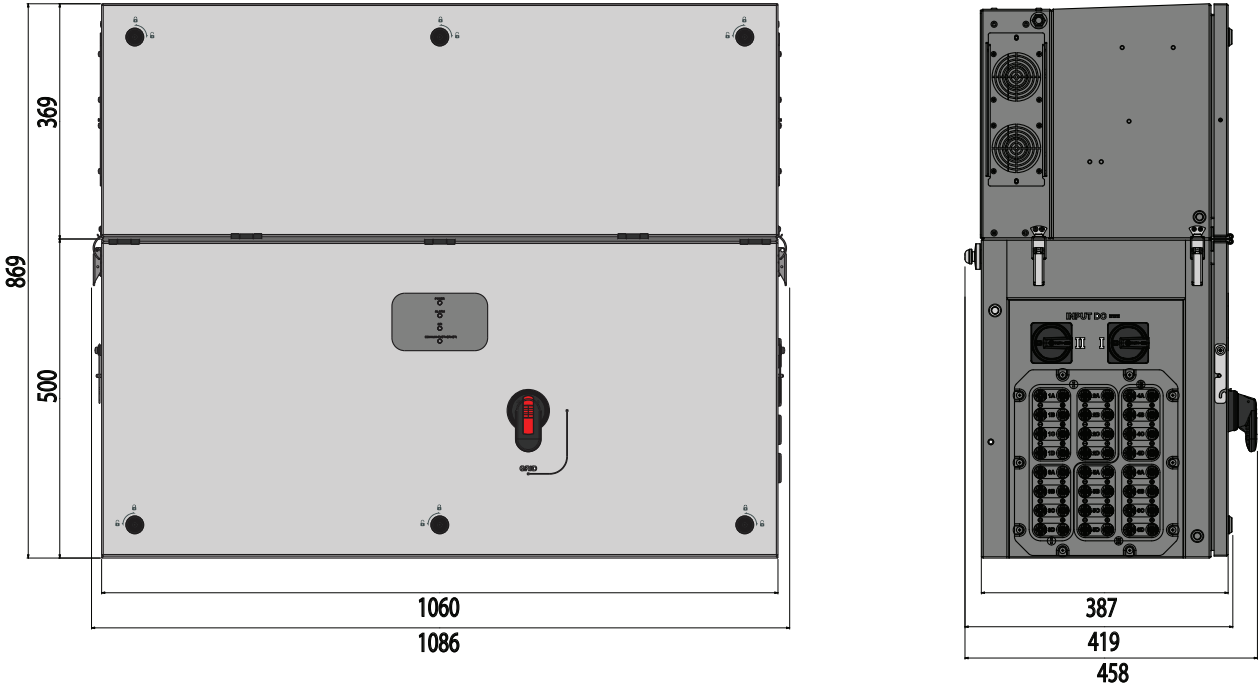

Mounting bracket.

The dimensions of the wall mounting bracket are expressed in millimetres. The diameter of holes in the bracket are 9mm.

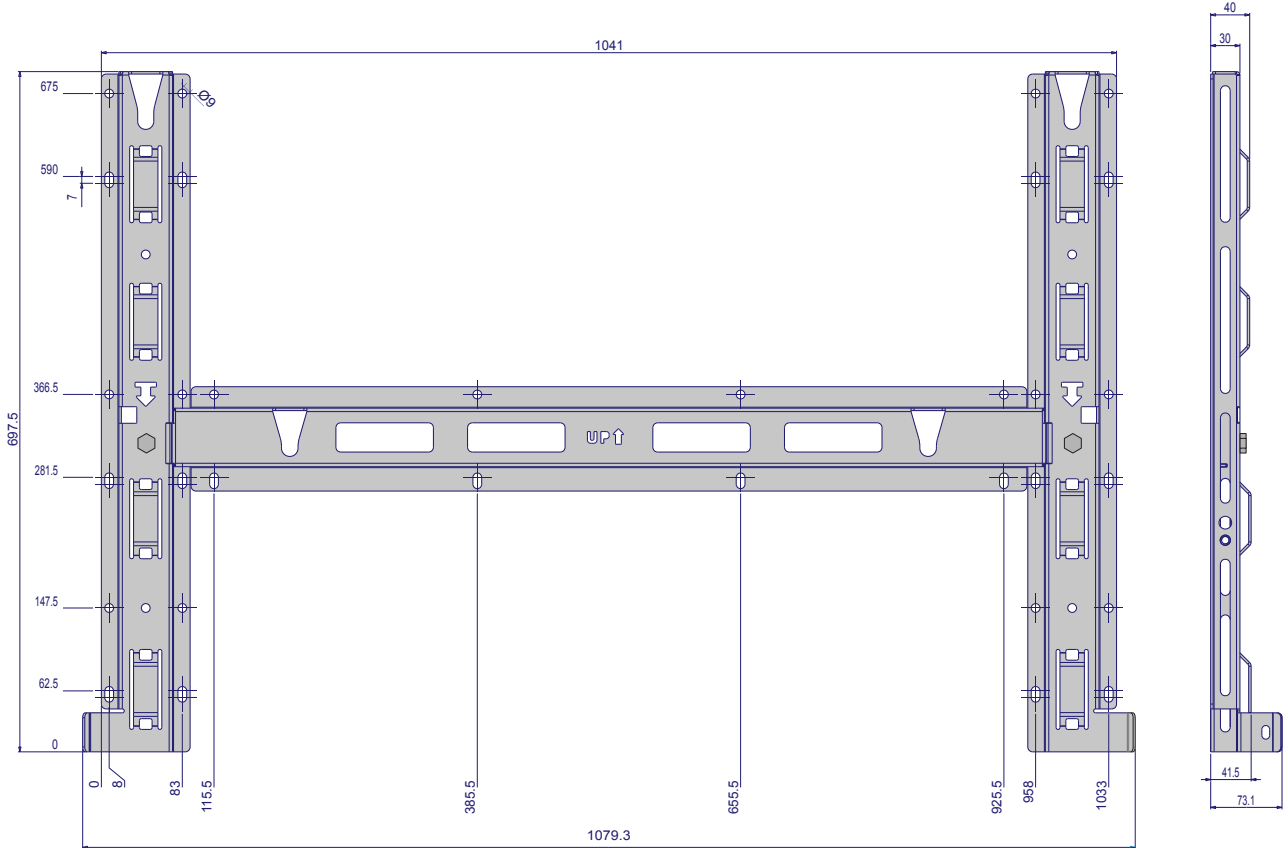

000959AG-F

Efficiency curves

The equipment was designed considering current energy conservation standards, to avoid waste and unnecessary leakage.

Graphs of the efficiency curves of all models of inverter described in this manual are shown below.

The efficiency curves are linked to technical parameters that are continually being developed and improved and should therefore be considered approximate.

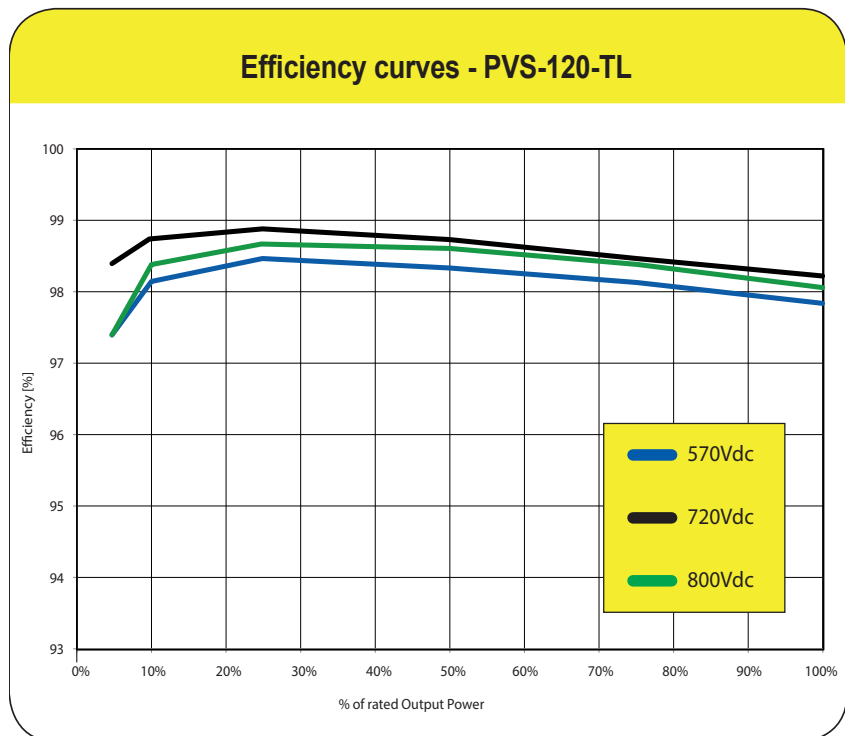
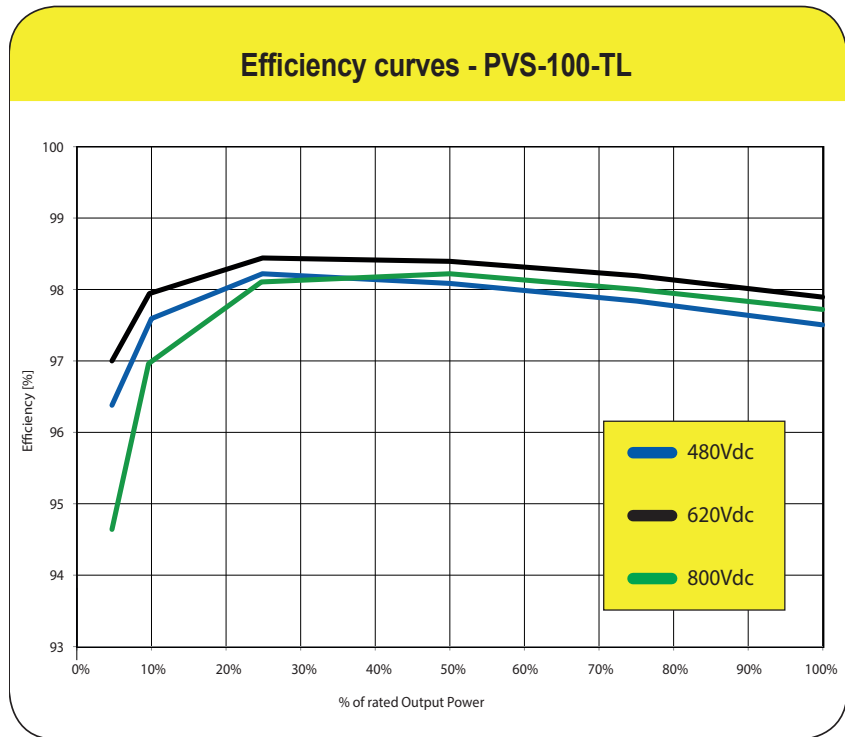

Power limitation (Power derating)

In order to allow inverter operation in safe thermal and electrical conditions, the unit automatically reduces the value of the power fed into the grid.

Power limiting may occur due to:

- Adverse environmental conditions (thermal derating)
- Percentage of output power (value set by the user)
- Grid voltage over frequency (mode set by user)
- Grid overvoltage $U > 10\text{min Der.}$ (enabling carried out by user)
- Anti-islanding
- Grid under voltage
- Input voltage values too high.
- High input current values.

Power reduction due to environmental conditions

The power reduction value and the inverter temperature at which it occurs depend on the ambient temperature and on many operating parameters.

Example: input voltage, grid voltage and power available from the photovoltaic field.

The inverter can therefore reduce the power during certain periods of the day according to the value of these parameters.

In any case, the inverter guarantees the maximum output power even at high temperatures, provided the sun is not shining directly on it.

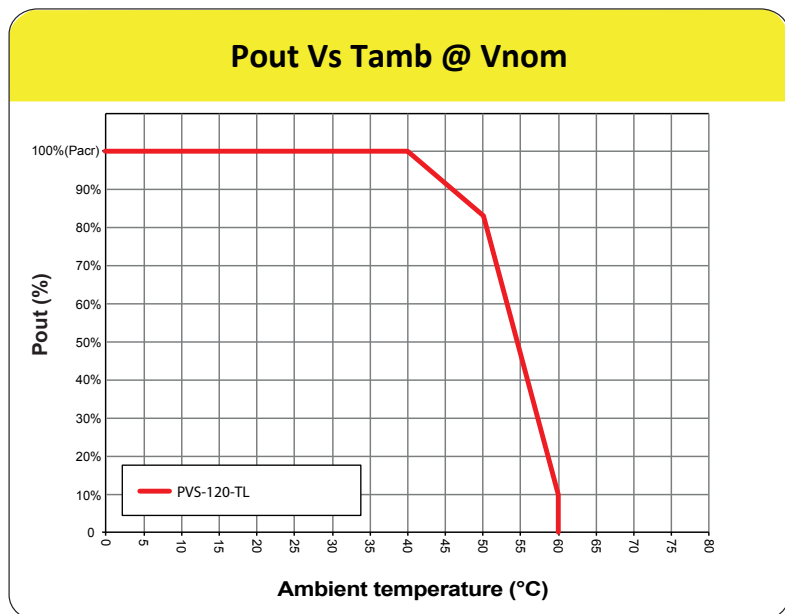
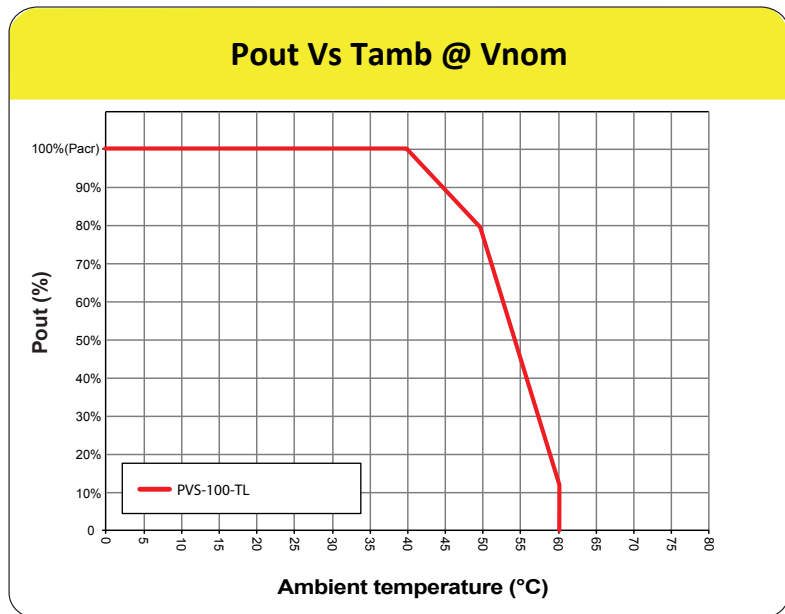

Power reduction due to the input voltage

The reduction of the power supplied where the DC input voltage values are too high or too low is adjusted automatically.

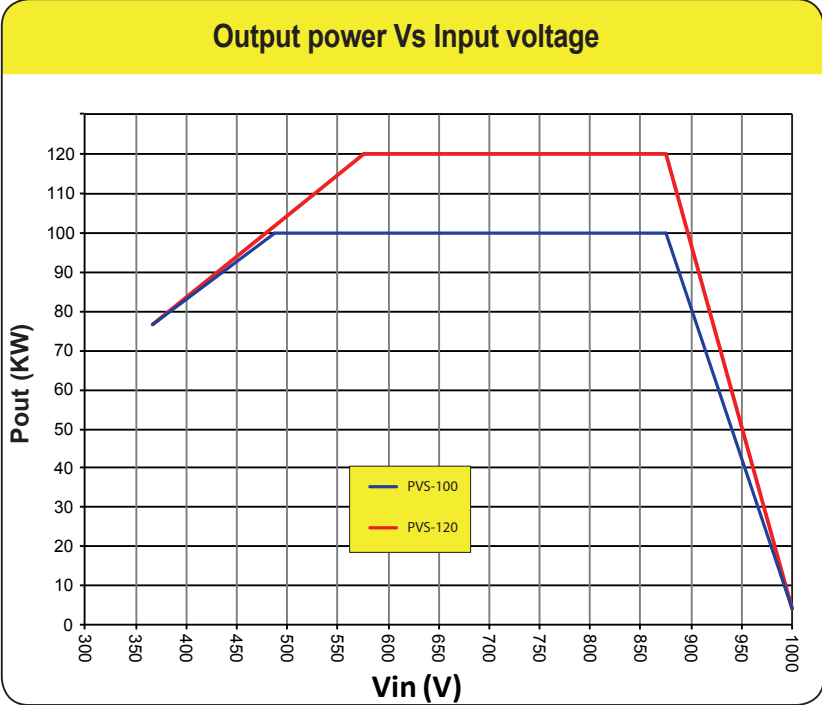

P- Q curve capability

Based on the standard network on the country the capability of P-Q curve can be reduced.

	Test conditions	
	PVS-100-TL	PVS-120-TL
Ambient temperature	*40 °C	
Rated output voltage (Un)	400 Vac	480 Vac
Rated active power (Pn)	100 kW	120 kW
Nominal apparent power (Sn)	100 kVA	120 kVA
Rated reactive power (Qn)	100 kVAR	120 kVAR
Cosphi	-0 ... 1 ... 0 +	
Capability with grid voltage	1.0xUn	

*Thermal derating could be occurred if input voltage is over 800V.

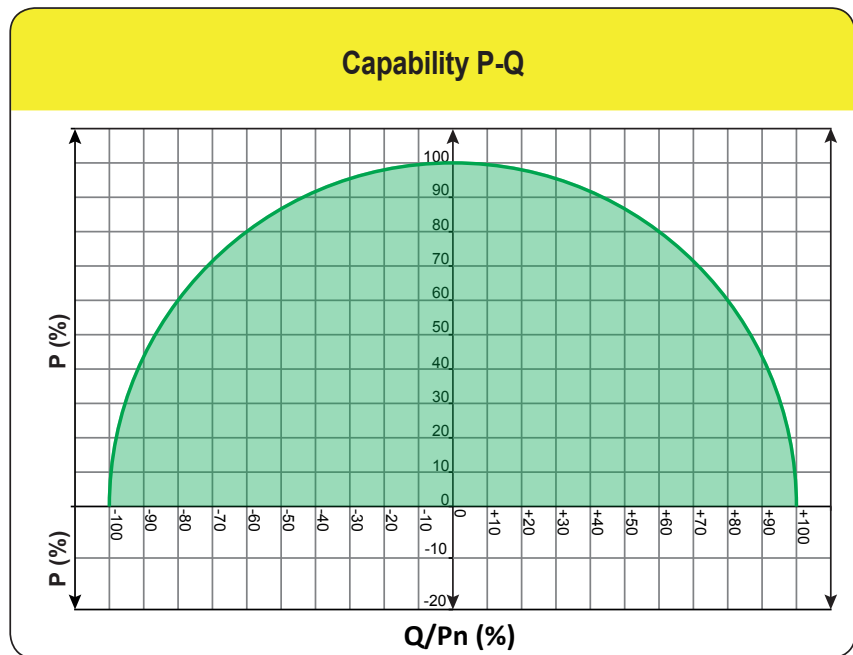

Characteristics of a photovoltaic generator

A PV electric system consists of an assembly of photovoltaic modules that transform solar radiation into DC electrical energy and can be made up of:

Strings: number of PV modules connected in series

Array: group of strings connected in parallel

Strings and arrays

The string technology was developed to significantly reduce the installation costs of a photovoltaic system, mainly associated to wiring on the DC side of the inverter and subsequent distribution on the AC side. A photovoltaic module consists of many photovoltaic cells mounted on the same support.

- A string consists of a certain number of module connected in series.
- An array consists of two or more strings connected in parallel.

Large photovoltaic systems can include multiple arrays connected to one or more inverters.

The greater the number of panels in each string, the lower the cost and the less complex the wiring connections of the system.

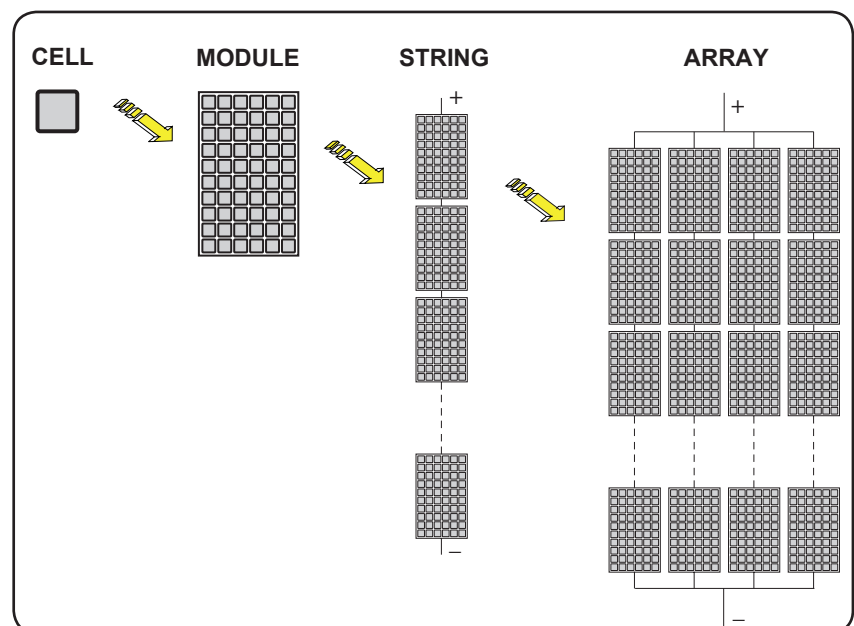

Description of the equipment

This equipment is a string inverter which converts the direct current of a photovoltaic generator into alternating current and feeds it into the public distribution grid.

Photovoltaic panels convert solar radiation into “DC” electrical energy (via a photovoltaic field, also called PV generator); in order to use it, it is transformed into “AC” alternate current. This conversion, known as inversion from DC to AC, is done in an efficient way by the FIMER inverters, without using any rotary elements, rather only via static electronic systems.

In order to allow inverter operation in safe thermal and electrical conditions, the unit automatically reduces the value of the power fed into the grid under adverse environmental conditions or unsuitable input voltage values.

When connected in parallel with the grid, the alternating current from the inverter flows directly into the domestic or industrial distribution circuit, which is in turn connected to the public distribution grid.

This way the solar energy system compensates for the energy drawn from the utilities connected to the grid to which it is linked.

When the photovoltaic system is not generating sufficient energy, the power required to ensure proper operation of connected loads is taken from the public distribution grid. While if too much energy is produced, it is directly fed to the grid, thus becoming available to other users.

According to national and local standards and regulations the produced energy can be sold to the grid or credited to the user against future consumption, thus granting a great saving of money.

Operating diagram (example)

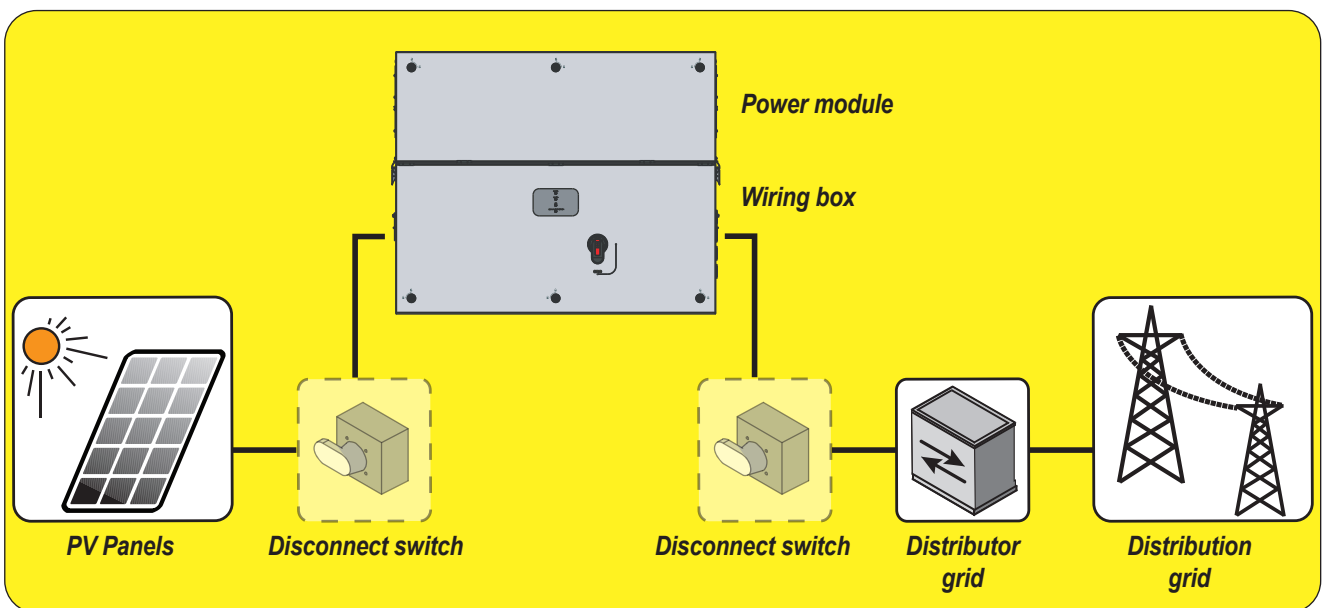

Mutual connection of multiple inverters

If the photovoltaic system exceeds the capacity of a single inverter, it is possible to connect multiple inverters to the system, each of them in turn connected on the DC side to an appropriate section of the photovoltaic generator, and on the AC side to the distribution grid.

Each string inverter will work independently of the others and its own photovoltaic module will supply the maximum power available to the grid.

Notes on the system sizing

Decisions on how to structure a photovoltaic system depend on a series of factors and considerations, such as the type of panels, the space availability, the future location of the system, energy production goals over the long term, etc.

A configuration program that can help to correctly size the photovoltaic system is available on the FIMER website (<http://stringsizer.fimer.com>).

Functionality and components of the equipment

Highlights

- 6 independent MPPT
- Two box configuration, separate power module and wiring box
- Transformerless inverter
- Maximum efficiency up to 98.9%.
- Double stage topology for a wide input range
- Large set of specific grid codes available which can be selected directly in the field
- Both vertical and horizontal installation
- 2 available sizes, 100 and 120 kW with 400 and 480 Vac of output voltage, respectively
- Wireless access to embedded user interfaces
- FIMER Installer for Solar Inverters APP for commissioning of inverters
- Ethernet daisy chain enabled (supports both ethernet star/ring topology)
- One RS485 line acting as master or slave
- Modbus TPC/RTU Sunspec compliant
- Support to FIMER accessories directly connected to the inverter via RS485
- Remote monitoring and firmware update via Aurora Vision® (logger free)

Improved commissioning and maintenance

FIMER Installer for Solar Inverters APP

Improved multi inverter installation with FIMER Installer for Solar Inverters APP by using Android mobile devices (the app for iOS mobile devices will be implemented soon).

Integrated Web User Interface

The inverter is equipped with an ethernet and wireless (IEEE802.11 b/g/n) board and with an Integrated Web User Interface that allow a full access to all main configuration and parameters of the inverter. It can be accessed by using from any ethernet or wireless capable device like laptop, tablet or smartphone via a common internet browser.

Remote firmware update function

The inverter firmware can be updated remotely using the Integrated Web User Interface dedicated section or via Aurora Vision® or via FIMER Installer for Solar Inverters APP.

Aurora Vision® Plant Management Platform

Integrated logging capability allows remote monitoring of the plant without the need of any additional external loggers.

Aurora Vision is a cloud based platform enabling remote monitoring and asset management of FIMER devices in range of solar power application.

Aurora Vision consists of a three different product:

1. **Plant Portfolio Manager** is a full featured web based application used by solar power professionals to monitor and manage a portfolio of solar power plants using FIMER inverters.
2. **Plant Viewer** is an easy to use web based serviced application used by non-solar power professionals (such as homeowners or small business owners) to monitor solar power plants they own.
3. **Plant Viewer for Mobile** is the mobile version of **Plant Viewer** enabling non-solar power professionals to remotely monitor their own PV plants by using smart phones, tablets and iPod Touch with IOS and Android operating systems.

All three product previously mentioned work together to allow solar power professional and site owners to collaboratively manage solar power plant.

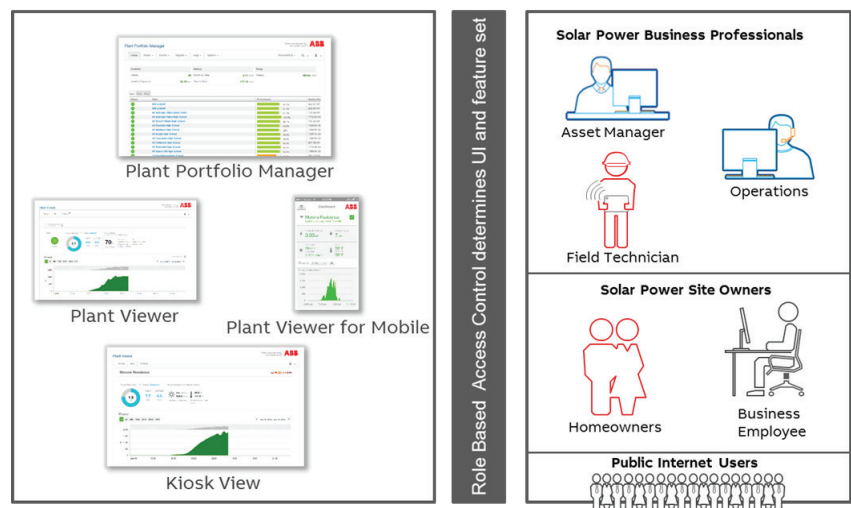

Please contact the FIMER technical support for getting your own plant portfolio manager account (mainly for installers and plant administrators). Please get your Plant Viewer and Plant Viewer for Mobile by accessing the website www.auroravision.net and click on "Register with Plant Viewer" button (mainly for site owners).

Configurable relays

This functionality is not available yet. It will be implemented soon.

Remote switch-on/switch-off

This command can be used to switch off/switch on the inverter via an external (remote) command.

This functionality must be enabled in the web user interface and when active, switching on the inverter, besides being dictated by the presence of normal parameters which allow the inverter to be connected to the grid, also depends on the external control for switching on/off.

Reactive power feed into the grid

The inverter is able to produce reactive power and can feed this power into the grid via the power factor setting.

Power feeding modes vary according to the country of installation and the grid companies.

Limiting the active power fed into the grid

The inverter can limit the amount of active power fed into the grid by the inverter to the desired and settable value.

Overvoltage surge arrester monitoring

The inverter monitors the status of the overvoltage surge arresters, and generates a warning in the event of a fault (viewable via monitoring system, internal web user interface or Installer Mobile APP).

Data transmission and control

Embedded multi communication interfaces (WLAN, Ethernet, RS485) combined with a Sunspec compliant Modbus protocol (RTU/TCP) allow the inverter to be easily integrated with any third party monitoring and-control systems that support the same Sunspec standard.



Please contact the FIMER technical support or get access to Sunspec alliance website for further information on Modbus Sunspec products.

Communication connection diagrams

The communication connection diagrams shows how the integrated ethernet and wireless board allows the locally or remotely connection to the inverter.

Communication interface

The inverter provide the following integrated communication interfaces:

- Wireless channel (IEEE 802.11 b/g/n@2.4GHz)

The use is recommended to access wirelessly to embedded web server by using any WLAN standard device (PC, tablet, smartphone) for commissioning and parameter setting. Additionally there is second radio channel that can be used for connection to wireless router.

- 2x Ethernet ports (10/100BaseTx - RJ45 plugs)

The ports are configured by default for enabling daisy chain connection of the inverters over the Ethernet bus.

In order to improve the reliability of the communication with the inverters it is also allowed to create ring shape layout by using this Ethernet bus

- 1x RS485 ports (terminal block)

The port enables daisy chain connection of the inverters over the serial line (slave mode). The port can either be used for connecting supported accessories (like weather station, meter...): in this case data from accessories will be logged and transferred to the cloud by inverter itself (master mode).

Ethernet bus connection

By default the 2 Ethernet ports of the inverters are already configured for enabling communication over daisy chain layout.

Once physically connected the inverters does not need specific settings: after the first turning on, the inverters automatically got all needed network parameters with or without the presence of DHCP server. If an internet connection is available on site the inverters are automatically configured to transmit telemetry data to Aurora Vision Cloud without the need of installing any additional devices (logging capability are already integrated into the inverter by default).



Aurora Vision Plant Management platform is the FIMER cloud solution allowing customer to remotely monitor and manage its own solar plants. Please refer to <http://www.fimer.com> or contact FIMER technical support for further information on how getting an Aurora Vision account

With the inverters connected over Ethernet daisy chain and with an available internet connection it will be always possible, via Aurora Vision Cloud, to upgrade remotely the firmware of the inverters.

In order to improve the communication services and allow reaching of all the inverters in the chain also in presence of fault it is recommended to create a ring shape layout by connecting both the first and the last inverters of the chain to the local Ethernet switch (as shown in the picture)

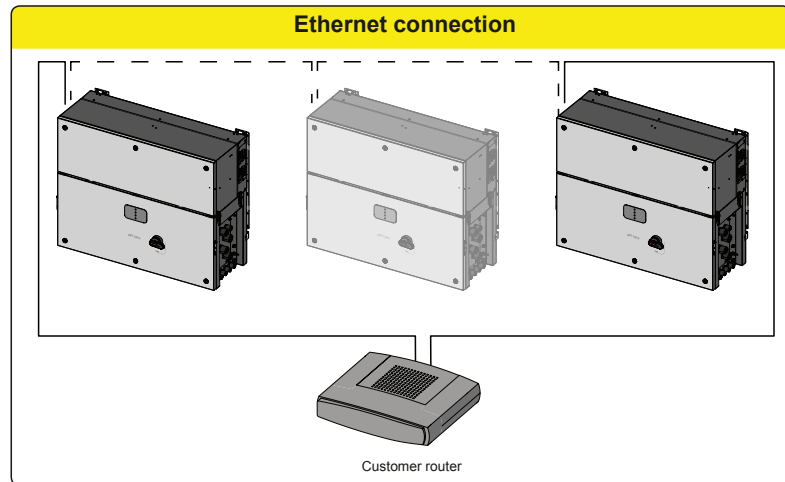

Please refer to chapter 5 for further information about the installation.

Topographic diagram of the equipment

The diagram summarises the internal structure of the inverter.

The internal circuitry is with double stage conversion and therefore consists of:

- DC/DC input converter (booster)
- DC-AC output inverter

The DC-DC converter and the DC-AC inverter both work at a high switching frequency and are therefore small and relatively light related to output power.

The input converter is dedicated to multiple PV arrays with a maximum power point tracking (MPPT) function in order to maximize the exportation of energy from the photovoltaic generator.

This inverter version is of the type without transformer, that is without galvanic insulation between the input and the output. This allows ultimately an increase in conversion efficiency. The inverter is already equipped with all the protections necessary for safe operation and compliance with the norms, even without the insulating transformer.

The operation and the protection management of the inverter is controlled by two independent DSPs (Digital Signal Processors) and a central microprocessor.

A dedicate microprocessor is used for user communication interfaces.

The connection to the distribution grid is thus kept under control by two independent DSPs, in full compliance with the electric field norms both for power supply to the systems as well as security.

The operating system carries out the task of communicating with its components in order to carry out data analysis.

In doing all this, we guarantee optimal operation of the whole assembly and a high performance in all irradiation conditions and always ensuring full compliance with the relevant directives, standards and regulations.

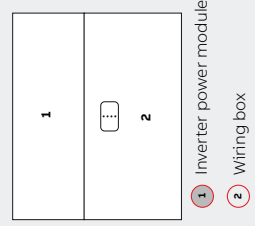
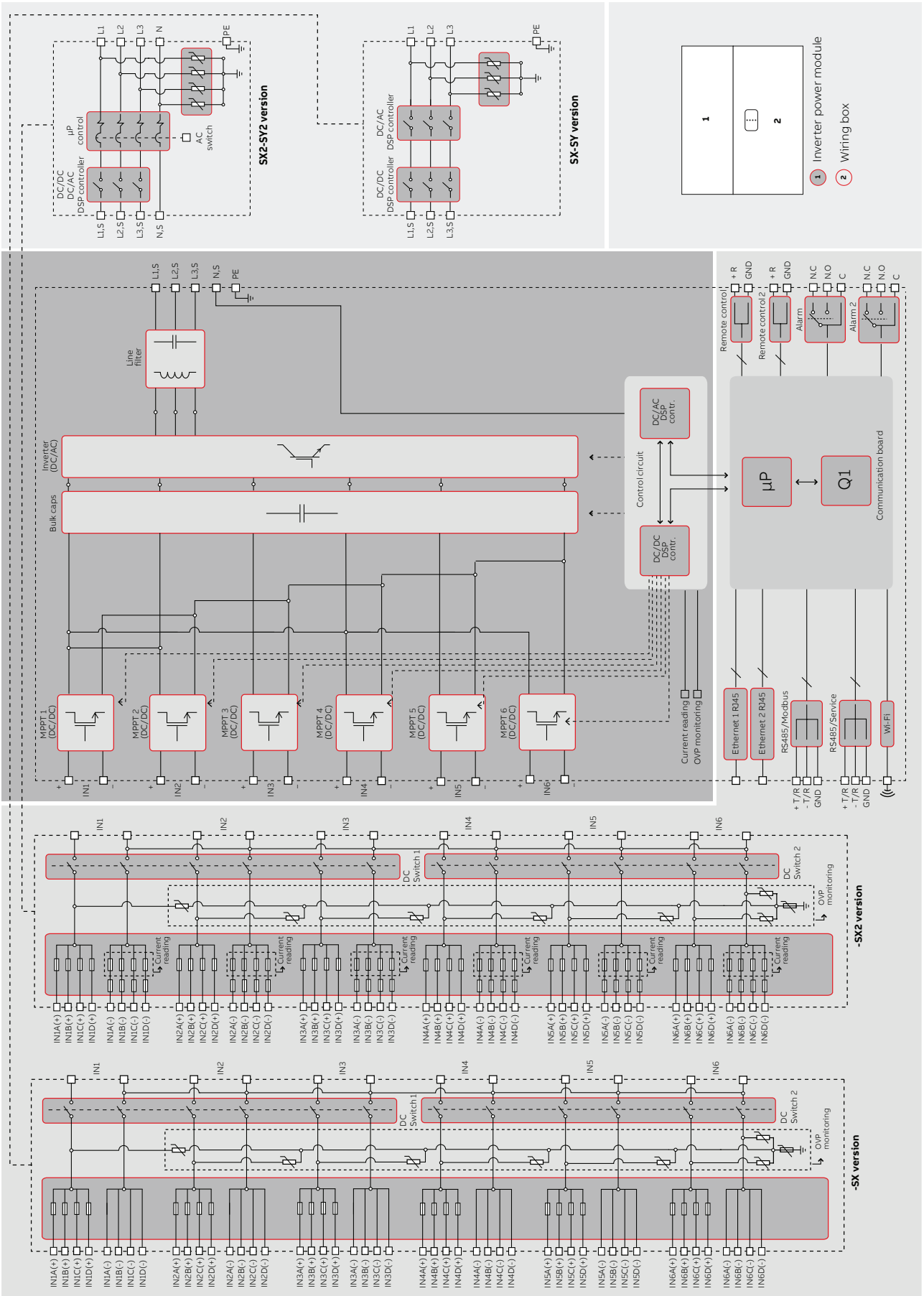

Safety devices

Anti-Islanding

In the event of a local grid outage by the electricity company, or when the equipment is switched off for maintenance operations, the inverter must be physically disconnected to ensure the protection of the people working on the grid, in accordance with the relevant national laws and regulations. To prevent possible islanding, the inverter is equipped with an automatic safety disconnection system called "Anti-Islanding".

The method used to ensure an active anti-islanding protection is: active frequency drift in combination with techniques RoCoF

Anti-islanding protection mechanisms are different depending on the grid standards, even if they all have the same purpose.

Ground fault of the photovoltaic panels

Use this inverter with panels connected in "floating" mode, i.e. with no earth connections on the positive and negative terminals. An advanced ground fault protection circuit continuously monitors the ground connection and disconnects the inverter when a ground fault indicating the fault condition by means of the red "GFI" LED on the LED panel on the front side.

String fuses

String fuses are available inside the wiring box (in the -SX, -SY wiring box version only on positive input side [19](#); in the -SX2, -SY2 wiring box version on both positive [19](#) and negative [20](#) input side) and protect the appliance from currents exceeding the limit value independently for each string.



The sizing of the fuses must therefore be carefully assessed during installation. Refer to the "Sizing of fuses" chapter of this manual to know how to choose the proper size of fuses.

Overvoltage surge arresters

As an additional protection to prevent damage caused by the discharges from lightning and electrostatic induction phenomena, the wiring box is equipped with DC overvoltage surge arresters [32](#) and with AC overvoltage surge arresters [22](#).

Other safeguards

The inverter is equipped with additional protective devices to ensure safe operation in any circumstance. These protections include:

- Constant monitoring of the grid voltage to ensure that voltage and frequency values remain within operating limits;
- Internal temperature control to automatically limit the power if necessary to prevent overheating of the unit (derating).

The numerous control systems determine a redundant structure to ensure absolutely safe operations.

General conditions

Some recommendation apply only to large size product or multiple small size product packaging.

Transport and handling

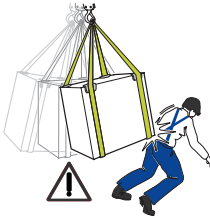

Lifting

Transport of the equipment, especially by road, must be carried out with means for protecting the components (in particular, the electronic components) from violent shocks, humidity, vibration, etc.

During handling, do not make any sudden or fast movements that can create dangerous swinging.

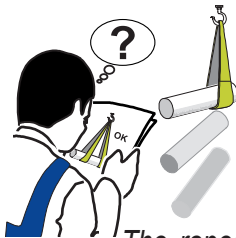

The ropes and equipment used for lifting must be suitable for bearing the weight of the equipment.

FIMER usually stores and protects individual components by suitable means to make their transport and subsequent handling easier, but as a rule, it is necessary to utilize the experience of specialized staff in change of loading and unloading the components.

Do not lift several units or parts of the equipment at the same time, unless otherwise indicated.

Unpacking and checking

Packaging elements (cardboard, cellophane, staples, adhesive tape, straps, etc.) may cause cuts and/or injuries if not handled with care. They should be removed with the proper equipment.

The components of the packaging must be disposed on in accordance with the regulations in force in the country of installation.

When you open an equipment package, check that the equipment is undamaged and make sure all the components are present. If you find any defects or damage, stop unpacking and consult the carrier, and also promptly inform v Service.

Storage

If the package with the power module part is stored correctly, it can withstand a maximum load of 2 stacked units (power module+wiring box+bracket).

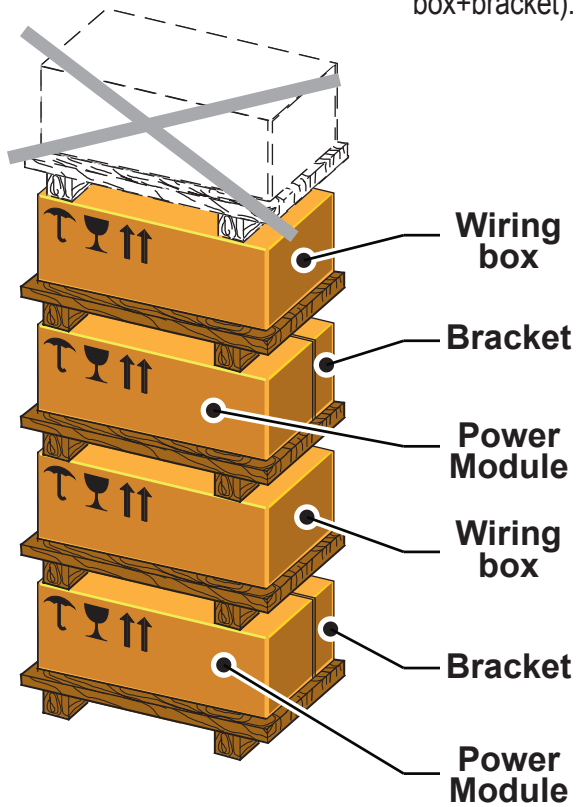

*DO NOT stack with equipment or products other than those indicated.
Accessory components are in separate packages and can be piled separately*

Equipment weight

Device	Weight (kg/lb)	Lifting points	Holes for handles (optional) or Eyebolts UNI2947 (not supplied)
Power module	70 kg / 154 lbs	4	M8. Kit of handles 04 (to be ordered)
Wiring box	~ 55 kg / 121 lbs	4	M8. Kit of handles 04 (to be ordered)

Types of lifting

FIMER usually stores and protects individual components by suitable means to make their transport and subsequent handling easier. Nonetheless, as a rule, it is necessary to turn to the experience of specialised staff to take charge of loading and unloading components.

The power module and the wiring box must be lifted using the 4 handles 04 (to be ordered) or alternatively using suitable lifting equipment.

The means used for lifting must be suitable to bear the weight of the equipment.



In case of manual lifting the number of required operators necessary to lift the equipment must be in accordance to local regulations relating lifting limits per operator



Risk of injury due to the heavy weight of the equipment!

The handles 04 must be mounted into the designated holes located on the enclosures.

If lifting with ropes, M8 eyebolts can be mounted in the same holes.



Handling and installation operations shall be performed only by using the special tools and accessories provided with "PVS Installation Kit" that have to be ordered separately. The use of these equipment are mandatory to safely install the inverter. Refer to "Kit of recommended spare parts" chapter content in the product manual for further information.



DO NOT grab the equipment from the rear flange!
Risk of injury due to cutting surfaces and risk of equipment damage.

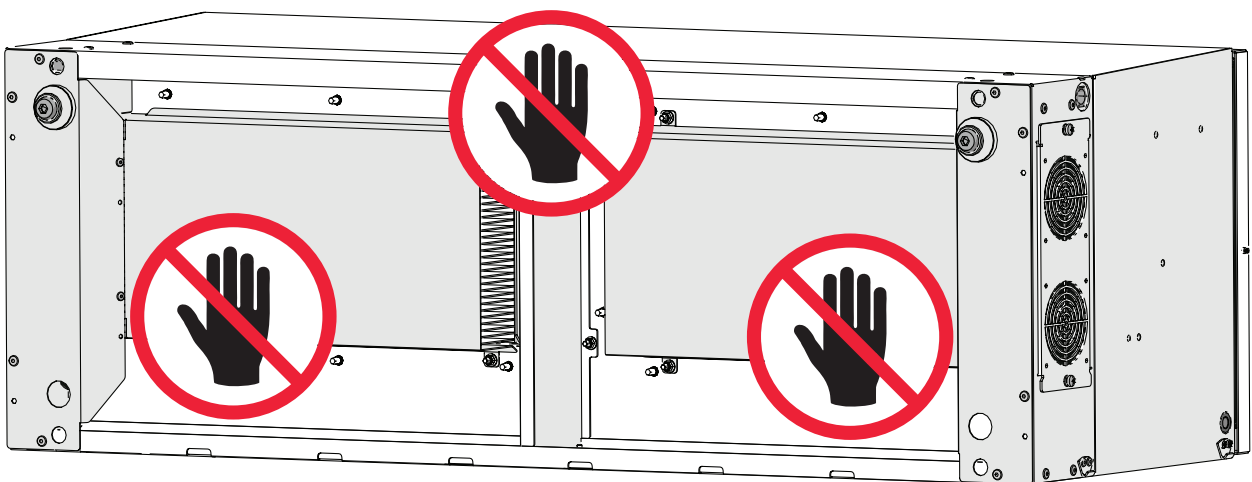

The following table shown examples about types of lifting:

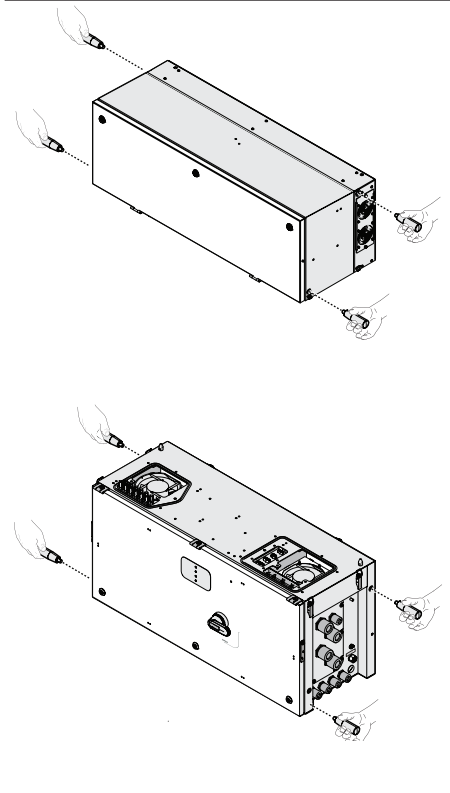
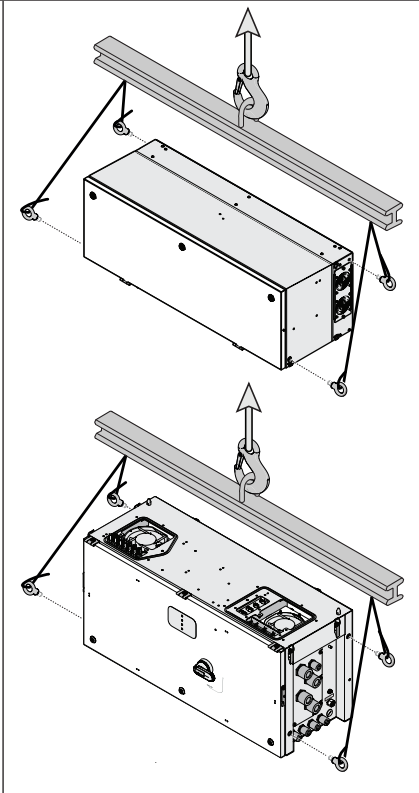
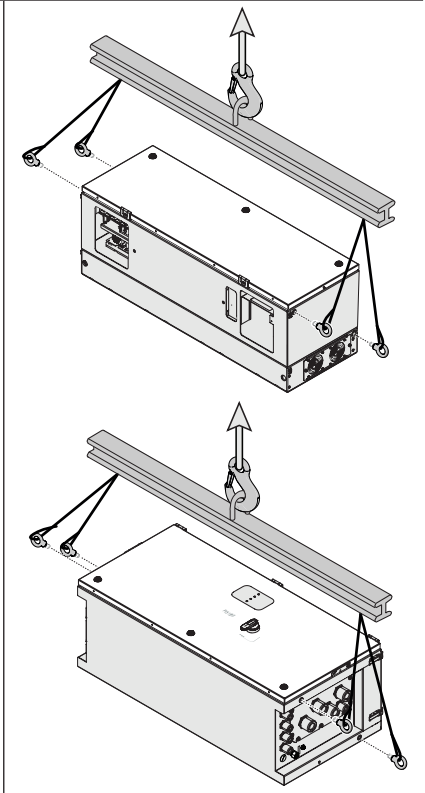
Manual lifting (handles)	Vertical lifting (eyebolts and lifting balancer)	Horizontal lifting (eyebolts and lifting balancer)
		
<p>M8. Kit of handles 04 (to be ordered)</p>	<p>M8. Hole for Eyebolts UNI2947 (not supplied) *lifting balancer must be 20 cm longer (per side) than the lifted device.</p>	<p>M8. Hole for Eyebolts UNI2947 (not supplied) *lifting balancer must be 20 cm longer (per side) than the lifted device.</p>

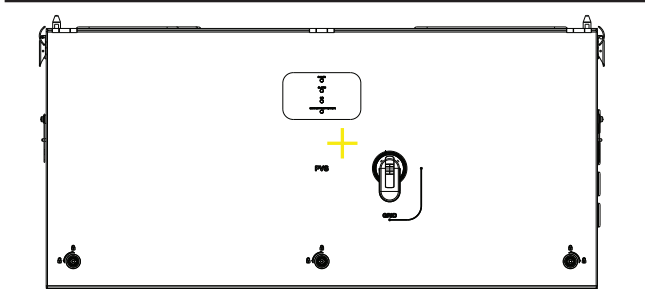
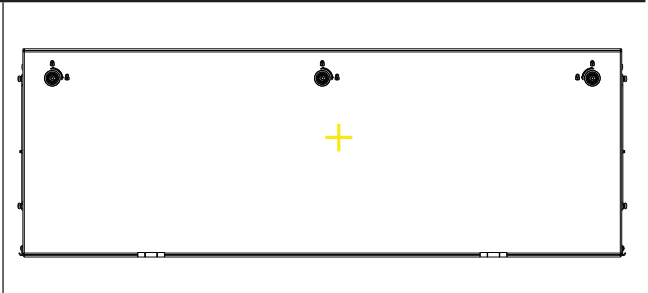
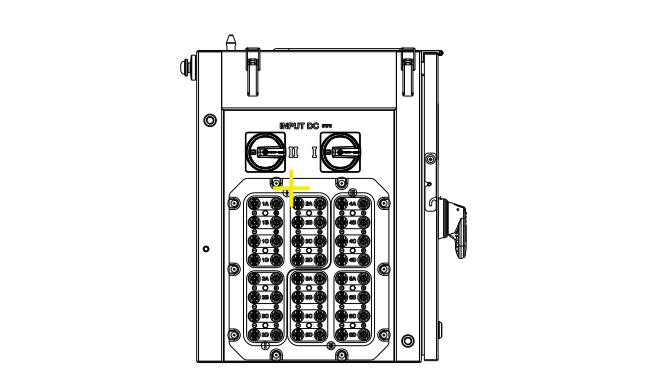
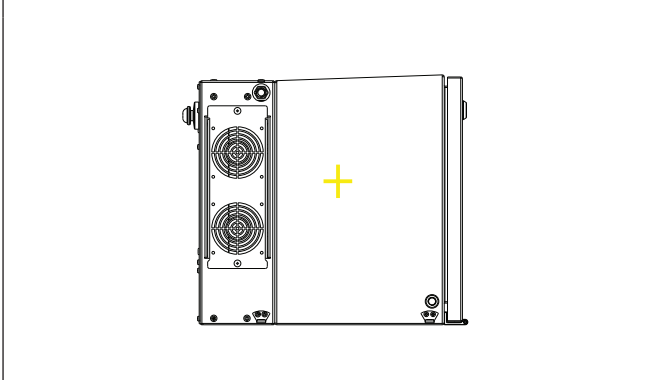

Always consider the center of gravity of the enclosures while lifting.

Center of gravity (wiring box)	Center of gravity (power module)
	
	





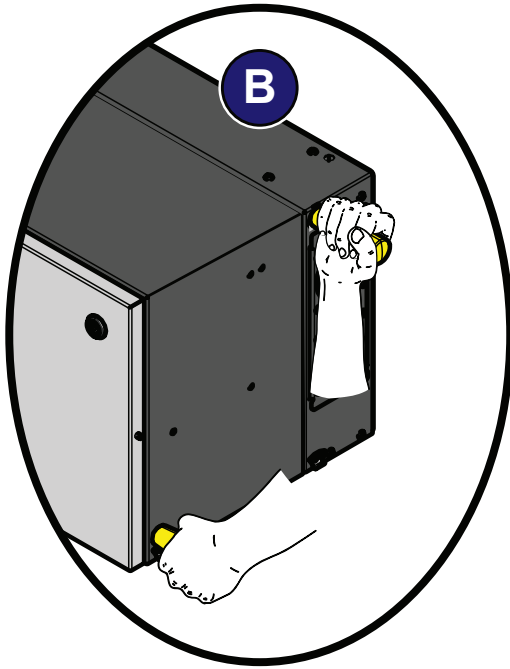
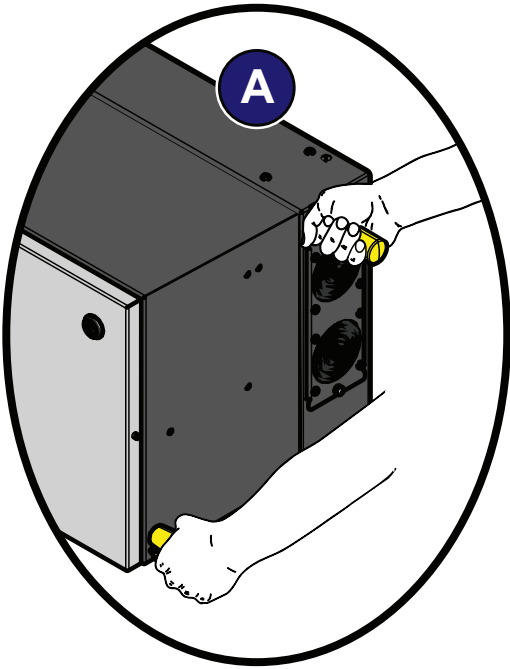
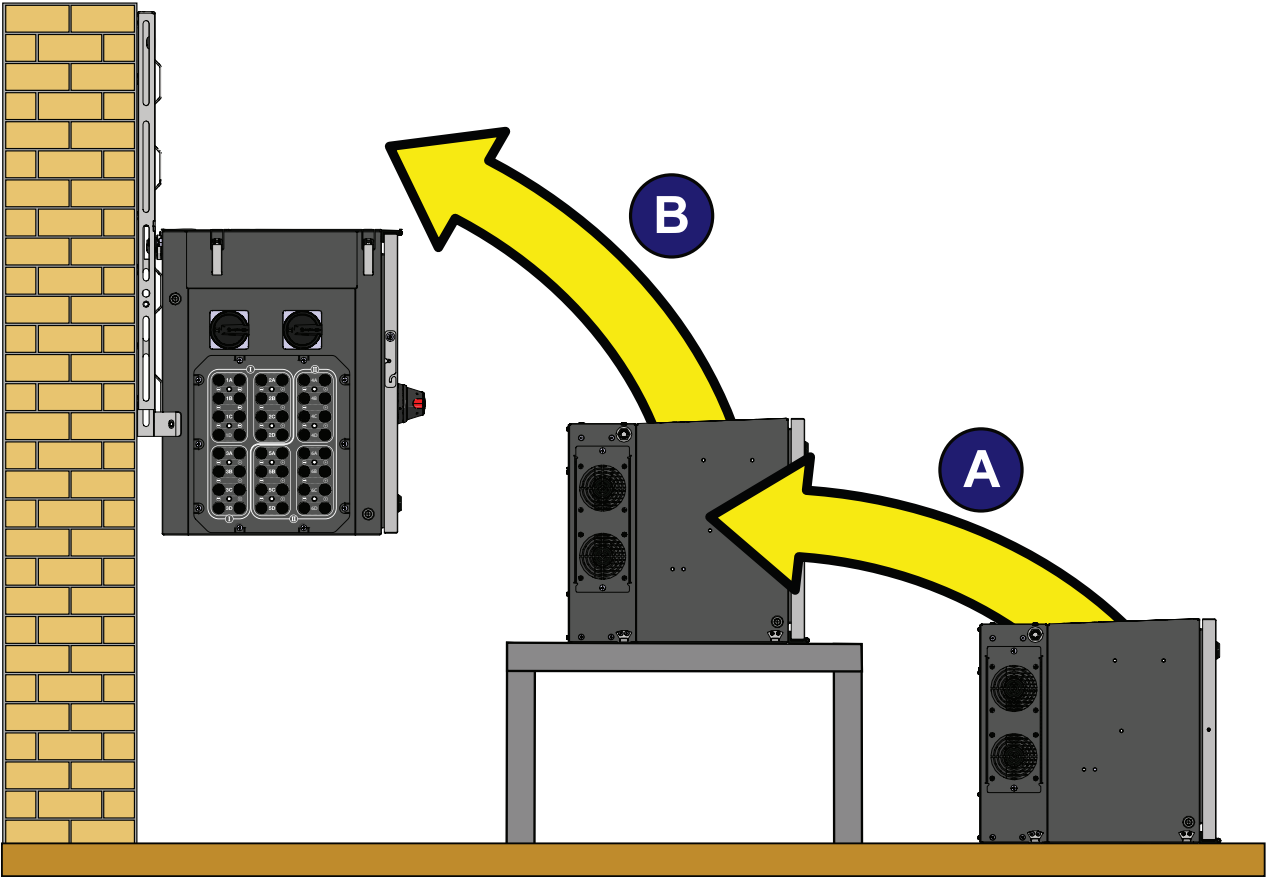





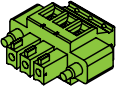
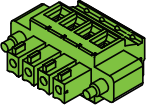

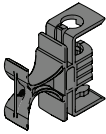

In case of manual lifting it's suggested to use a support plan (e.g. a table) to place the equipment during the lifting operation, to allow the change of hands position.

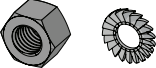

List of components supplied

The following list shown the supplied components required to correctly install and connect the inverter.

Available components for wiring box		Qty
	Multifunction relay, aux relay and RS-485 connector (pre-installed on communication board 28)	4
	Remote ON/OFF connector (pre-installed on communication board 28)	1
	Two-hole gasket for M25 signal cable glands 12 and cap	1 + 1
	Fuse holder for positive string fuses 19	24
	Positive string fuses 19 (gPV - 1000Vdc - 15A)	24
	South africa network standard label	1
	Key tool for front cover quarter cam-lock	1
	Technical documentation	-
Available components for power module		Qty
	Coupling screw between wiring box and power module	2
	M16 screws with washer to clamp internal AC cables on AC interconnection board 58	3
	M5 hex nuts + M5 serrated lock washers to clamp internal earth cable to the power module	1 + 2
	Technical documentation	-
Available components for bracket		Qty
	M8 screws with washers for mechanically securing the half-brackets	2
	M6 screws for mechanically securing the bracket with the wiring box	2

Kit of recommended spare parts

A list of spare parts that are compatible with the inverter available (at the FIMER warehouse) is given below:

Code	Description	Quantity
PVS INSTALLATION KIT	Handle (M8)	4
	M8 to M12 adapter	4
	Gasket protective cover (temporary installation)	2
	Cover locking key	1
	IP66 protection covers protection covers for wiring box openings (long term installation) with screws	2 (with 8 screws)
KIT 24 FUSES 12A	Kit of 12A fuses (gPV - 1000Vdc)	24
KIT 24 FUSES 15A	Kit of 15A fuses (gPV - 1000Vdc)	24
KIT 24 FUSES 20A	Kit of 20A fuses (gPV - 1000Vdc)	24
KIT 24 FUSES 30A	Kit of 30A fuses (gPV - 1000Vdc)	24
SPD BOARD.PVS-100(120)-TL/B_For Service Activity	DC surge arresters (type 2) board (only for -SX and -SX2 models)	1 board
KIT SURGE AC SIDE PVS	Kit of spare cartridges for AC surge arresters type 2	4 (Mersen P/N is 83020003 / SP2-40K320V)
PVS FAN KIT	Kit of fans: 2x2 external fans for power module, 1 internal circulating air fan for power module, 2 internal air circulating fans for wiring box	2 external fans 1 internal power module fan 2 internal wiring box fans
AC MULTICORE CABLE GLAND PLATE	AC multicore cable gland plate (Supports M63 Ø37...53mm + M25 Ø10...17mm)	1

General conditions

The device is intended to be installed in a suitable plant for its use and its purpose. All the installation instruction described in this chapter must be followed considering the plant structure where the device is intended to be installed. Its performance therefore depends on the correctness of the installation.

The installation operations must be carried out by qualified personnel and it is mandatory to adhere to the indications provided in this manual, the diagrams and the enclosed documentation, paying attention to follow the installation sequence exactly as described in this manual.



Staff authorised to carry out the installation must be specialised and experienced in this job. They must also have received suitable training on equipment of this type.



The installation must be performed by qualified installers and/or licensed electricians in accordance with the existing regulations in the country of installation.



The inverter panels/covers can be removed from authorized service personnel only. (the users is not authorized to remove inverter panels/covers).



Connection of the photovoltaic system to an electric installation connected to the distribution grid must be approved by the electricity provider.



The installation must be carried out with the equipment disconnected from any voltage sources. Refer to “Inverter total de-energization and safe access” chapter on this manual to know all the necessary step to safely operate on the inverter.



When the photovoltaic panels are exposed to sunlight they provide continuous DC voltage to the inverter.

Installation site and position



Please refer to the warranty terms and conditions to evaluate any possible warranty exclusions due to improper installation.

General recommendation on installation position

- See characteristics and technical data paragraph to check the required environmental conditions (protection rating, temperature, humidity, altitude, etc.).
- The installation location shall be easily accessible.
- Installation of the unit in a location exposed to direct sunlight NOT acceptable. (Add awning in case of direct sunlight installation).
- Final installation of the device must not compromise access to any disconnection devices that may be located externally.
- Do not install in small closed rooms where air cannot circulate freely.
- Always ensure that the flow of air around the inverter is not blocked so as to prevent overheating.
- Do not install in locations where flammable substances or gases may be present (minimum distance 3 m).
- Do not install on wooden walls or other flammable supports.
- Install on a wall or strong structure suitable to bear the weight.
- Do not install in rooms where people live or where the prolonged presence of people or animals is expected, because of the high noise that the inverter produces during operation. The level of the sound emission is heavily influenced by where the appliance is installed (for example: the type of surface around the inverter, the general properties of the room, etc.) and the quality of the electricity supply.

Tilting admittance

- The installation can be carried out vertically or horizontally, with a maximum inclination as indicated in the figures.

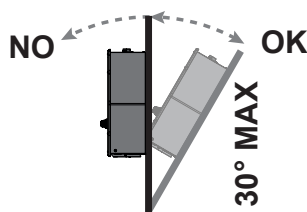

Vertical tilting

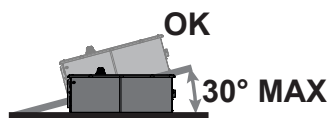

Horizontal tilting

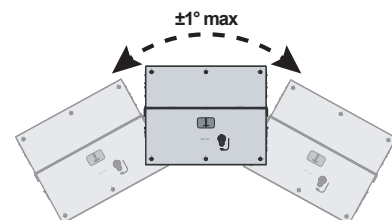

Side tilting



In case of horizontal installation in outdoor environment consider an installation with a minimum tilt of 3° to avoid any water stagnation.

Distances

- Hardware and software maintenance on device entails removing the front cover. Check that the correct installation safety distances are observed in order to allow routine check and maintenance operations.
- Provide sufficient working space in front of the inverter that allows to open the front covers and to make the internal connections.

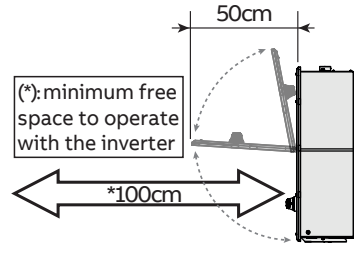

- Install at a height which takes into consideration the weight of the appliance and in a position which is suitable for servicing, unless suitable means are provided to carry out the operation.
- If possible, install at eye-level so that the status LEDs can be seen easily.
- Respect the minimum distances from objects around the inverter that could prevent the inverter installation and restrict or block the air flow.

MINIMUM CLEARANCE DISTANCES

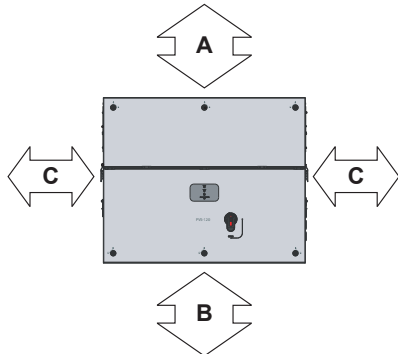

The minimum clearance distances depends from multiple factor:

- Ventilation flow on the rear side of the inverter. Depending of the support where the inverter is installed it changes the upper (A) required free space: if the inverter is installed on a support without any openings (e.g. a wall), the heat flow will be entirely directed to the top of the inverter; for this reason the upper (A) minimum required free space must be **50 cm**. Otherwise in case of the inverter is installed on a support with openings (e.g. frame installation) the heat can freely flow on the rear side of the inverter; so the upper (A) minimum required free space can be reduced to **15 cm**.

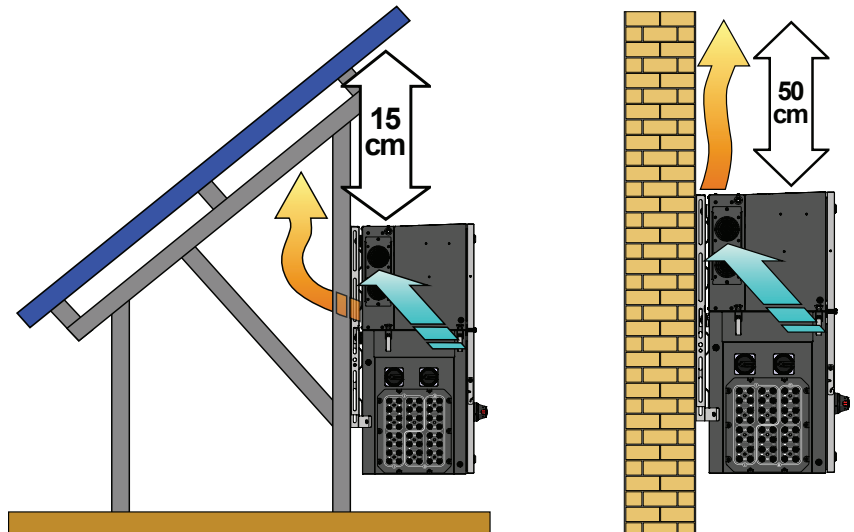

**MINIMUM CLEARANCE REAR DISTANCE
(ONLY FOR HORIZONTAL INSTALLATION)**

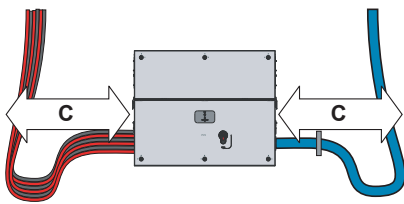
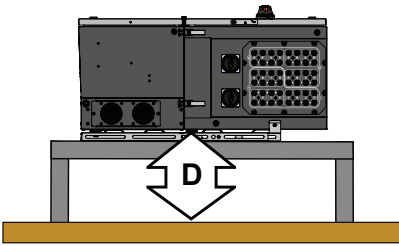

- **Possible flooding or grass cutting evenience.** It changes the bottom (B) or the rear (D - only in case of horizontal installation) required free space: If the inverter is installed in a place where there are concrete risk of flooding or grass cutting evenience, the bottom (B) or the rear (D - only in case of horizontal installation) minimum recommended free space is **50 cm**; otherwise in case of the inverter is installed in a place where there aren't risk of flooding or grass cutting evenience, the bottom (B) and rear (D - only for horizontal installation) minimum required free space must be **15 cm**.

- **Cables bending radius.** Sides (C) minimum required free space may depends from cable type (cable dimension, bending radius, etc.): this evaluation must be done by the installer during the plant design phase (refer to "Cable routing" chapter for more information). In any case minimum required free space for proper ventilation of the unit (near side fans) cannot be under **15 cm** on the right side and **30cm** on the left side.



*In case of manual installation (using handles) consider a free side space to lift the inverter of **60 cm minimum**.*



In case of installation with lifting equipments (eyebolts and ropes) the side distances (C) could be reduced at the minimum required but a subsequent manual lifting it will no longer be possible: in this case the lifting equipments must remain available on the field for any subsequent operation.

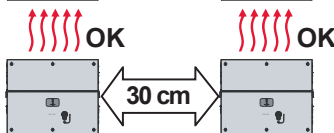
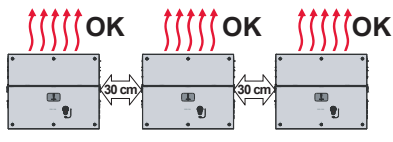

Installation of multiple units

• When installing multiple units position the inverters side by side paying attention to keep the minimum clearance distances (measured from the outer edge of the inverter) for each inverter specified in the side graphs.

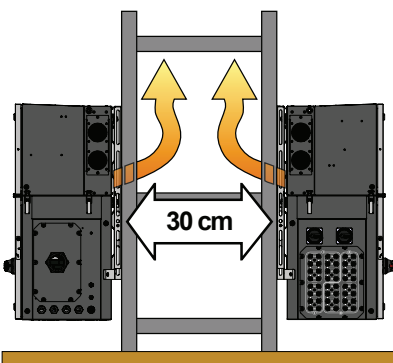

• The vertical installation of two inverters positioned back to back is also permitted on a structure which must be composed of a 2 or 3 frame supports (refer to "Mounting with a support bracket" paragraph). In this case the minimum recommended distance between the units in order to avoid the use of an air deflector is 30cm.

Wireless signal environmental checks

The inverter can be commissioned and monitored using the wireless communication channel. The WLAN board of the inverter uses radio waves to transmit and receive data, it is therefore important to assess this factor in order to have optimal installation.

- Walls in reinforced cement and surfaces covered in metal (doors, shutters, etc.) can markedly reduce the reach of the device which even in optimal conditions, should be of approximately 40 metres in free space.
- It is therefore recommended that before installing the inverter, the strength of the wireless signal is checked, using a mobile device (smartphone, tablet or notebook) and connecting to the wireless router from a position which is close to the installation site of the inverter.

The radio signal level between the inverter and the wireless router can be improved in a number of ways:

1. Find a new position for the router considering the different types of materials which the radio signal will have to pass through:

Material	Relative signal reduction
Open field	0% (strength of approximately 40 metres)
Wood / Glass	From 0 to 10%
Stone / Plywood	From 10 to 40%
Reinforced concrete	From 60 to 90%
Metal	Up to 100 %

The quality of the RF signal can be assessed during the installation stage where the signal is displayed in dBm.

2. Install a wireless signal repeater and place it in an area between the inverter and the router, trying to make sure that the most critical obstacles are avoided.

Installations above 2000 metres



On account of the rarefaction of the air (at high altitudes), particular conditions may occur that should be considered when choosing the place of installation:

- Less efficient cooling and therefore a greater likelihood of the device going into derating because of high internal temperatures.
- Reduction in the dielectric resistance of the air which, in the presence of high operating voltages (DC input), can create electric arcs (electrical discharges) that may damage the device.

As the altitude increases, the failure rate of some electronic components increases exponentially because of cosmic radiation.



All installations over 6500' (2,000 meters) must be assessed by FIMER Technical Sales to determine the proper datasheet derating.

Installations with a high level of humidity



Never open the inverter in the case of rain (even light rain), snow or a level of humidity >95%.

Always carefully seal all unused openings. In case of opening when the unit is wet, avoid any water infiltration inside the unit, either in WB or PM.

Even though the device is equipped with an anti-condensation valve, air with extremely high levels of humidity can lead to the creation of condensation inside the inverter.

As the inverter is almost completely insulated from the outside, condensation can also form after installation in certain weather conditions.

Installations of IP66 protection covers for wiring box openings (long term installation)



Never leave the power module or the wiring box disassembled on the field. In case is necessary to install the wiring box only, a IP66 protection covers for wiring box openings (long term installation) kit is available as accessory options.

To install the protection covers place them over the wiring box openings and fix it using the 8 x M5 screws provided with the PVS INSTALLATION KIT.



Some wiring box parts may be subject to voltages that could be hazardous for the operator. Before performing any work on the inverter, refer to “Inverter total de-energization and safe access” paragraph (chapter 8) on this manual to know all the necessary step to safely operate on the inverter.

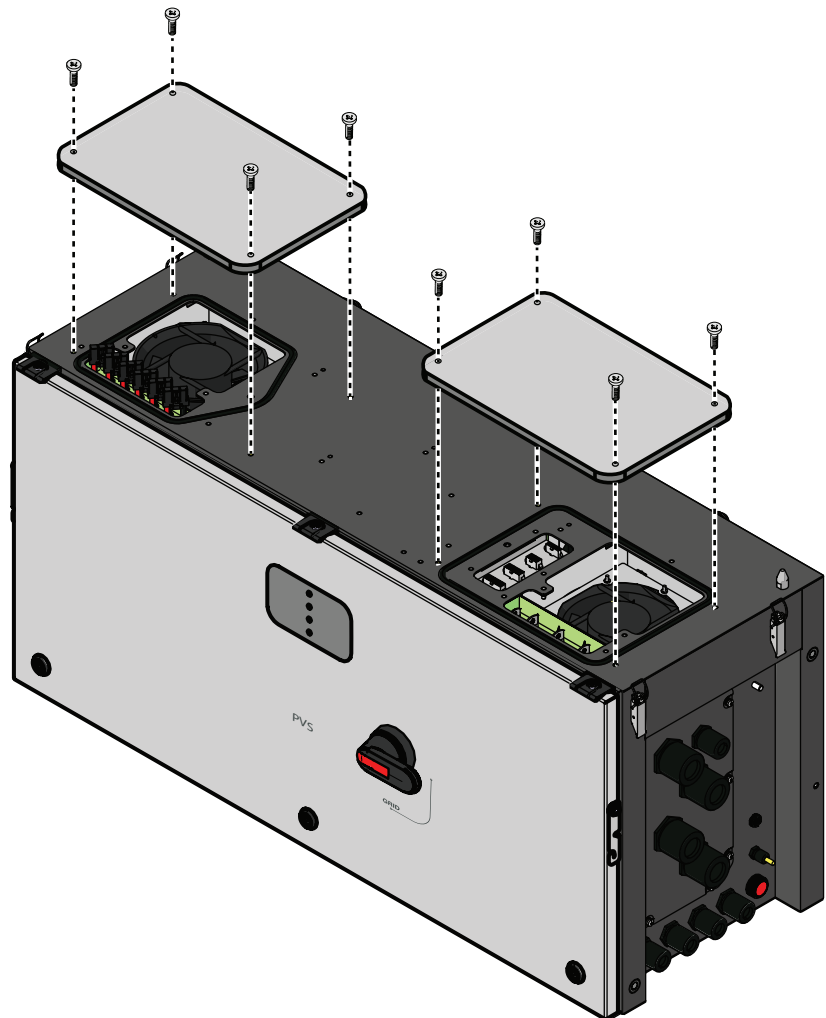

Mounting with a support bracket

Independently from the mounting on vertical supports (wall, profiles) or horizontal supports the assembly instruction are the same (the differences will be detailed on the procedure steps). The assembly instruction steps below are related to vertical mounting.

Bracket assembly

- Assemble the two side bracket pieces together with the central bracket, by sliding it as shown in the picture and paying attention to the orientation of the pieces (refer to arrow and "UP" markings on the brackets): side brackets arrow have to be turned downwards, central bracket have to be turned upwards.

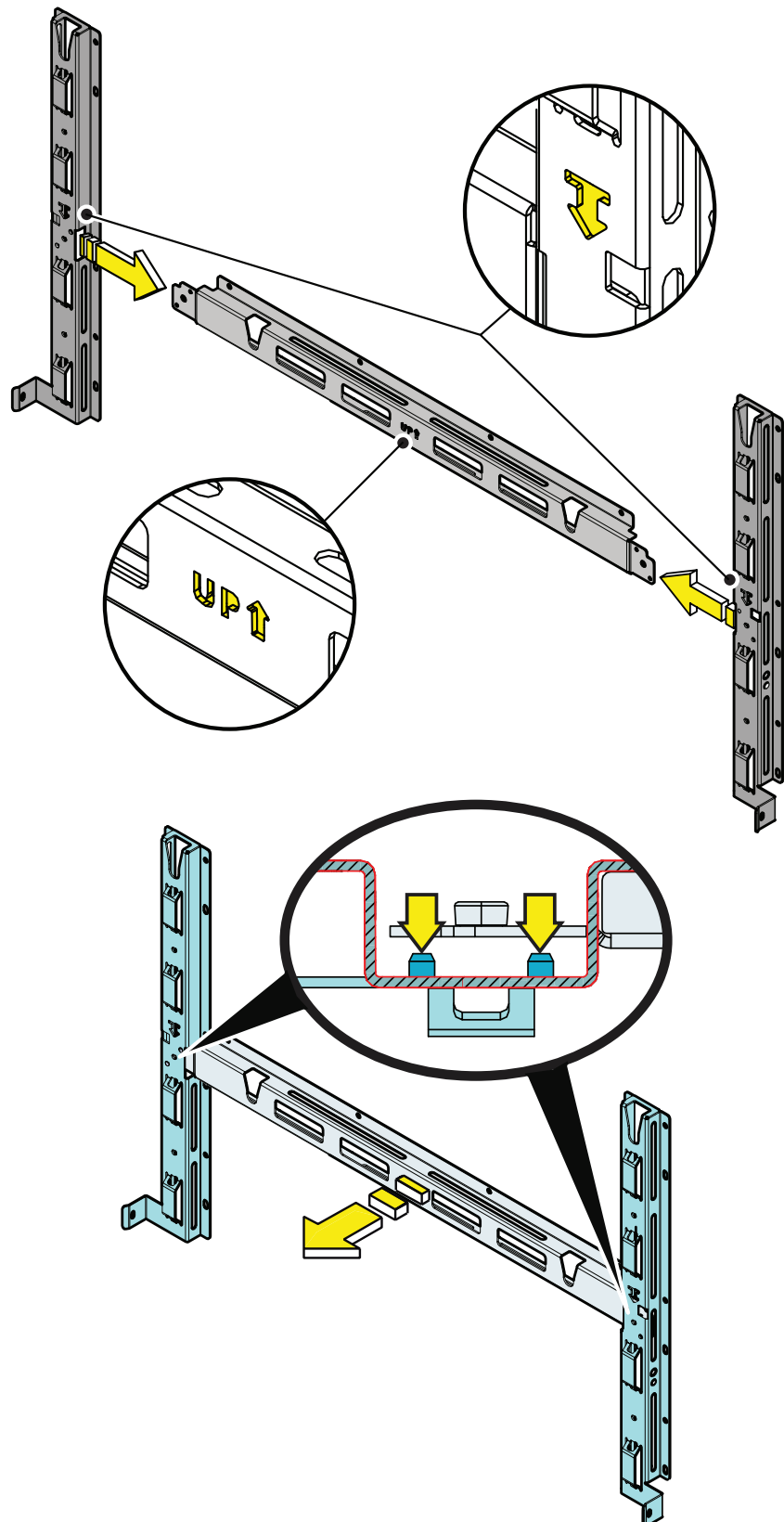

- Slide the central bracket in order to match the two holes with the centering pins of the side brackets.

- Use the two M8 screws with flat and spring washers (supplied) to fix the pieces of the bracket together.

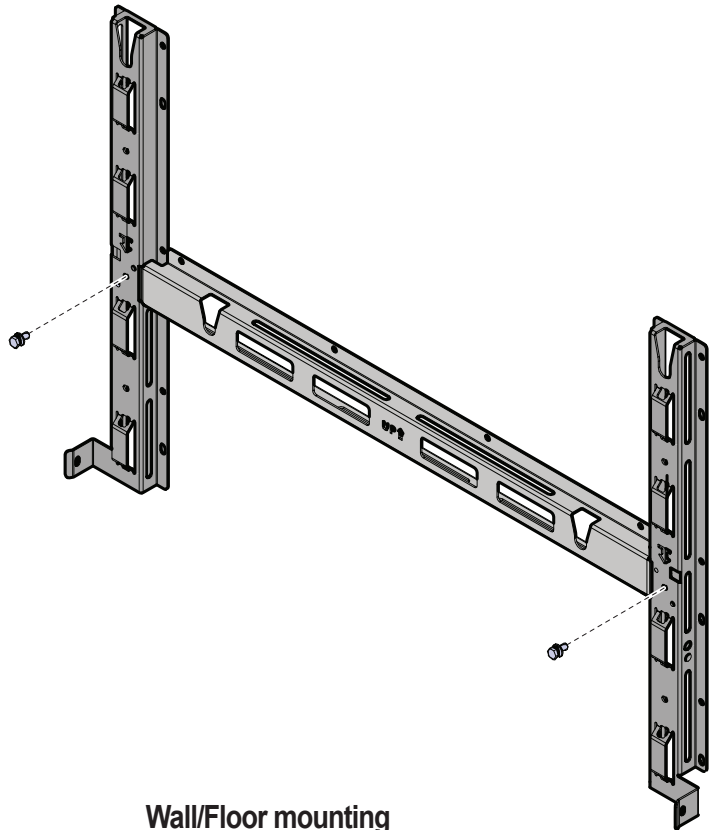

- Position the bracket 03 perfectly level on the support and use it as drilling template.

Consider the overall dimensions of the power module and the wiring box.

- It is the installer's responsibility to choose an appropriate number and distribution of attachment points. The choice must be based on the type of support (wall, frame or other support), the type of anchors to be used, and their ability to support 4 times the inverter's weight ($4 \times 125\text{Kg} = 500\text{Kg}$ for all models).

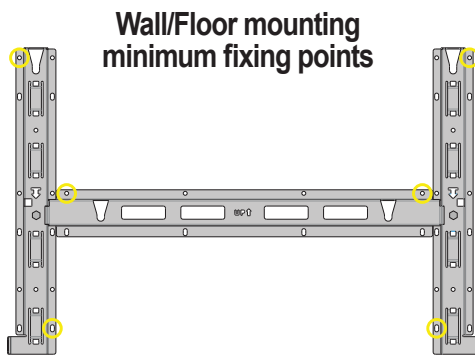

- Attach the bracket 03 to the support with at least 6 attachment screws (shown in RED) or at least 6 frame fixing bracket for frame mounting (shown in BLUE).

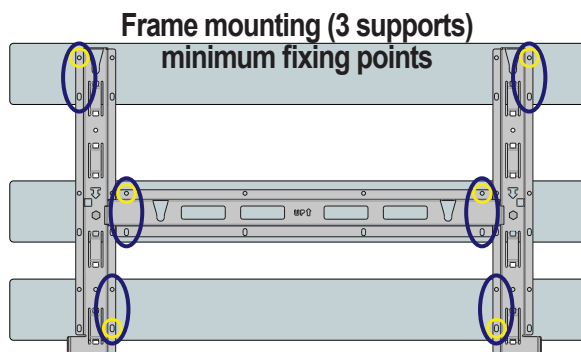

Depending on the type of anchor chosen, drill the required holes to mount the bracket 03. The pictures shown the recommended minimum fixing point depending to the type of support.

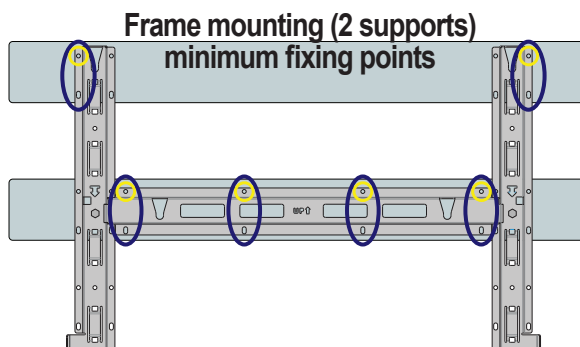



In case of use of “frame fixing brackets” (see side picture as example) it will be possible to fix the bracket to the frame structure without drill any additional holes.

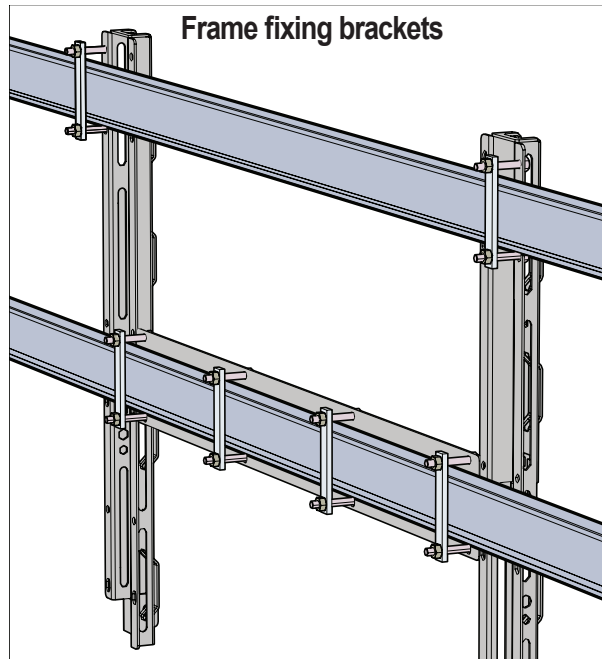

- Fix the bracket 03 to the support.

Assembly the Inverter to the bracket

- Lift the wiring box up to the bracket using the (optional) handles 04 or the (optional) M12 eyebolts, or another appropriate lifting device.



Risk of injury due to the heavy weight of the equipment.

- Insert the heads of the two rear attachment pins 13 (placed on the rear part of the wiring box) into the two slots on the bracket. **Check that the pins 13 has been correctly inserted in the slots as shown in the picture before releasing the wiring box.**

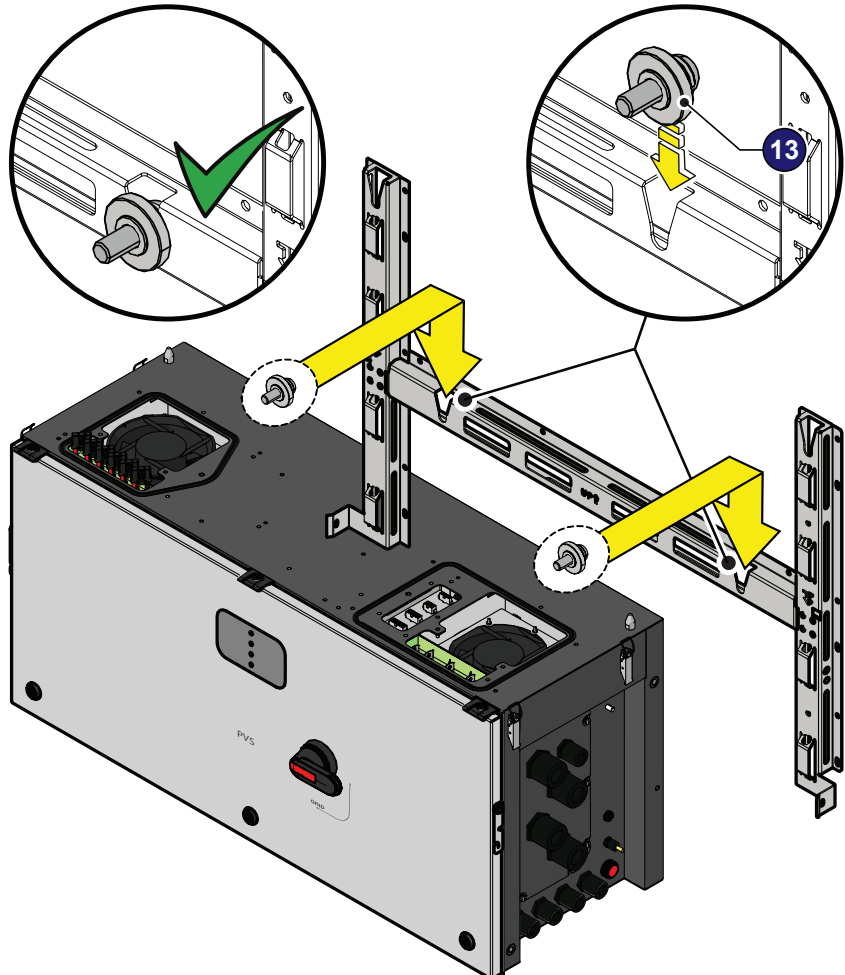

- Remove handle or other lifting device (if used)

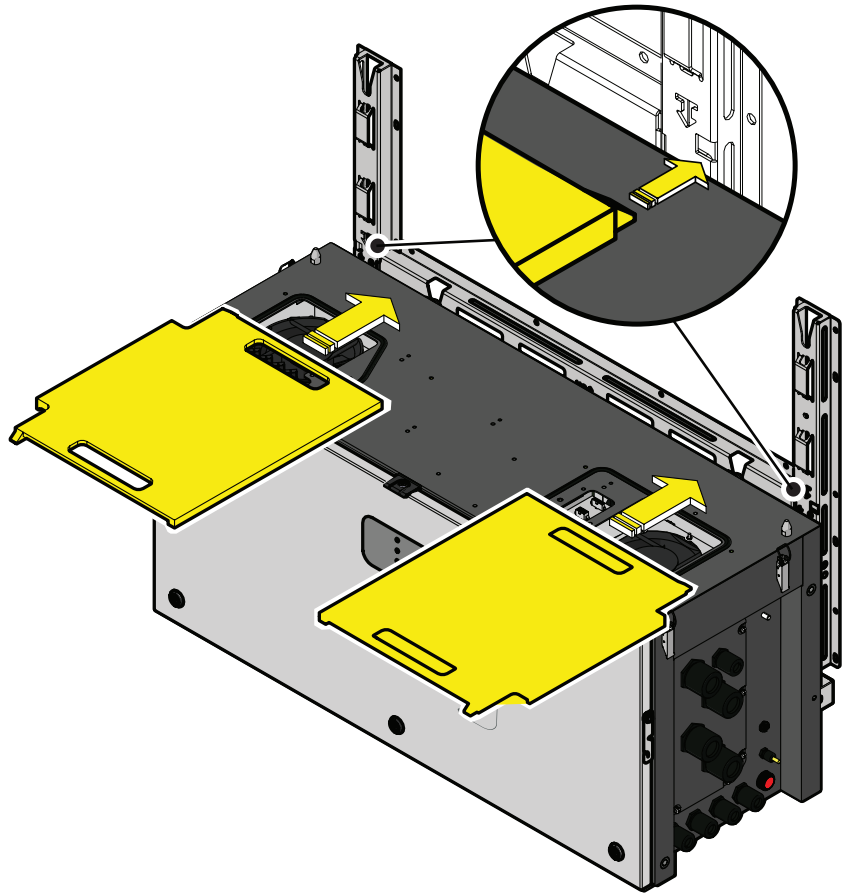

- Only for vertical mounting: Insert the two gasket protective covers (contained in the installation kit) and slide them till the positioning pins are into the proper bracket holes. If the mounting is correct the gasket protective cover will have a locked position.

- Lift the power module up to the bracket and over the wiring box, using the (optional) handles 04 or the (optional) M12 eyebolts, or another appropriate lifting device.



Risk of injury due to the heavy weight of the equipment.

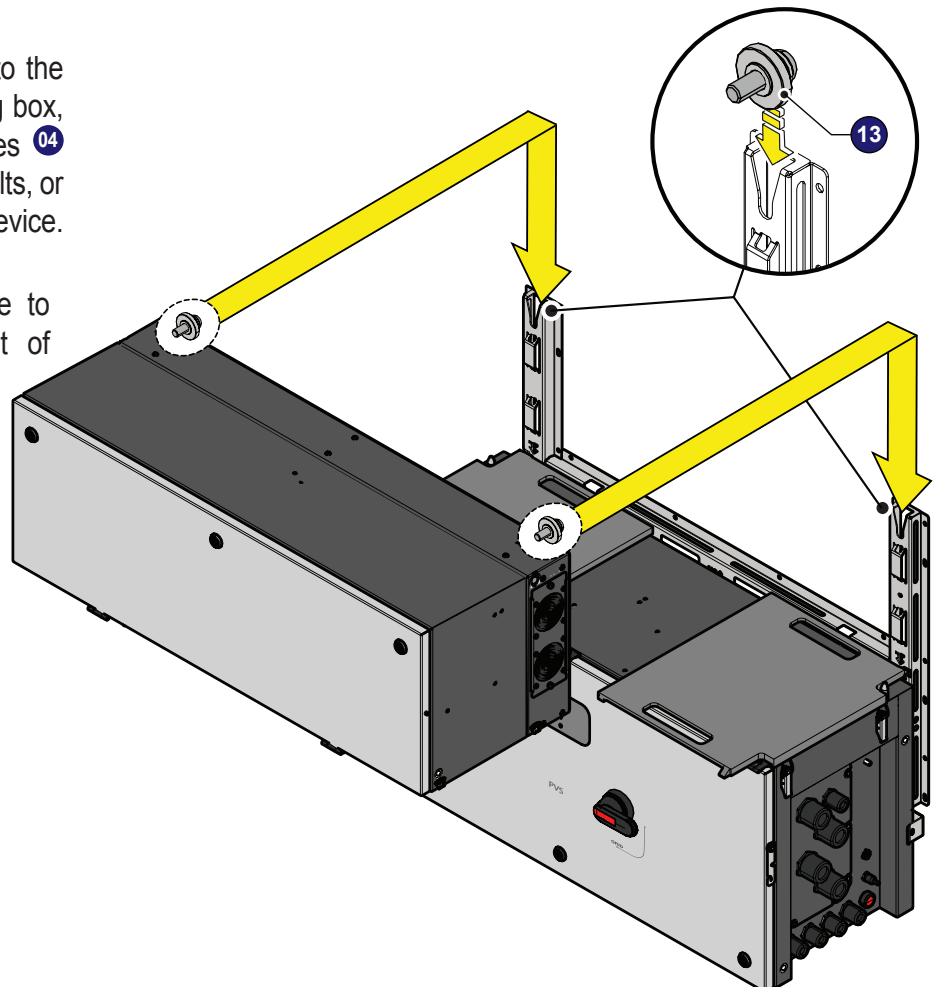

- Insert the heads of two rear attachment pins 13 (placed on the rear part of the power module) into the slots T on the bracket. For horizontal mounting, the two markings A on the bracket indicate the point where the edge of the power module have to be placed to allow the engagement of the rear attachment pins 13.

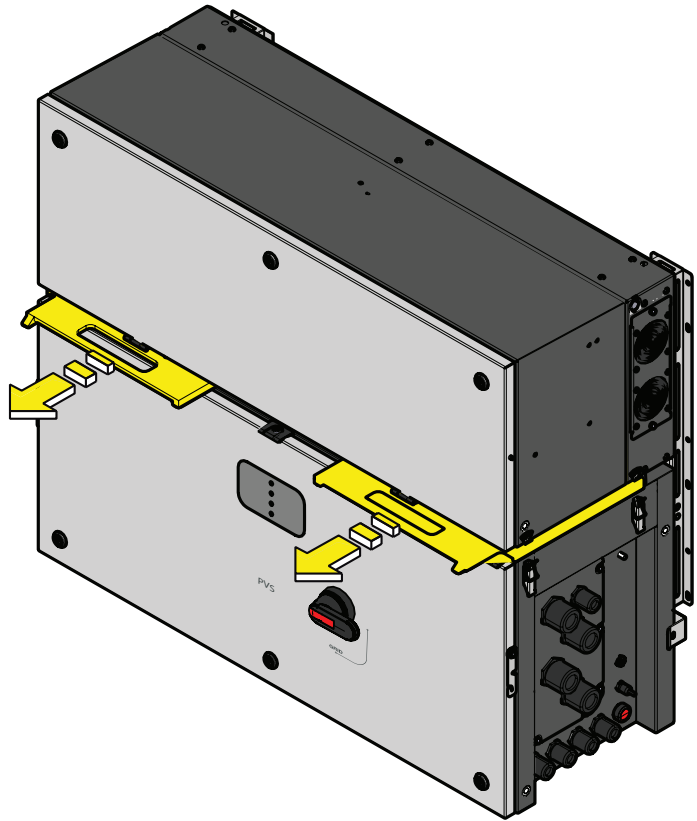

- Only for vertical mounting: Remove the previously installed gasket protective covers from the inverter by slidding it pulling from the handles.



Gasket protective covers and handles can be reused for a new installation

- Fasten all of the four side latches 06 as shown in the pictures.

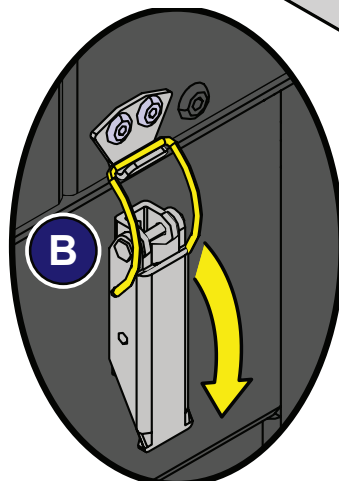
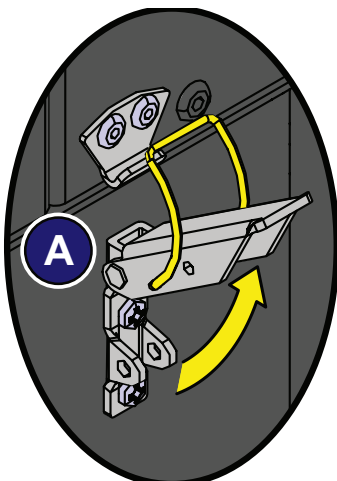
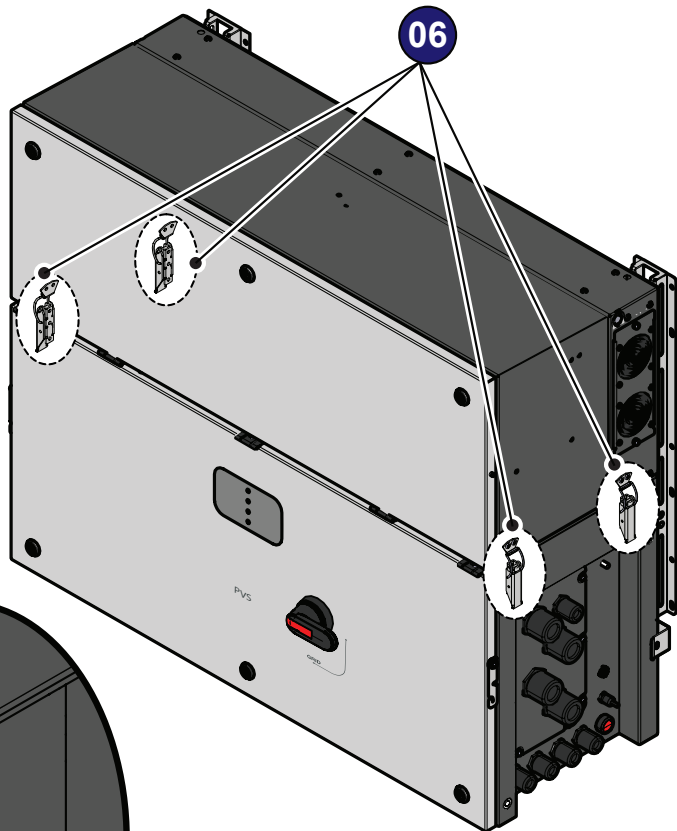

Opening the cover

- Using the key tool provided with the component kit content in the wiring box package, open the three cover quarter cam locks ⑮ following the proper ways as shown in the related silkscreens on the cover.

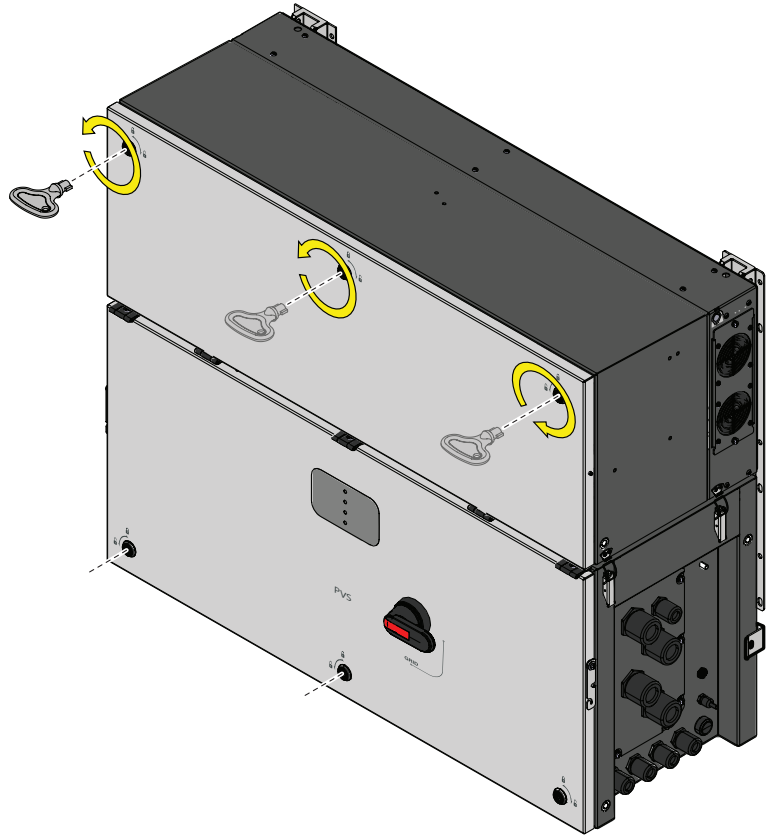

- Open the cover and use the cover support brackets ⑭ to lock the cover in open position.



Pay attention to properly secure the cover support brackets ⑭ in order to avoid damaging of the cover!

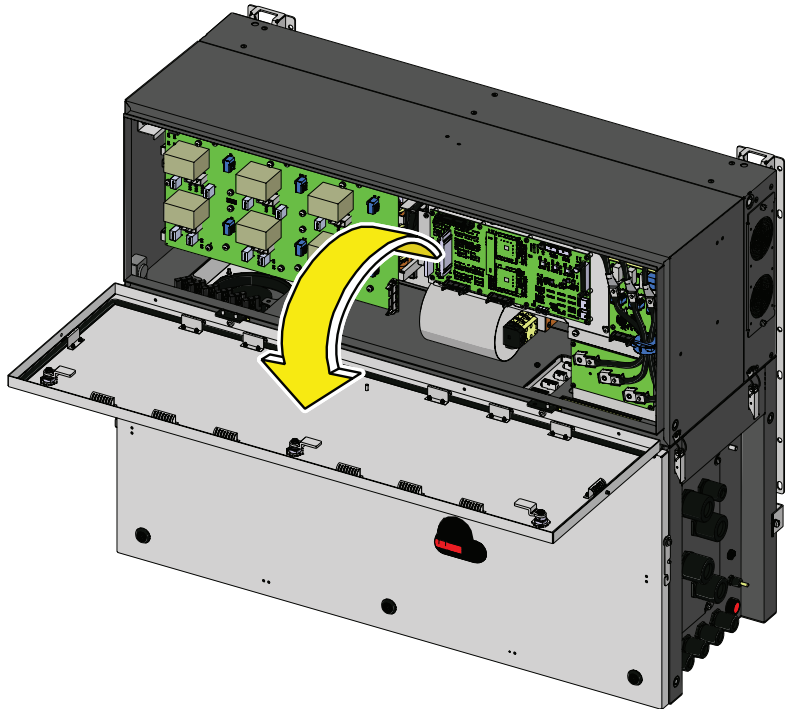

Final fastening operations

- To reach the two junction screws and complete the power module and the wiring box coupling, open the front panel of the power module and screw the two screws as shown in the figure
- Tighten the two hexagonal junction screws ⑱ with a tightening torque of 4.7 Nm.

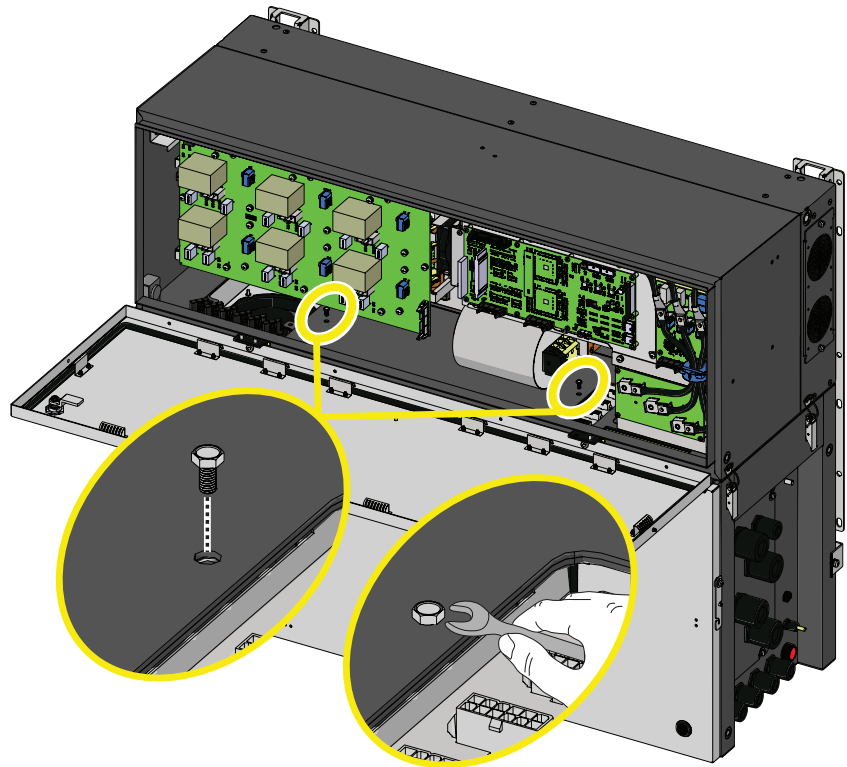

- Tighten the two side screws (supplied) with a tightening torque of 5 Nm, to avoid the tilting of the bottom part of the inverter.

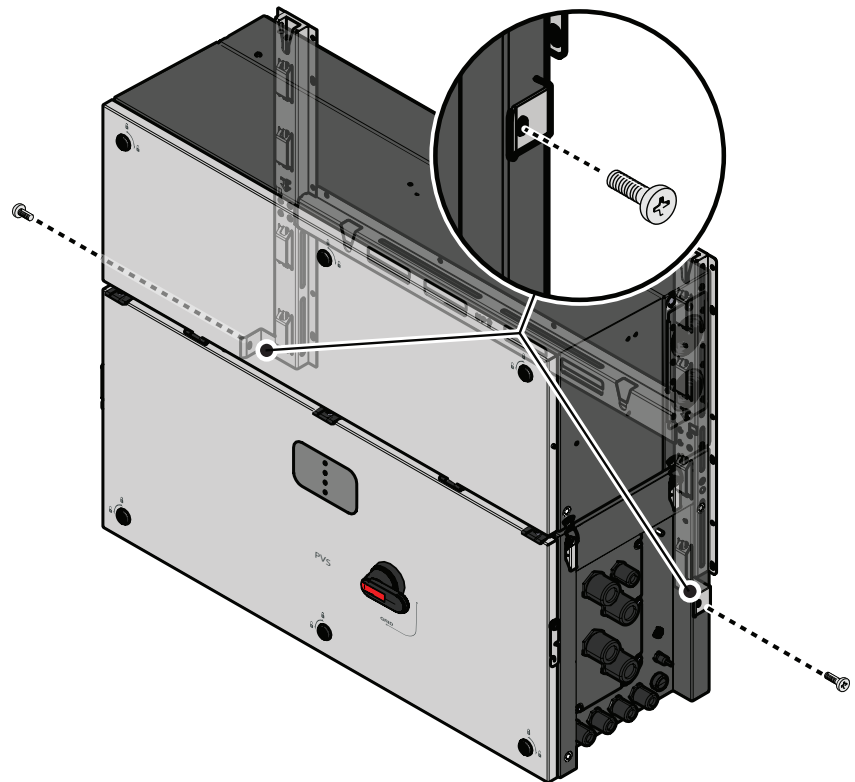

Interface connectors connection

Last operation before proceed with the wiring and connections of AC and DC sources is to connect the interface connectors that allow the power and the communication connection between the power module 01 and the wiring box 02:

Connection of the AC interface cables:

- Connect the R, S, T cables coming from the wiring box to the respective anchor points R, S, T in the AC interconnection board 58 using the screws supplied with the power module component kit (tightening torque 4Nm).
- Connect the earth cable to the dedicated point next to the AC interconnection board 58 (see the picture) using the M5 nut and the two serrated lock washers supplied with the power module component kit (tightening torque 2Nm).

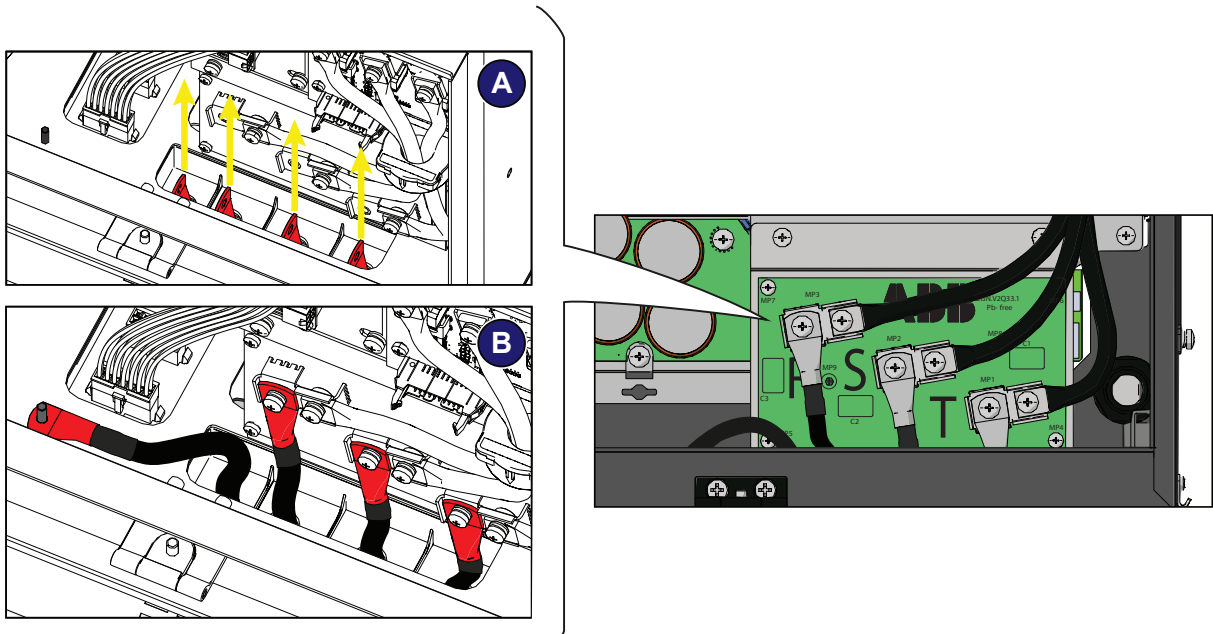

Connection of the DC interface cables:

- Connect the 6 connectors coming from the wiring box in the dedicated connectors of the DC interconnection board 59

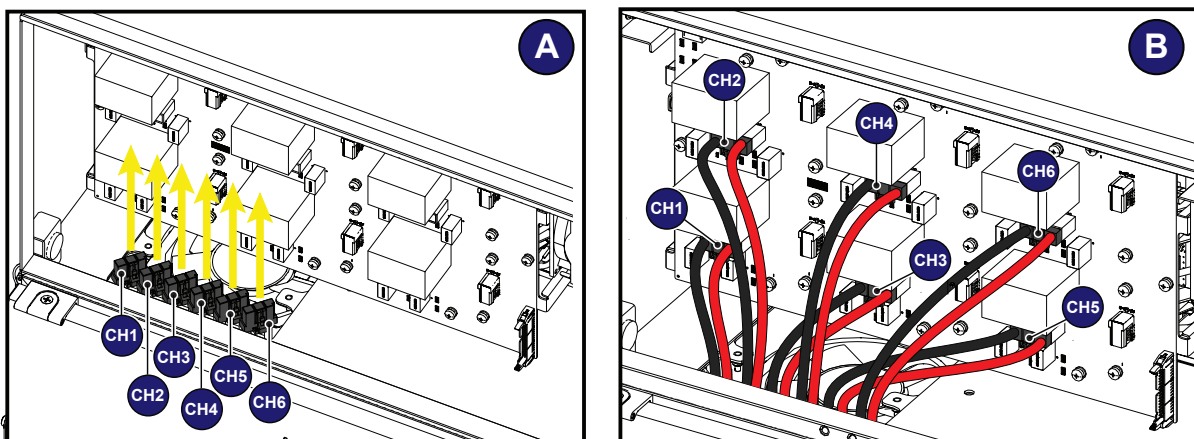

Connection of the signal interface cables:

- Connect the signal interface cables on the related interface signal connectors ③⑩ starting from the back connector.

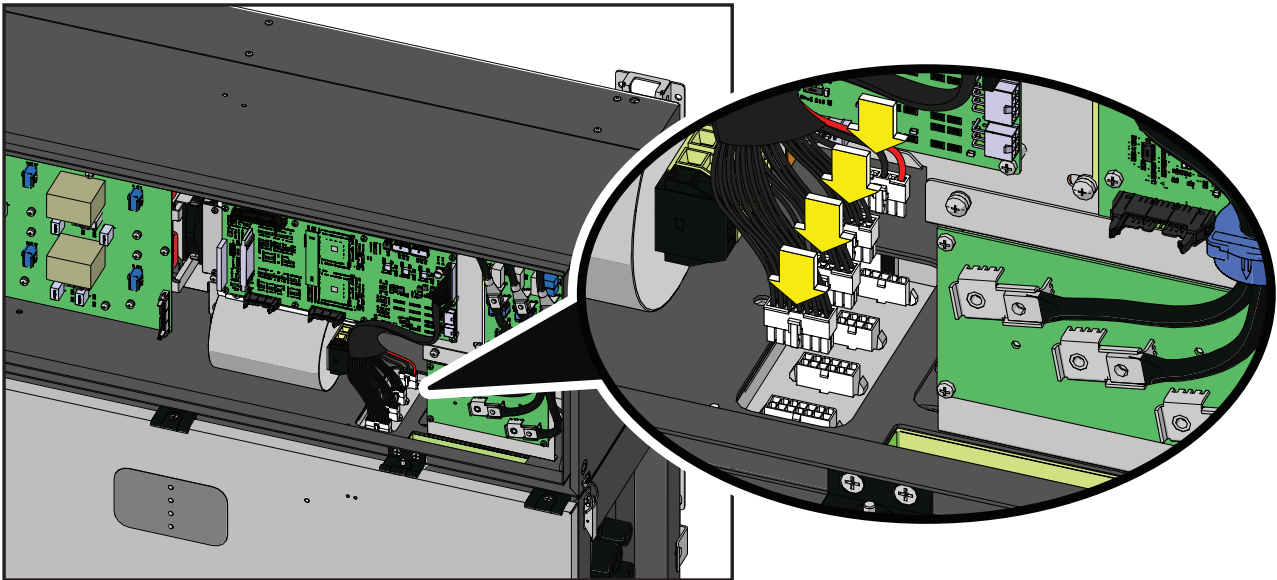

For connection to the network in South Africa. According to NRS097-2-1 requirements, at the end of installation it is mandatory to apply the label at the left (supplied with the inverter) near the power module regulatory label.

WARNING!		
NRS 097-2-1:2017 (South Africa)		
	Total [Ω]	X/R ratio
Reference Impedance	0.156	3.9
	I _{SC} [A]	S _{SC} [KVA] (three phase)
Fault Level	1475	1018

It is not intended to connect this inverter to a network with an higher Network Impedance.

Routing the cable to the inverter

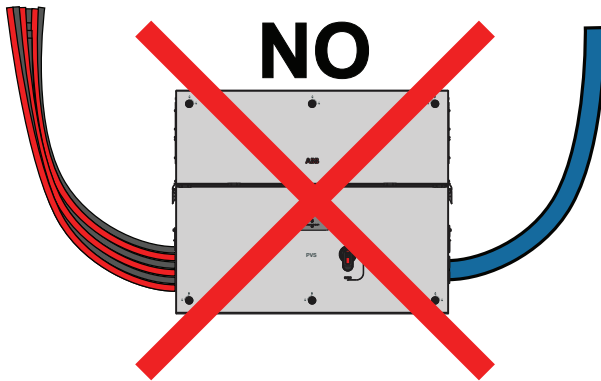

The cable routing have to be done in order to avoid water dripping to the AC panel (single-core or multi-core) cable glands, DC input quick fit connectors or to service cable glands.

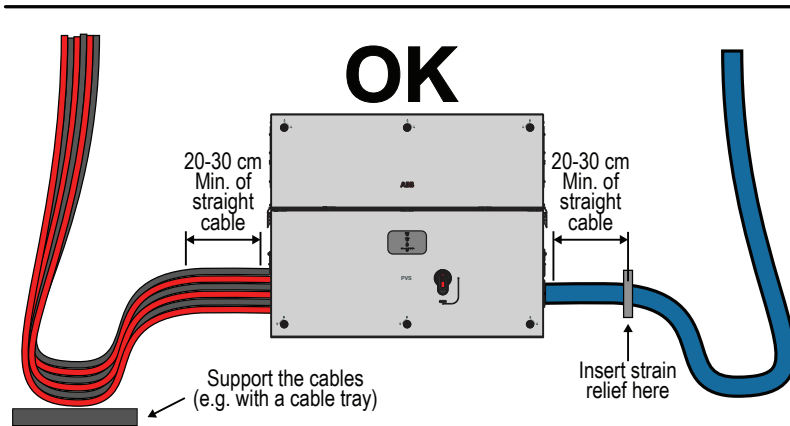

Especially when coming from the top, the cables must be routed in order to create a loop: in this way the water that flows on the cables will be drained.

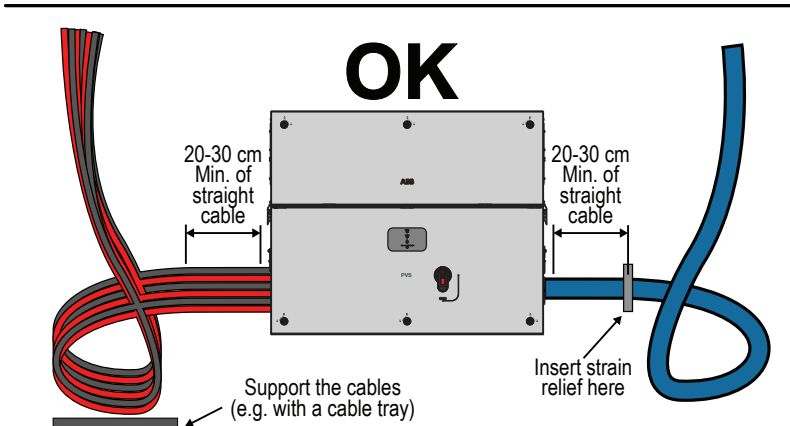

The AC and DC conductors must be anchored or supported in order to prevent loading and mechanical stress on the cable glands and quick fit connectors causing potential damage on the AC and the DC plates.

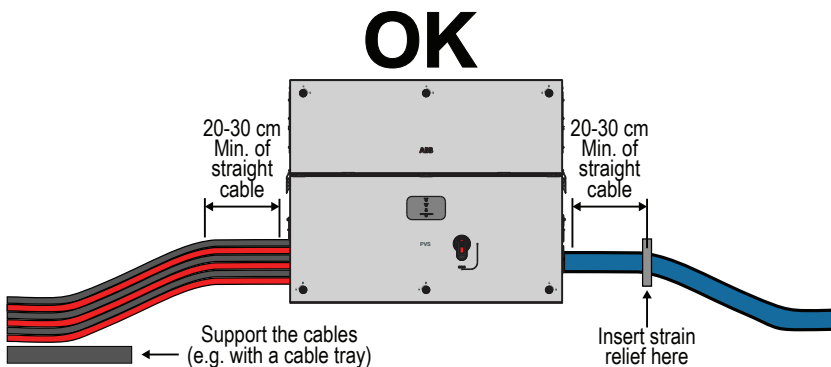

The side pictures are showing some example of incorrect and proper cable routing.



The previously installation examples shown only vertical installation but same rules have to be followed in case of horizontal installation of the inverter.

Grid output connection (AC side)

The inverter must be connected to a three-phase system with the center of the star connected to earth. To connect the inverter to the grid is possible to choose between the four-wire connection (3 phases + neutral) and the three-wire connection (3 phases).



In any case, the inverter's earth connection is mandatory.

Depending of the type of the AC panel it's possible to use single conductors cables or a multipolar cable:

- Single-core configuration ①① have 4xM40 cable glands for the "N" neutral, "R", "S", "T" phases and a M25 cable gland for the earth cable.
- Multi-core configuration ⑤⑥ (optional) have a M63 cable gland for the "N" neutral, "R", "S", "T" phases and a M25 cable gland for the earth cable.

The connections can also be made with the wiring box ②② detached from the power module ①① which can be connected later for commissioning.



When working with the wiring box ②② detached, (pay particular attention to outdoor installations) always protect the top of wiring box with proper IP66 protection covers (accessory of the PVS Installation KIT, to be ordered separately) on the housing. Refer to the dedicated chapter "Installation of IP66 protection covers for wiring box openings (long term installation)" for further information about the installation procedures.

Characteristics and sizing of the protective grounding cable

FIMER inverters must be earthed via the connection points marked with the protective earth symbol ⚡ and using a cable with an appropriate conductor cross-section for the maximum ground fault current that the generating system might experience. **In any case the minimum cross section of the ground conductor must be at least 1/2 of phase conductor cross section.**



Any failure of the inverter when it is not connected to earth through the appropriate connection point is not covered by the warranty.

The ground connection can be made through the Protective earth point (int.) ②⑤, Protective earth point (ext.) ①⑩ or both (if this is required by regulations in force in certain countries of installation).

The sizing of the ground cable depend on the choice of the protective earth point (internal ②⑤ or external ①⑩) where it will be connected:

	Protective earth point (int.) ②⑤	Protective earth point (ext.) ①⑩
Cable diameter range	10 - 17 mm (M25 cable gland)	-
Max. conductor cross section	95 mm ²	-
Cable lug dimensioning	for M10 Stud	for M8 Stud
	a = 10.5 mm (min) b = 40 mm (max)	a = 8.4 mm (min) b = all dimension accepted

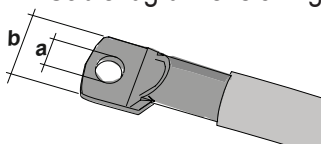

Characteristics and sizing of the line cable

The cross-section of the AC line conductor cables must be sized in order to prevent unwanted disconnections of the inverter from the grid due to high impedance of the line that connects the inverter to the power supply; If the impedance is too high it causes an increase in the AC voltage which, on reaching the limit set by the standards in the country of installation, causes the inverter to switch off.

The AC cables must be connected to AC connection busbar **21** using a cable lug (not supplied) of a suitable size for installation on the M10 screw used for securing the cable.

	Single core cable	Multi-core cable
Cable diameter range	19 - 28 mm	37 - 53 mm
Voltage/current rating	50 mm ²	
Cable lug dimensioning		

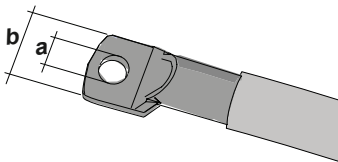

for M10 Stud

a = 10.5 mm (min)
b = 40 mm (max)



The AC connection busbars **21** are in copper tin-plated; therefore if aluminum cables are used, the correct coupling with the copper bars must be guaranteed by using appropriate bi-metallic cable lug.

Load protection switch (AC disconnect switch)

To protect the AC connection line of the inverter, an overcurrent protection device with the following features must be installed (these are the characteristic of a load protection switch referred to a single inverter installation):

	PVS-100-TL	PVS-120-TL
Type	Automatic circuit breaker with differential thermal-magnetic protection	
Voltage/current rating	400 Vac / min. 150 A (*)	480 Vac / min. 150 A (*)
Magnetic protection characteristic	Magnetic curve B/C	
Number of poles	3/4	

(*): please consider thermal and other derating when selecting the current rating of the protection equipment for your application.

Selection of differential protection downstream of the inverter

All FIMER string inverters marketed in Europe are equipped with a device for protection against ground faults in accordance with the safety standard IEC 62109-2, please refer to sections 4.8.2 and 4.8.3 of the Standard (equivalent to Standard DIN V VDE V 0126-1:2006, section 4.7). In particular, FIMER inverters are equipped with a redundancy on the reading of the ground leakage current sensitive to all components of both direct and alternating current. Measurement of the ground leakage current is carried out at the same time and independently by 2 different processors: it is sufficient for one of the two to detect an anomaly to trip the protection, with consequent disconnection from the grid and stopping of the conversion process.

There is an absolute threshold of **1.0 A** for PVS-100-TL or **1.2 A** for PVS-120-TL and of total leakage current AC+DC with protection tripping time at a max. of 300 msec.

Furthermore, there are another three tripping levels with thresholds respectively at **30 mA, 60 mA and 150 mA** to cover the “rapid” changes in fault current induced by accidental contact with leaking live parts. The max. tripping times are progressively shortened as the speed of change in the fault current increases and, starting from the 300 msec/max for the 30 mA change, they are shortened respectively to 150 msec and 40 msec for 60 mA and 150 mA changes.

For protection of the AC line, on the basis of the information above with regard to the differential protection integrated in **FIMER** inverters, **it is not necessary to install a type B ground fault switch.**

In case of installation of a residual current protection device must meet the following characteristics:

	PVS-100-TL	PVS-120-TL
Type	A / AC	
Sensibility	1.0 A	1.2 A



In accordance with article 712.413.1.1.1.2 of Section 712 of IEC Standard 64-8/7, we hereby declare that, because of their construction, FIMER inverters do not inject ground fault direct currents.



The use of an AC type circuit breaker with differential thermal magnetic protection with tripping current of 1.0 A for PVS-100-TL or 1.2 A for PVS-120-TL is advisable so as to prevent false tripping, due to the normal capacitive leakage current of photovoltaic modules.



In the case of systems which consist of several inverters connected to a single switch with differential protection it is recommended that a device is installed which allows the adjustment of the tripping value and the tripping time.

AC output cables connection



Before carrying out any operation, check that any external AC switch downstream to the inverter (grid side) are in OFF position applying LOTO procedure on it.

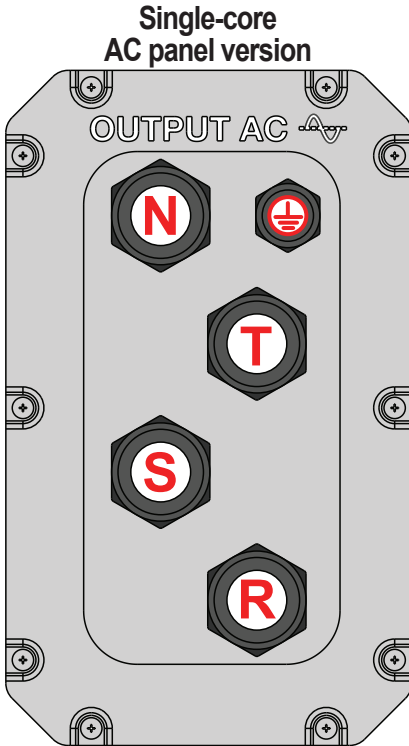

Routing of the AC cables inside the inverter must be carried out from the right side of the inverter.

Depending of the version of the AC panel installed on the inverter it will be necessary to route the AC output and ground cables into different ways:

- Single-core configuration 11 (default):

In this configuration the AC output and earth cables must be inserted into the proper cable glands, trying to follow a logical order based on the position of the internal connections:

R = Phase R (indicated with a label near the AC connection busbar 21)

S = Phase S (indicated with a label near the AC connection busbar 21)

T = Phase T (indicated with a label near the AC connection busbar 21)

N = Neutral (indicated with a label near the AC connection busbar 21)

The earth connection can be made using the Protective earth point (int.) 25 or Protective earth point (ext.) 10 or both (this is required by regulations in force in certain countries of installation).

⊕ = Earth (indicated with the protective earth symbol ⊕ near the protection earth connection point (int.) 25 or protection earth connection point (ext.) 10).

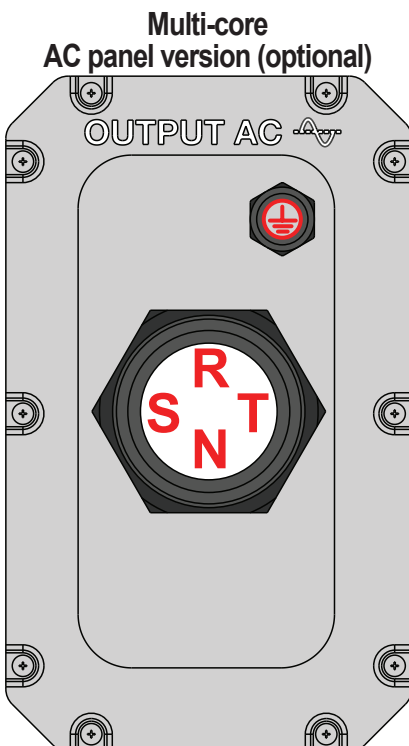

- Multi-core configuration 56 (optional):

one M63 cable gland for the “R”, “S”, “T” phases and for the “N” neutral cable and a M25 cable gland for the grounding cable.

This version of the AC panel 56 could be can be ordered separately.

Refer to “Kit of recommended spare parts” chapter for further information.

Follow the procedure below to route all the requested cables:

- Open the wiring box front cover 07.
- Remove the AC protective shield 27 by removing the M5 screw.

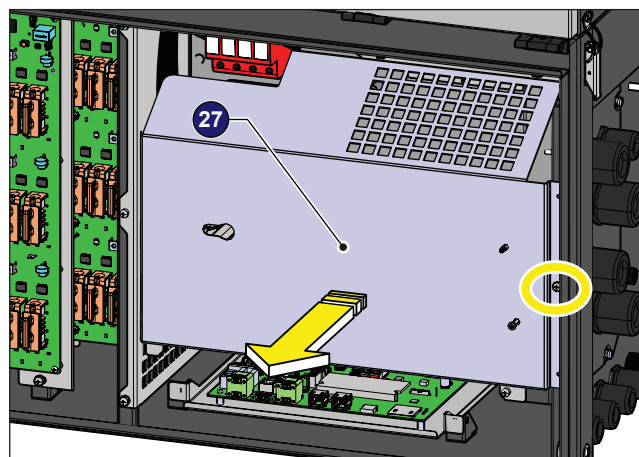

Depending on the ground connection method (internal 25 or external 10) follow the procedures described below:

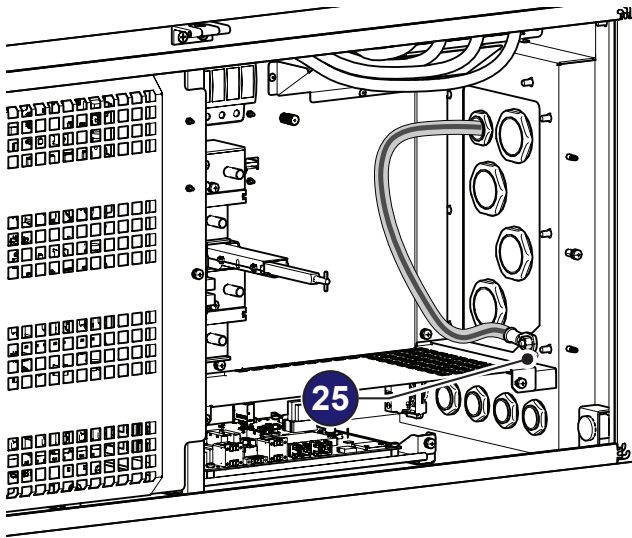

Internal earth connection

- Pass the protective earth cable through the proper cable gland on the AC panel.
- Fix the protective earth cable lug to the protection earth connection point (int.) 25 using the washers and bolt pre-installed on the M10 stud, as shown in the following diagram:

- 1 = cable lug
- 2 = flat washer
- 3 = spring washer
- 4 = M10 nut

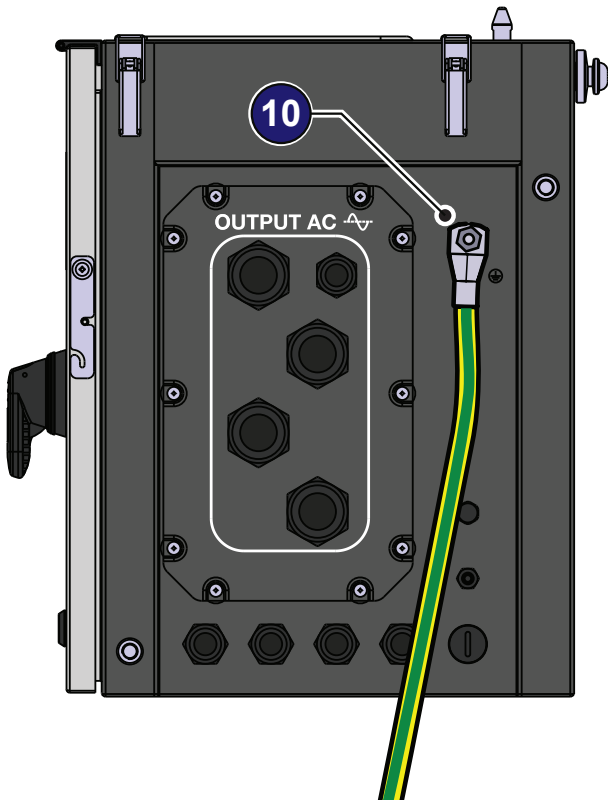
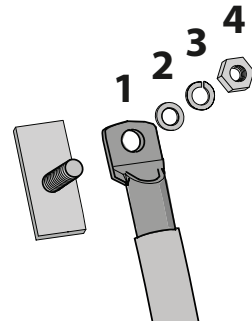

External ground connection

- Fix the protective earth cable lug to the protection earth connection point (ext.) 10 using the washers and bolt pre-installed on the M8 stud, as shown in the following diagram:

- 1 = cable lug
- 2 = flat washer
- 3 = spring washer
- 4 = M8 nut

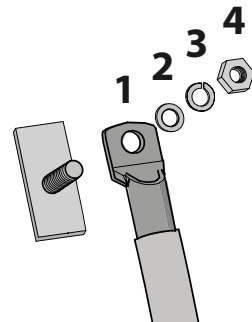

The cable lug must be installed with a minimum tightening torque of 21Nm.



Before connecting the inverter to AC or DC sources use a suitable multimeter to test the conductivity of the earth connections between the protection earth connection point (ext.) 10 and a handles thread 04 on the housing of power module.

- Pass the phases cables through the cable glands on the AC panel 11.

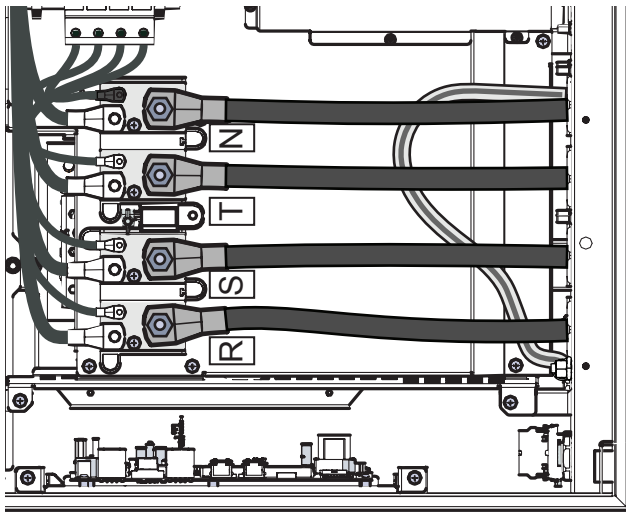

- Fix the phases and neutral (if required) cable lugs to the AC connection busbars 21, paying attention to the correspondence of the phases with the labels, using the washers and the M10 nuts pre-installed on the busbar as shown in the following diagram:

- 1 = cable lug
- 2 = flat washer
- 3 = spring washer
- 4 = M10 nut

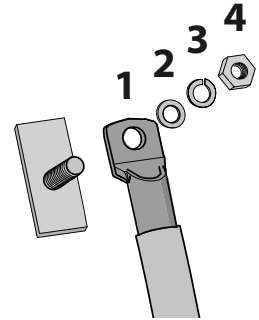

The minimum recommended cross section for the phases conductors is 70 mm².

The cable lugs must be installed with a minimum tightening torque of 25Nm.

- Check the tightness of the AC cable glands at the end of the installation.



Make sure the cable glands are properly sealed to ensure to keep IP65 protection degree.

Operations preliminary to the connection of the PV generator



In order to safely perform the preliminary operations before the connection to the PV generator, the connection of the ground protection cable to the wiring box is mandatory.

Checking of leakage to ground of the photovoltaic generator

Measure the voltage present between positive and negative pole of each string with respect to ground.

If a voltage is measured between an input pole and ground, it may be that there is a low insulation resistance of the photovoltaic generator and the installer will have to carry out a check to solve the problem.



Do not connect the strings if a leakage to ground has been detected, as the inverter might not connect to the grid.



Refer to “Verification of ground leakage” chapter on this manual to know how to verify the leakage to ground of the photovoltaic generator.

Checking of strings voltage

Measure the voltage present between positive and negative pole of each string.

If the open circuit voltage of the string is near the maximum value accepted by the inverter, consider that low ambient temperatures cause an increase in the string voltage (different according to the photovoltaic module used). In this case it is necessary to carry out a check of the sizing of the system and/or a check on the connections of the modules of the system (e.g.: number of modules in series higher than the design number).



Input voltages higher than the maximum value accepted by the inverter (see technical data table) may occur the damage of the inverter.

Access the negative side string fuses board (-SX2, SY2 wiring box version only)



Some inverter parts may be subject to voltages that could be hazardous for the operator. Before performing any work on the inverter, refer to “Inverter total de-energization and safe access” chapter on this manual to know all the necessary step to safely operate on the inverter.

The fuses boards are installed on tilting plates: the positive side string fuses board **19** can be tilted to access to the negative side string fuses board **20** (-SX2, SY2 wiring box version only).

In order to access the negative side string fuses board **20**, the positive string fuses plate **19** have to be opened as follow:

- Remove the screw and the DC protective shield **60** (picture **A**)
- Remove the two M5 screws from the positive string fuses plate **19**.
- Tilt the positive string fuses plate **19**.
- Use a screwdriver, to lock the positive string fuses plate (picture **B**)

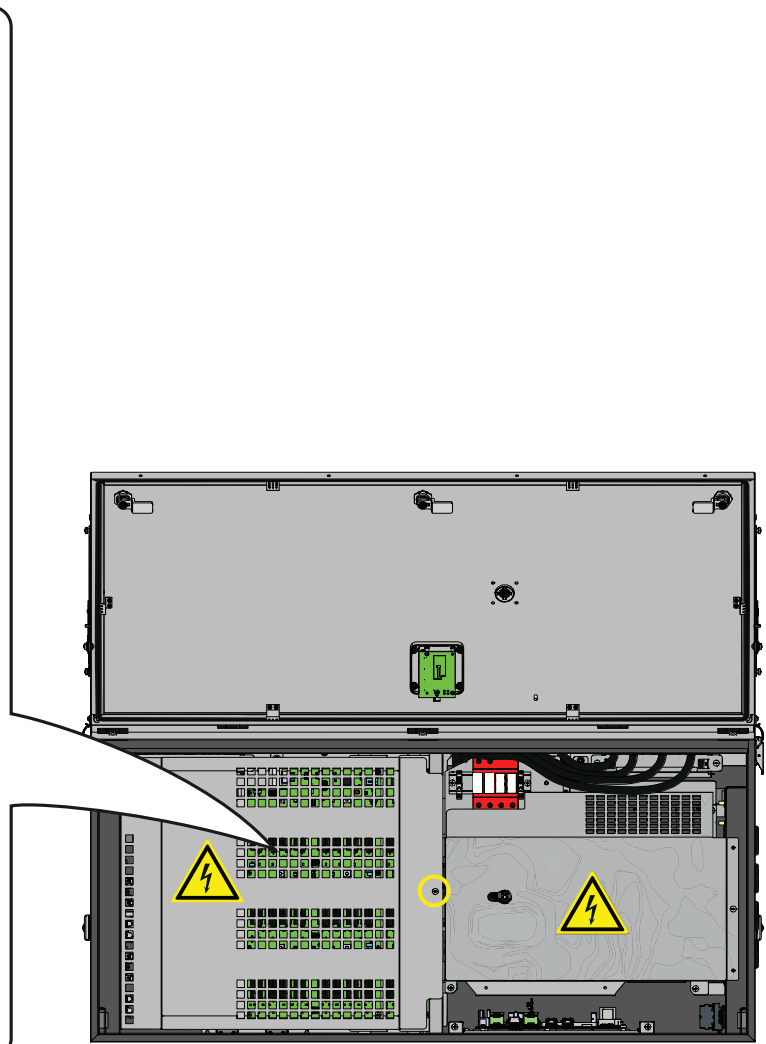
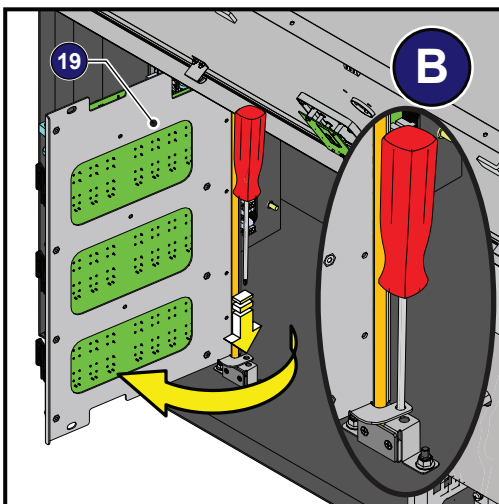
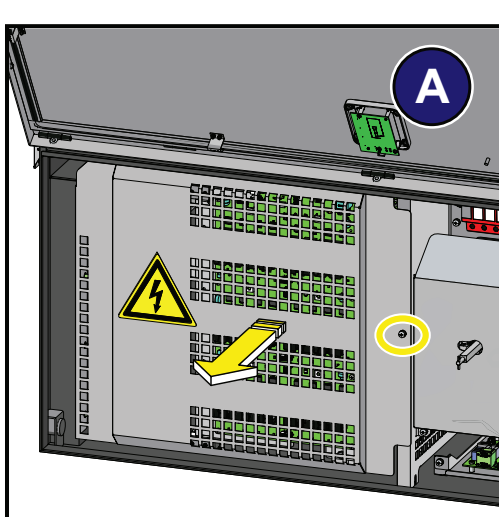

Checking the correct polarity of the strings and fuses installation



This activity is allowed ONLY with the appropriate PPE for carrying out this check (overall resistant to electric arc, dielectric helmet with visor, insulating gloves class 0, Protective overglove in leather EN420 – EN388, Safety shoes).

The reverse polarity can cause severe damage.

Depending on the wiring box ⁰² version installed on the inverter there are one or two boards for the string fuses:

- **SX, SY version:** contains only positive side string fuses board ¹⁹ and has 24 string fuses (1 for each string) that are supplied and have to be installed.

- **SX2, SY2 version:** contains both positive side string fuses board ¹⁹ and negative side string fuses board ²⁰ that totally have 48 string fuses (2 for each string). Fuses on the negative side string fuses board ²⁰ are already fitted while the fuses on the positive side string fuses board ¹⁹ are supplied and have to be installed.

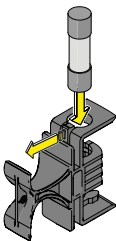
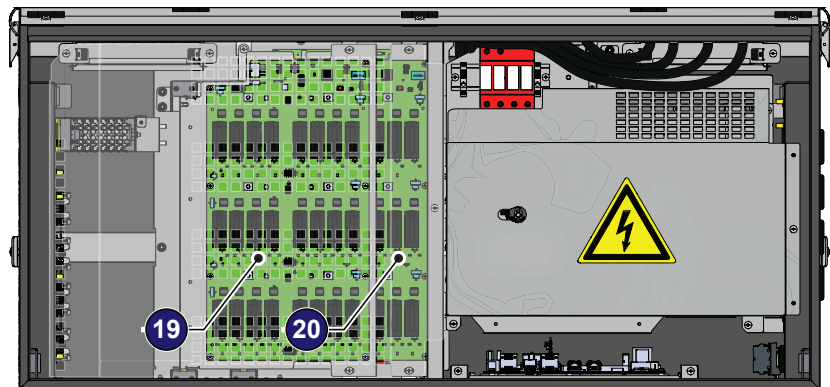

The string fuses are installed inside special safety positioners that allow easy installation/removal, as well as providing protection from involuntary contact while the inverter is being installed.

Each fuse is associated with a green LED that could be used to check the correct polarity of the strings.

Procedure for checking the correct polarity of the strings

1. Check for the absence of installed fuses on the positive side string fuses board ¹⁹ - if present remove it!
2. Turn the DC disconnect switches ¹⁵ to OFF.
3. Connect the strings (refer to "Input connection to PV generator (DC side)" chapter) and check that the GREEN LED corresponding to each positive fuse activates. The string will turn out to be inverted if the green LED is OFF or, in some circumstances, faintly ON. Check the strings one by one so to safely check which strings are inverted.
4. After all the input strings have been checked, remove all connected strings and check that all LEDs will switch OFF.
5. Install the fuses (supplied) on the string fuses board ¹⁹ with the supplied fuse holders.
6. Connect all input strings.

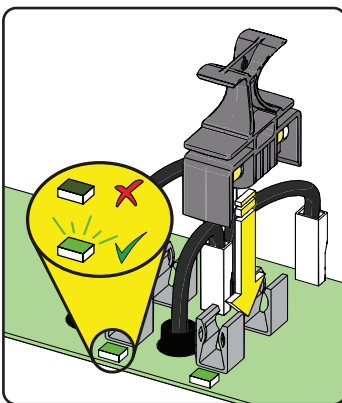

Input connection to PV generator (DC side)

After having carried out preliminary checks and therefore having verified that there are no problems in the photovoltaic system, you may connect the inputs to the inverter.



Comply with the maximum input current relating to the quick-fit connectors as indicated in the technical data.



Polarity inversion can cause serious damage. Check polarity before connecting each string!



The installation must be performed by qualified installers and/or licensed electricians in accordance with the existing regulations in the country of installation and in accordance of all safety rules for performing electrical works. These activity is allowed ONLY with the appropriate PPE for carrying out this check (overall resistant to electric arc, dielectric helmet with visor, insulating gloves class 0, Protective overglove in leather EN420 – EN388 , Safety shoes).



Caution! The inverters referred to in this document are TRANSFORMERLESS. This type requires the use of insulated photovoltaic panels (IEC61730 Class A Rating) and the need to keep the photovoltaic generator floating with respect to ground: no terminal of the generator must be connected to ground.

For the string connections it is necessary to use the quick fit connectors **16** (usually Weidmüller PV-Stick or WM4, MultiContact MC4 and Amphe-nol H4) located on the left side of the wiring box **02**.

Refer to the document “String inverter – Product Manual appendix” available at www.fimer.com to know the brand and the model of the quick fit connector. Depending on the model of the connector of the own inverter, it is necessary to use the same model and the respective counterpart (check the compliant counterpart on the website of the manufacturer or in FIMER)



Using corresponding parts that are not compliant with the quick fit connector models on the inverter could cause serious damage to the unit and lead to invalidation of the warranty.

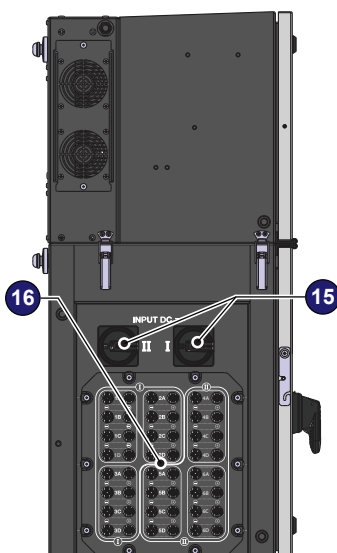

The input connectors are divided into 6 groups (one group for each input channel) consisting of 4 pairs of quick fit connectors.



The connection in parallel of the strings (array composition) could be made upstream of the input connectors marked with “B” and/or “C” using a proper Y quick fit connector adapters: in this case the input fuses will have to be replaced with a suitable size for the paralleled strings.

Connect all the strings required by the system, always checking the seal of the connectors.

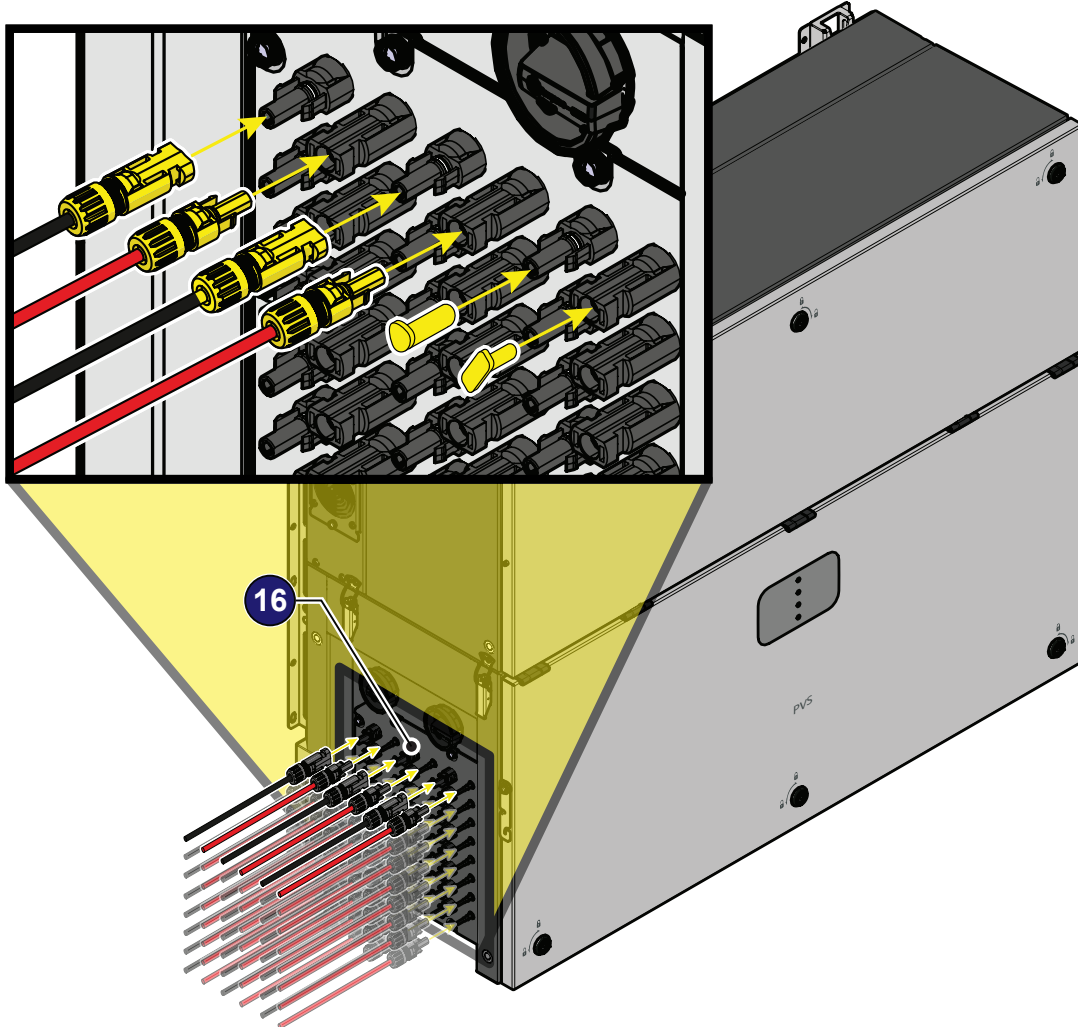

If any string inputs are not required, you must ensure that covers are installed to the connectors, and install any which are missing. This is necessary both for the inverter seal, and to avoid damage to the free connector which may be used at a later time.

The connections can also be made with the wiring box 02 detached from the power module 01 that can be connected later for commissioning. When working with the wiring box 02 detached, pay particular attention to:



- presence of ground connection
- The top of wiring box must always be protected in outdoor installations with proper IP66 protection covers (optional accessory content in PVS Installation kit, to be ordered separately). Refer to the dedicated chapter “Installation of IP66 protection covers for wiring box openings (long term installation)” for further information about the installation procedures.

Installation procedure for quick-fit connectors

In the inverter models, where the quick-fit connectors are used, is possible to find one of the following four types:

- Weidmüller PV-Stick
- Weidmüller WM4
- MultiContact MC4
- Amphenol H4.

Please refer to the document “*String inverters – Product manual appendix*” available at www.fimer.com for information on the quick-fit connector brand and model used in the inverter.

The model of connectors installed on your inverter must be matched by the same model of the respective corresponding parts to be used (checking the conforming corresponding part on the manufacturer's website or with FIMER).



Using corresponding parts that are not compliant with the quick-fit connector models on the inverter could cause serious damage to the unit and lead to invalidation of the warranty.



CAUTION: To avoid damage to the equipment, when attaching cables, pay particular attention to polarity.

1. WEIDMÜLLER PV-Stick quick-fit connectors

Installation of Weidmüller PV-Stick connectors does not require any special tooling.

- Strip the cable to which you want to apply the connector (after verifying that it complies with the connector limits).

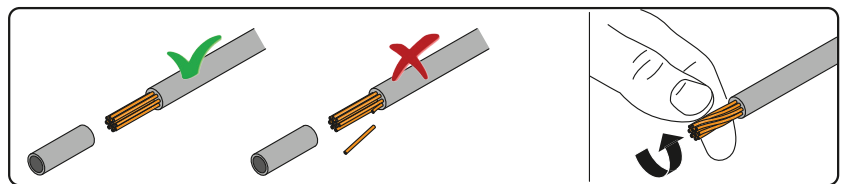
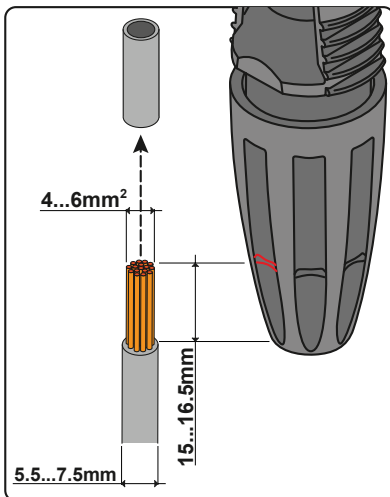

- Insert the wire into the connector until you hear a locking "click".

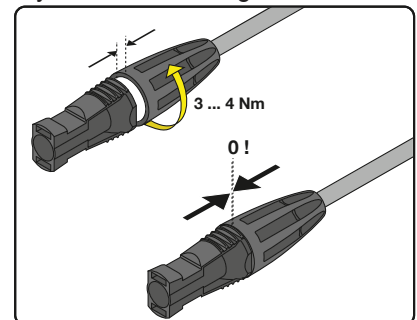
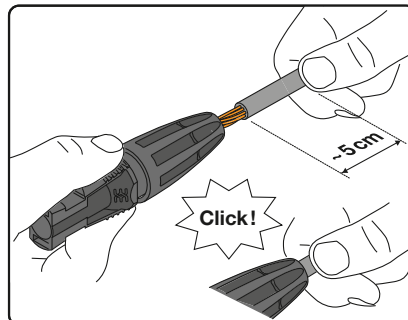

- Tighten the knurled ring nut for optimal clamping.

2. WEIDMÜLLER WM4 quick-fit connectors

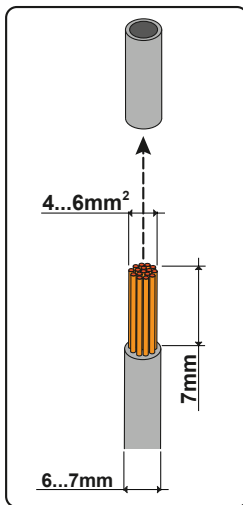

Installation of Weidmüller WM4 connectors requires crimping to be carried out with suitable equipment.

- Strip the cable to which you want to apply the connector (after verifying that it complies with the connector limits).

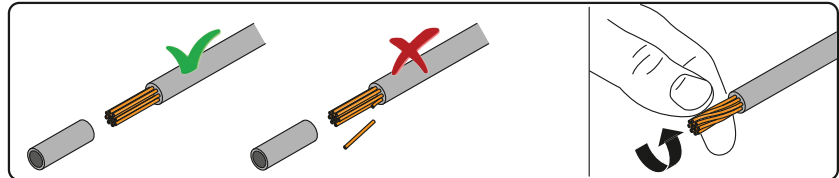

- Apply the terminal to the conductor using the designated pliers.

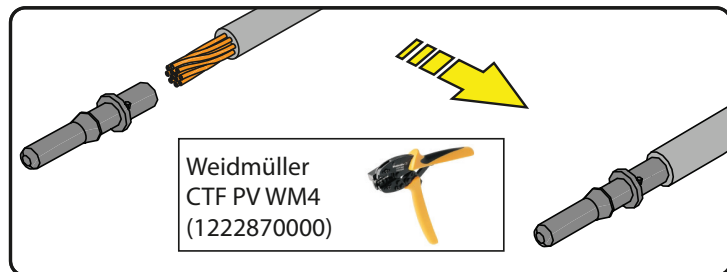

- Insert the cable with the terminal into the interior of the connector, until you hear the click indicating that the terminal is locked inside the connector.

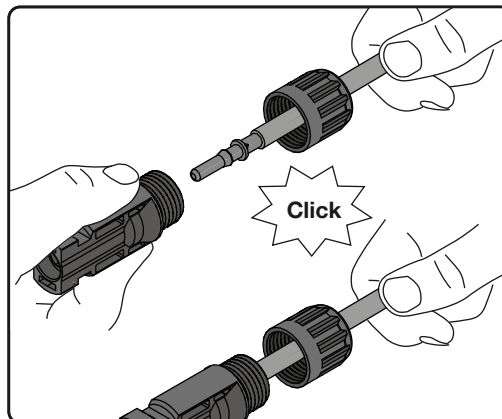

- Firmly tighten the cable gland using the relevant tool to finish the operation.

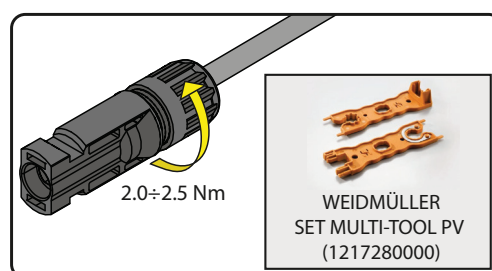

3. MULTICONTACT MC4 quick-fit connectors

Installation of Multicontact MC4 connectors requires crimping to be carried out with suitable equipment.

- Strip the cable to which you want to apply the connector (after verifying that it complies with the connector limits).

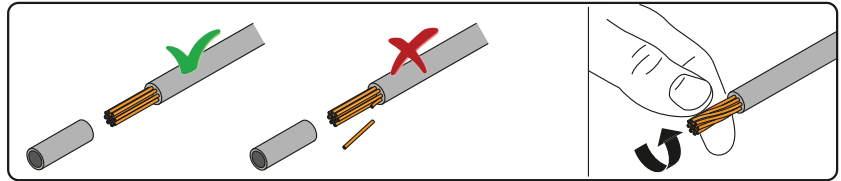
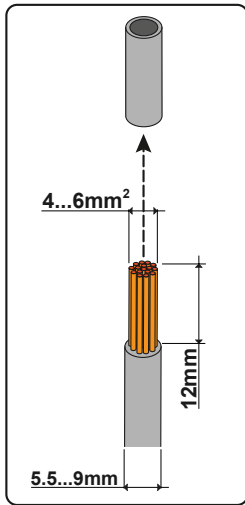

- Apply the terminal to the conductor using the designated pliers.

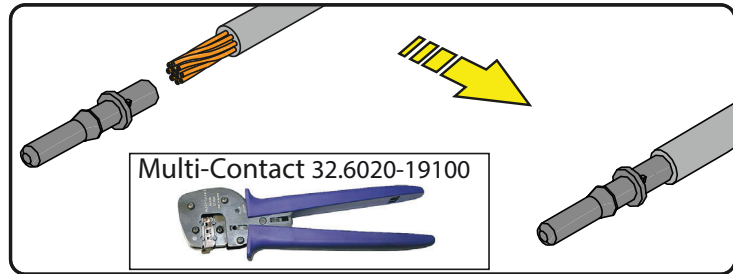

- Insert the cable with the terminal into the interior of the connector, until you hear the click indicating that the terminal is locked inside the connector.

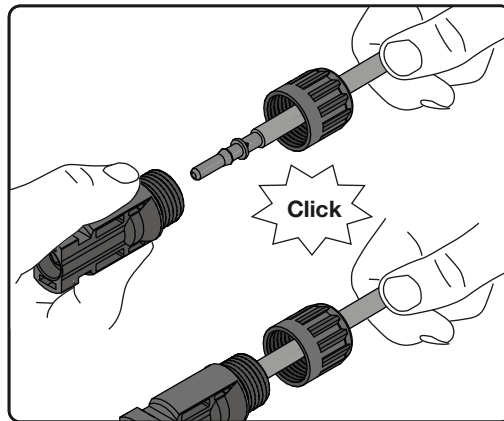

- Firmly tighten the cable gland using the relevant tool to finish the operation.

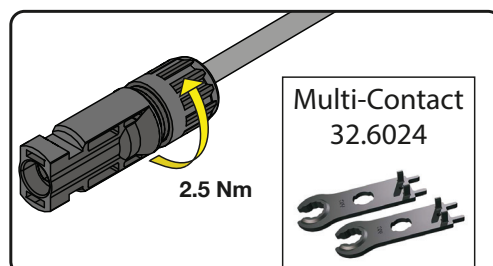

4. AMPHENOL H4 quick-fit connectors

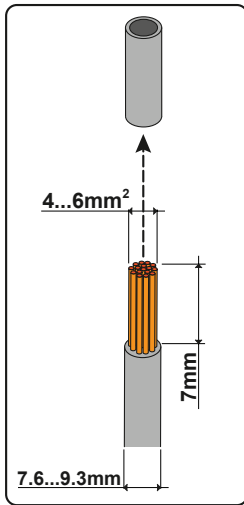

Installation of Amphenol H4 connectors requires crimping to be carried out with suitable equipment.

- Strip the cable to which you want to apply the connector (after verifying that it complies with the connector limits).

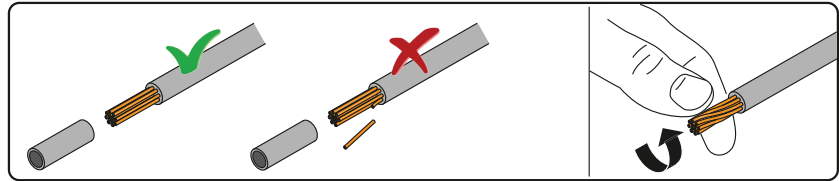

- Apply the terminal to the conductor using the designated pliers.

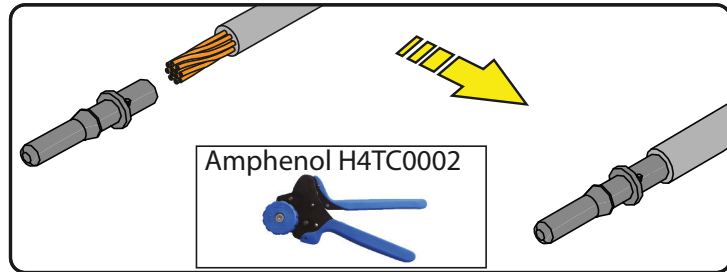

- Insert the cable with the terminal into the interior of the connector, until you hear the click indicating that the terminal is locked inside the connector.

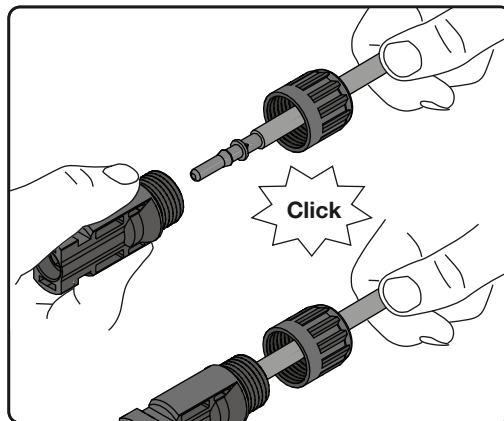

- Firmly tighten the cable gland using the relevant tool to finish the operation.

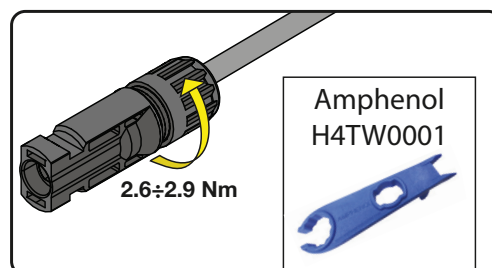

String protection fuses

Sizing of fuses

The correct sizing of the 19 positive side and 20 negative side (-SX2, SY2 wiring box model) string fuses to be used to protect from “return currents” is very important because it can considerably limit the risk of fire and damage to the PV generator.

A “return current” can be generated in the event of a fault and relevant short-circuit at the ends of one or more PV modules of the system; this condition can cause all the current supplied by the strings not involved in the fault, but connected to the same input channel, to pass through the faulty string.

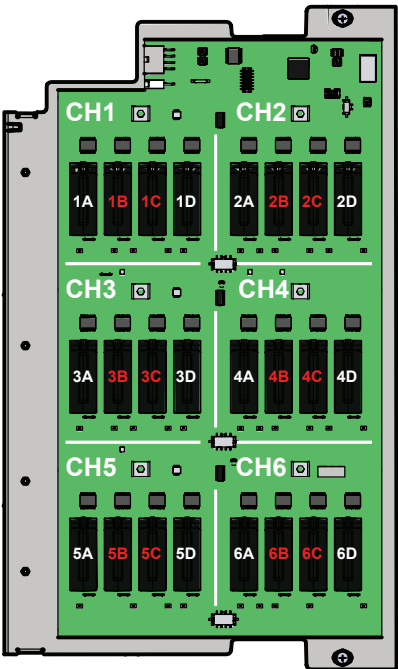
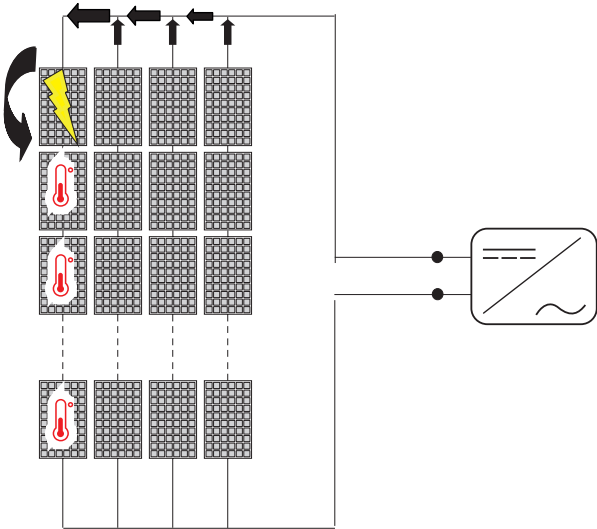

For input connectors marked with “A” and “D” you must directly connect the individual strings coming into the inverter (do not make field switchboards for parallel strings). This is because the positive side 19 and negative side 20 string fuses, situated on each input, are not rated to take strings in parallel (array).

This operation could damage the fuses and consequently could cause malfunctioning of the inverter.

The connection in parallel of the strings (array composition) could be made upstream of the input connectors marked with “B” and/or “C” using a proper Y quick fit connector adapters: in this case the input fuses will have to be replaced with a suitable size for the paralleled strings.

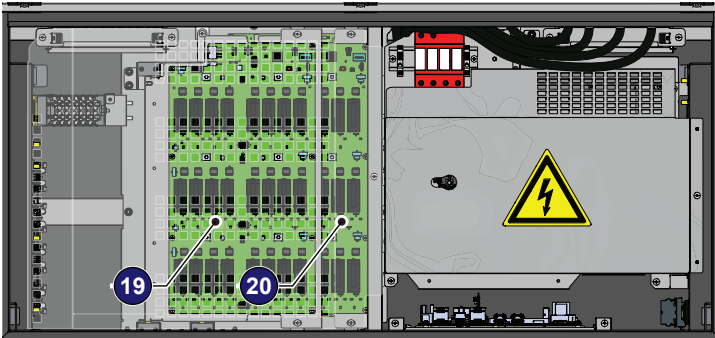

The sizing of the string fuses must be made taking into account the 2 following conditions:

1. The nominal current of the fuse (I_{rated}) must not exceed the maximum rating of the fuse to be used in series on the strings (maximum series fuse rating), indicated in the technical data of the PV modules in compliance with standard EC 61730-2:

$$I_{rated} < \text{Maximum series fuse rating}$$

2. The fuse rating (I_{rated}) must be determined based on the string current and on the sizing guidelines provided by the manufacturer to avoid untimely tripping. As a general guideline, based on the photovoltaic modules' short circuit current (I_{sc}), it is possible to calculate the rating of the fuse with the following formula:

$$I_{rated} > (1.4 \approx 1.5) * I_{sc}$$

Fuses must be chosen among the standard commercially available ratings, selecting the value that is closest to the obtained result.

The fuse selected with the calculation described previously takes into consideration derating factors and corrections such as:

- increase in the effective irradiation of the installation area
- Increase in the I_{sc} on the basis of the high temperature of the PV module
- Thermal derating of the fuse
- Maximum return current of the PV modules installed

FIMER can supply fuse kits of different values

Code	Description	Quantity
KIT 24 FUSES 12A	Kit of 12A fuses	24
KIT 24 FUSES 15A	Kit of 15A fuses	24
KIT 24 FUSES 20A	Kit of 20A fuses	24
KIT 24 FUSES 30A	Kit of 30A fuses	24



For effective calculation taking real installation conditions into account, refer to the documents supplied by the protection fuse manufacturer.

Communication and control board

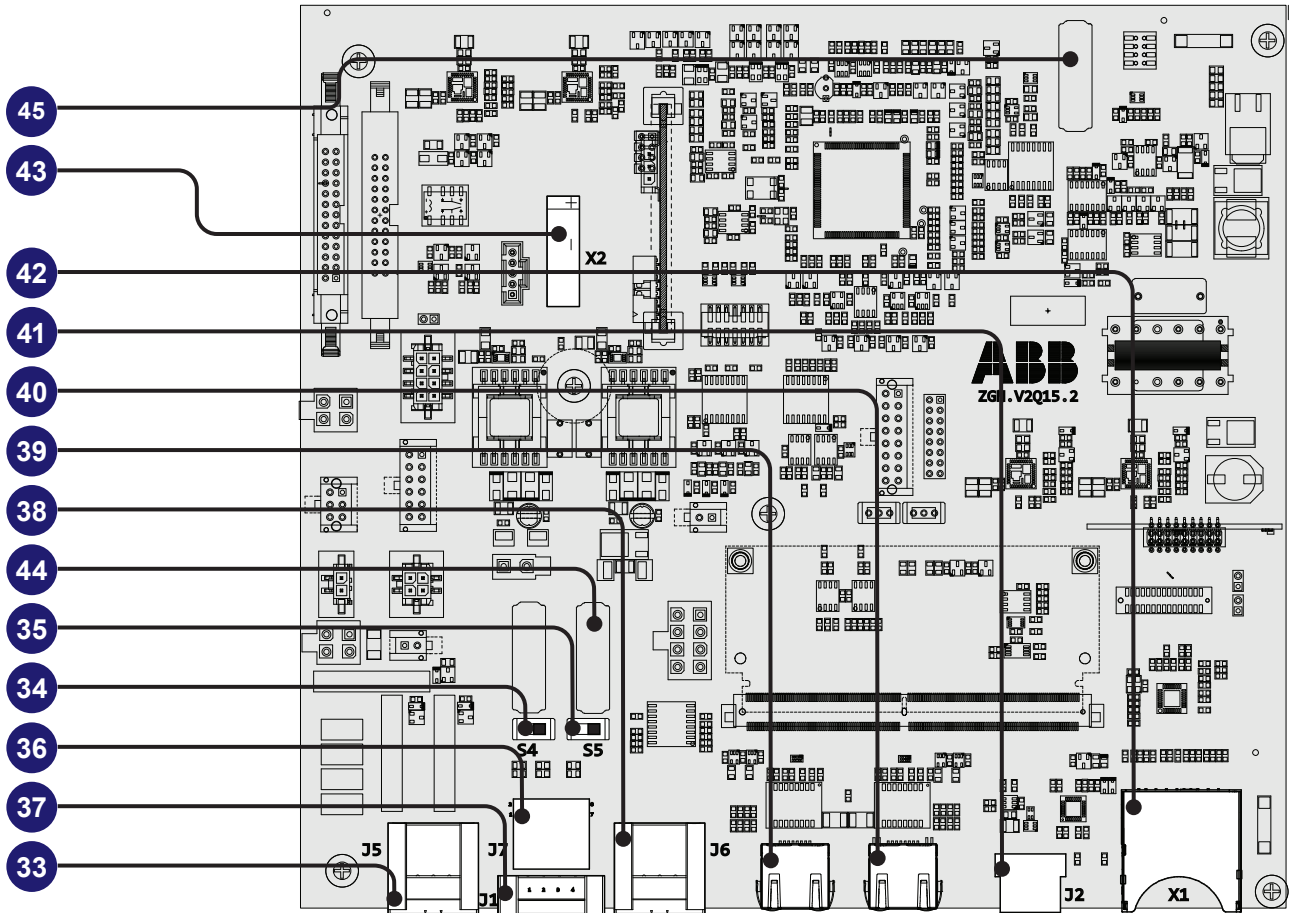

Code	Reference	Description of the communication and control board 09
J5	33	Multifunction relay connector (ALARM terminal block)
S4	34	RS-485 FIMER service 120Ohm termination resistance switch (FIMER service only)
S5	35	RS-485 line 120Ohm termination resistance switch
J7	36	RS-485 connector (RJ45) (FIMER Service only) (*)
J1	37	Remote ON/OFF terminal block (*)
J6	38	RS-485 line terminal block
-	39	Ethernet connector 2 (RJ45)
-	40	Ethernet connector 1 (RJ45)
J2	41	USB connector
X1	42	SD card slot
X2	43	CR2032 coin battery
J13	44	RS485 line communication board
J33	45	Memory card

(*) The RS-485 connector (RJ45) (FIMER Service only) 36 and the signal R1 on the Remote ON/OFF terminal block 37 are used to bring the signals on the external connector RS-485&Rem.ON/OFF 57.

Connections to the communication and control board

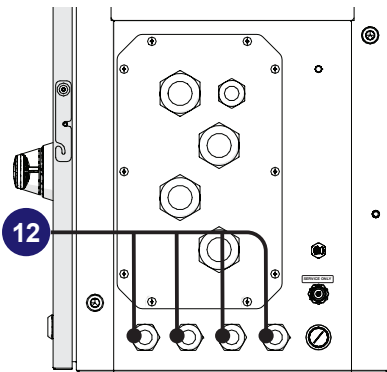

The communication and control signals are connected to the communication and control board **28** inside the wiring box **02** or directly to the connectors on the external of the inverter. In particular, on the right side of the wiring box **02**, there are four M25 cable glands **12** that can be used to reach the terminals / connectors on the communication and control board. Each cable gland accepts a single cable from 10 mm to 17 mm diameter.

As an alternative to each cable gland internal gasket the two-hole gasket (supplied) could be installed:

The two-hole gasket accepts two cables with a diameter of 6mm; if a seal hole is not to be used, it is necessary to install a plug (supplied plastic cylinder) to ensure the inverter's sealing.

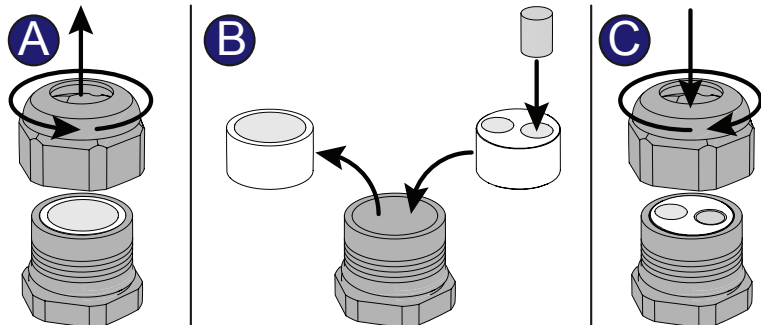

*Please ensure that all unused cable glands **12** are properly sealed by the IP65 plastic cap.*

To connect the signal and communication wirings, the communication and control board **28** have to be extracted by removing the two M5 screws, as shown in the picture below:

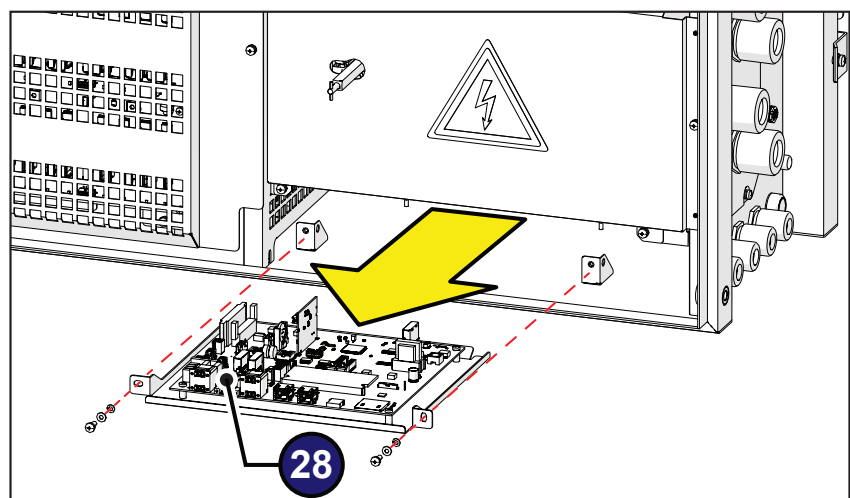

After the connections has been made, re-insert the communication and control board **28** in the own board tray and fasten the two M5 screws previously removed.

Check the tightness of the signal cable glands **13** at the end of wiring operations.

Ethernet connection

The ethernet connection allows a direct data transfer to the FIMER server for monitoring purpose. When the inverter will be powered on, network parameters are automatically set and the inverter starts transmitting telemetry data to the Aurora Vision® CLOUD platform.

The connection of the ethernet communication cable must be made on the specific connectors **39** **40** located on the Communication and control board **28**.

If the inverters of the plant need to be connected in daisy chain or ring configuration use both connectors.

The cable should be compliant to the following specification:

- Cable type: Patch or Cross type, 100BaseTx, CAT5e (or higher). For outdoor application and/or in presence of strong electromagnetic sources it is advisable to use shielded cables with metallic shielded RJ-45 plug.
- UV-resistant if used outdoors
- Type of plug: metallic shielded RJ45
- The maximum length that can reach these cables is 100 meters, and it is always advisable not to let them pass by the power cords to avoid interference with data transmission.
- Maximum inverters number connected over one single daisy chain is 40

For outdoor application and/or in presence of adverse weather/strong electromagnetic events it is advisable to use additional overvoltage protective devices.

In order to avoid earth loop (that could create communication issues) the shield of any Ethernet cable must be connected to the RJ45 plug in only one side, the other side of the shield should be leaved floating. This could be guaranteed by crimping the shield or the screen of the ethernet cable to the RJ45 connectors only at one end of each cables.

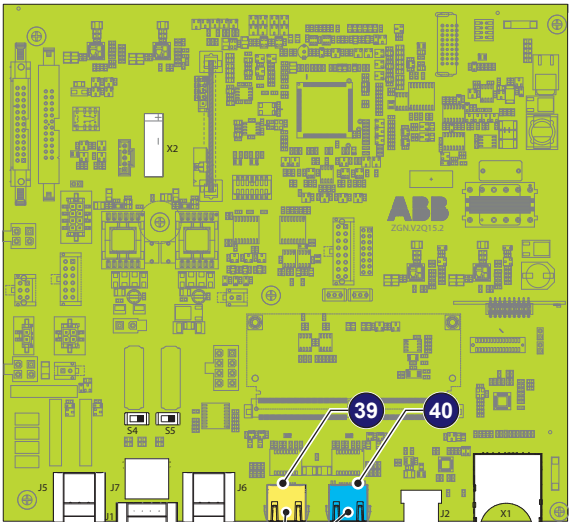

The two RJ45 connectors LAN1 and LAN2 are equivalent to each other and can be used interchangeably for the input or for the output of the line in realising the connection of the inverters.

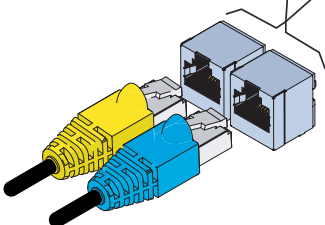

000979AG-F

Three topologies of ethernet connection to the router are available:

The ring configuration is the preferable way to connect the units in order to allow reaching inverters in case of single inverter fault.



In case inverters are connected to the networking switch with a ring topology is recommended to enable SPT protocol on the switch (Spanning Tree Protocol SPT (IEEE 802.1D) is enabled by default on inverters).

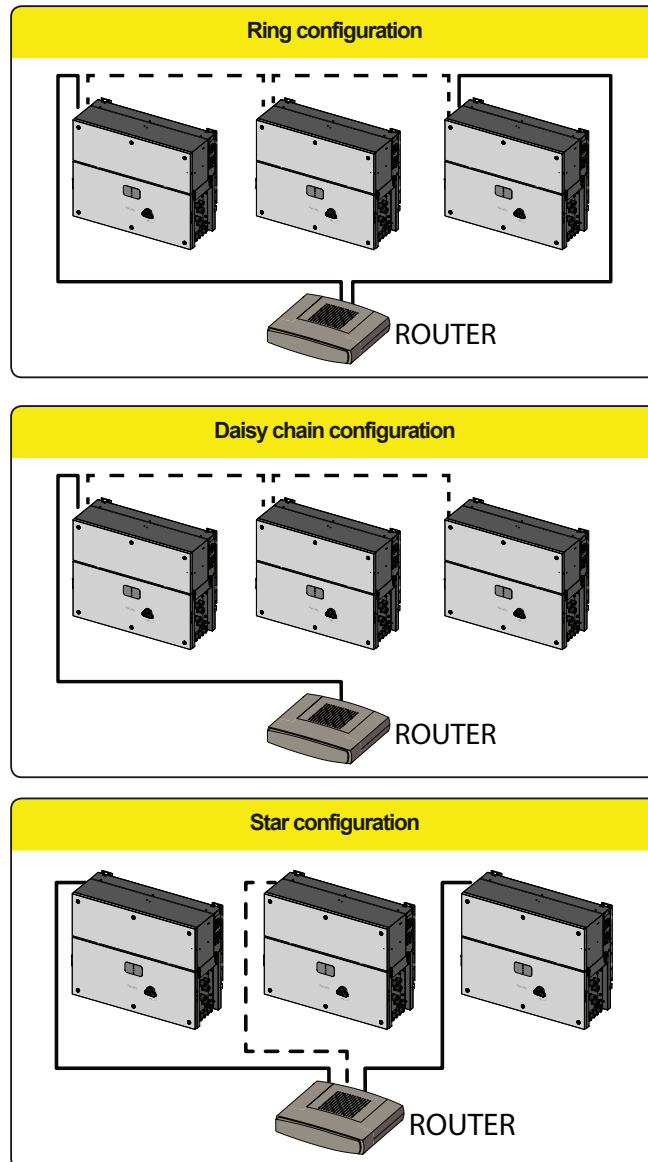

On each configuration of connection the maximum length of the cable must be 100m maximum between inverter – inverter and inverter – switch.

For further information on the Ethernet connection refer to the Local Area Network standard IEEE802.3.



Please refer to Aurora Vision documents available on FIMER website for further information how to get an Aurora Vision account for remotely monitoring and managing the installed solar assets.



No initial setup is required to start data transmission to Aurora Vision. Internet connection is required to use all the Aurora Vision remote functionalities.

Serial communication connection (RS485 - Slave mode)



Please note that automatic settings of network parameters at turning on, embedded logging capability, automatic logger-free transferring of data to Aurora Vision Cloud and remote firmware update are provided over TCP/IP (Ethernet and/or Wi-fi) bus only.



The use of the inverters over the RS485 line is recommended in case of monitoring and controlling by using third party RS485 control systems.

By default the RS485 port 38 is set as Slave mode. In case the port was set as “Master mode” it must be configured through the integrated Web User Interface (refer to chapter “Web User Interface”) to use the RS485 as a serial communication lines.

RS485 line supports Modbus/RTU SUNSPEC compliant Modbus protocol.

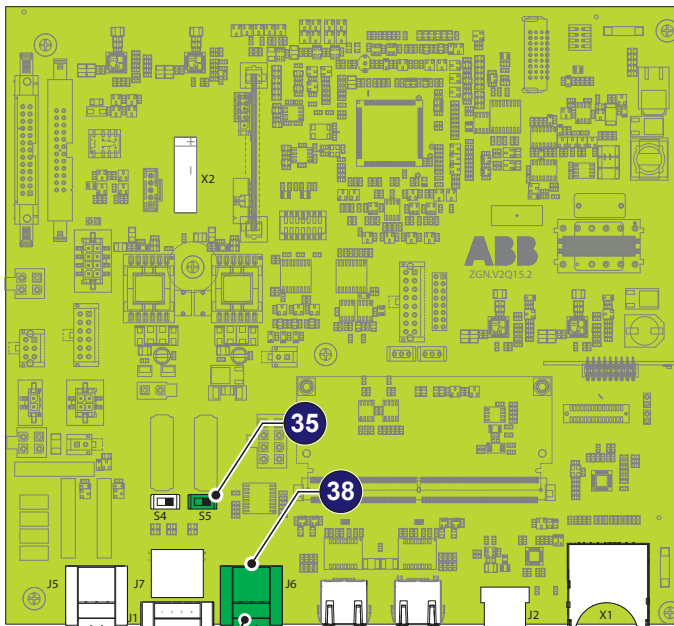

- Connection of the R485 communication line conductors is made using the terminal block connectors 38 (485+, 485- and RTN).

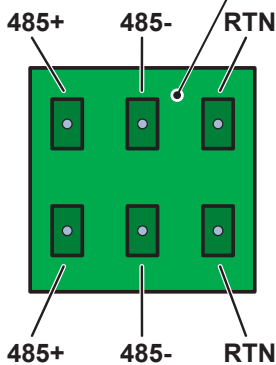

For long distance connections, the connection on terminal connector is preferable using a shielded twisted pair cable with characteristic impedance of $Z_0=120$ Ohm like the one shown on the following table:

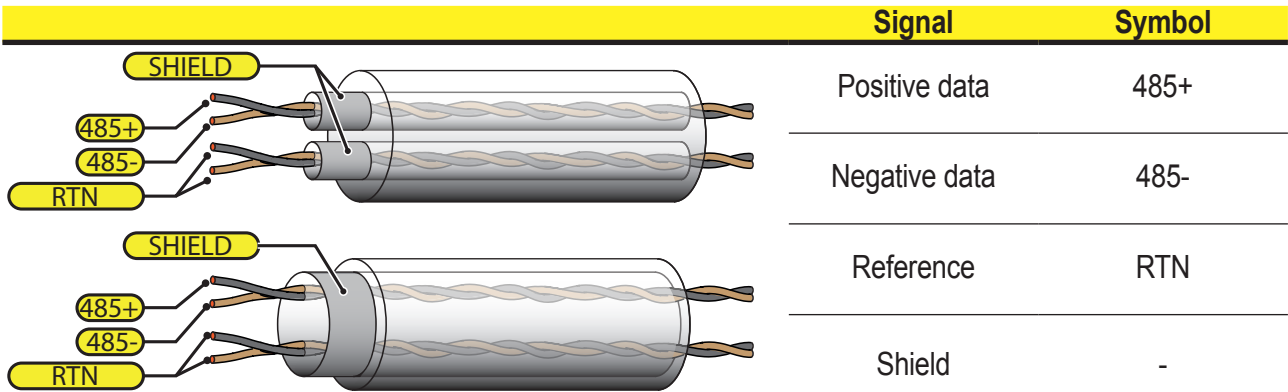

Shield continuity must be provided along the communication line and must be grounded in a single point.

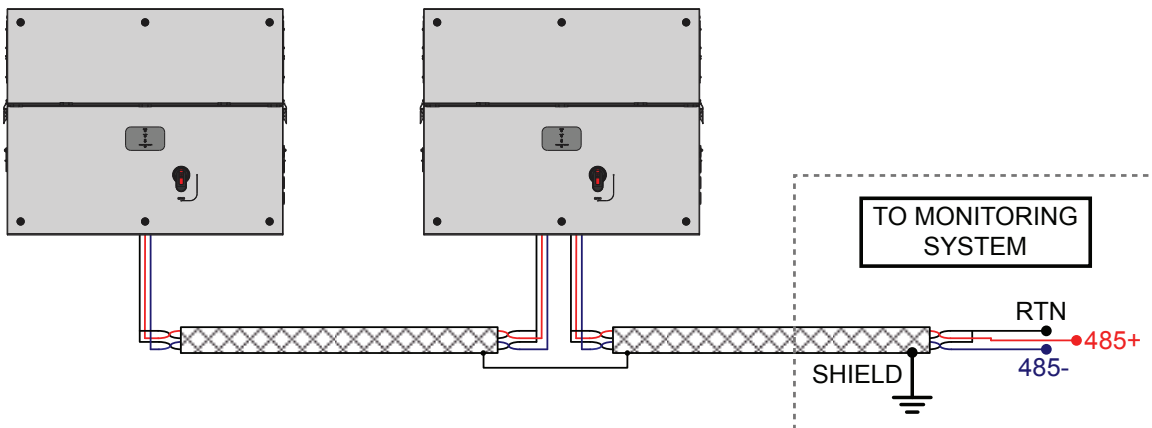

The RS485 line can be used to set up a line of communication which, when connected to a monitoring device, enables the operation of the photovoltaic system to be kept under control. Depending on the device used monitoring can be local or remote.



For information on installation, compatibility and use, please refer to the specific documentation on the accessory components.

Connect all the units of the RS485 chain in accordance with the daisy-chain model observing the correspondence between the signals, and activate the termination resistance of the communication line in the final element of the chain by switching the 35 switch in the ON position.

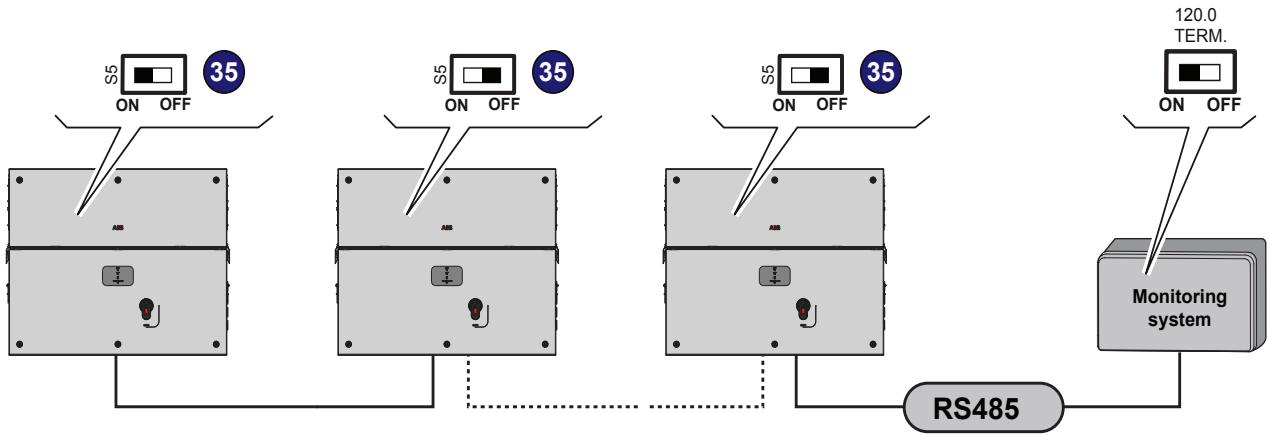

The communication line must also be terminated on the first element of the chain which normally corresponds to the monitoring device.



It is recommended not to exceed a length of 1000m for the communication line.
The maximum number of inverters that can be connected to the same RS485 line is 62.
In case of longer communication line and/or in case of a large number of connected inverters to the same line it could be necessary to add a RS485 amplifier to guarantee the performance of the communication line.

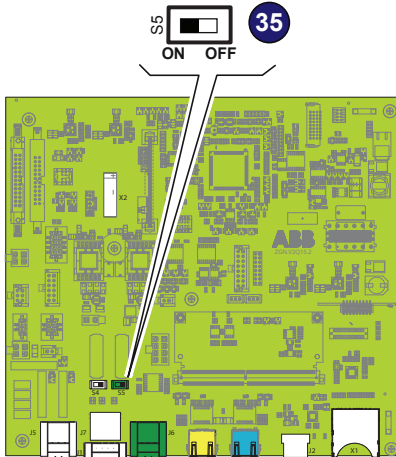

When connecting a single inverter to the monitoring system, activate the communication line resistance terminal by setting the switch 35 (to the ON position).

Set a different RS485 address on each inverter in the chain. **No inverter can have “Auto” as an address.** An address can be freely chosen between 2 and 63.

The setting of the address on the inverter is done through the integrated Web User Interface (refer to chapter “Web User Interface”).

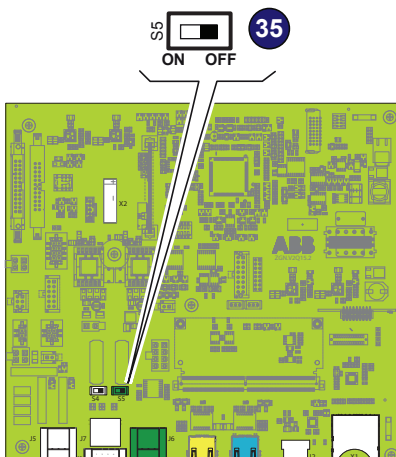

When an RS-485 connection is being used, if one or more inverters are added to the system at a later time, it is necessary to remember to reset to OFF the switch of the termination resistance being used (1) or (2) on the inverter which previously was the last in the system.

Each inverter is shipped with the RS485 address pre-set to two (2) and with the resistance terminal setting Switch 35 in the OFF position.

Serial communication connection (RS485 - Master mode)

The RS485 port 38 can either be used for connecting supported accessories (like weather station): in this case data from accessories will be logged and transferred to the cloud by inverter itself (master mode). This allow to use the inverter as logger also for FIMER accessories.

To know how to connect the accessories to the RS485 terminal block refer to accessory product manual or contact FIMER customer support.

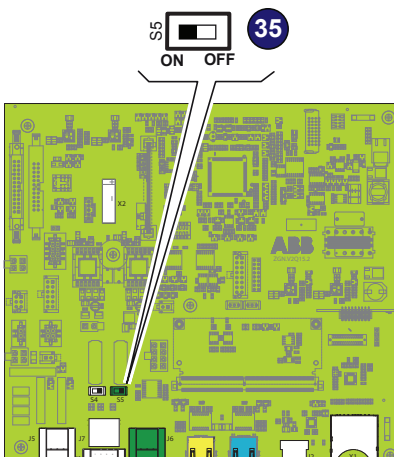
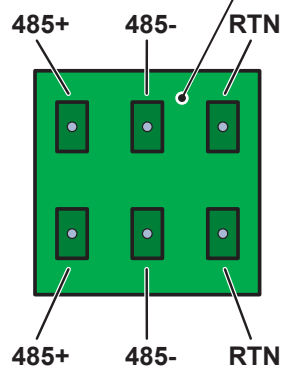
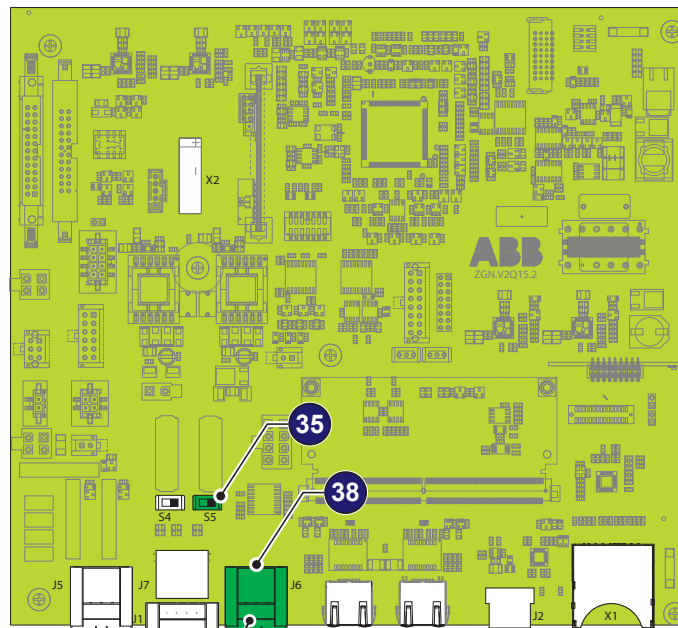

When the RS485 port 38 is configured as Master, the switch of the termination resistance 35 have to be set to "ON" position.

When an accessory is connected to the RS485 port it must be added and configured into the "Monitored device" list on the integrated Web User Interface (refer to chapter "Web User Interface").

Remote control connection

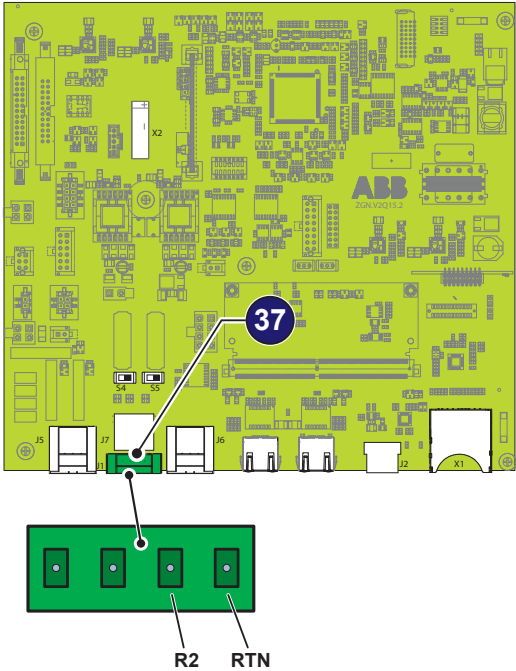

The connection and disconnection of the inverter to and from the grid can be controlled through an external control. The function must be enabled in the relevant menu of the Web User Interface. If the remote control function is disabled, the switching on of the inverter is dictated by the presence of the normal parameters which allow the inverter to connect to the grid.

If the remote control function is operating, besides being dictated by the presence of the normal parameters that allow the inverter to connect to the grid, the switching on of the inverter also depends on the state of the R2 terminal compared to the RTN terminal present on the 37 connector of the communication and control board 28.

When R2 signals is brought to the same potential as the RTN signal (i.e. by making a short circuit between the two terminals of the connector), this causes the inverter to disconnect from the grid.

The connections of these controls are made between the R2 input compared to the common RTN signal. Since this is a digital input, there are no requirements to be observed as regards cable cross-section (it only needs to comply with the sizing requirement for passing cables through the cable glands and the terminal connector).

Demand Response Mode 0 (AS/NZS 4777.2)

Where requested by the AS/NZS 4777.2 standard, it's possible to use the Remote terminal block 37 for the Demand Response Mode 0 (DRM0) functionality.

Refer to dedicated DRM0-INTERFACE product documentation to know how to properly connect the device to the inverter.



For further information regarding the DRM0 function refer to the AS/NZS 4777 standard.

Configurable Relay connection (ALARM and AUX)

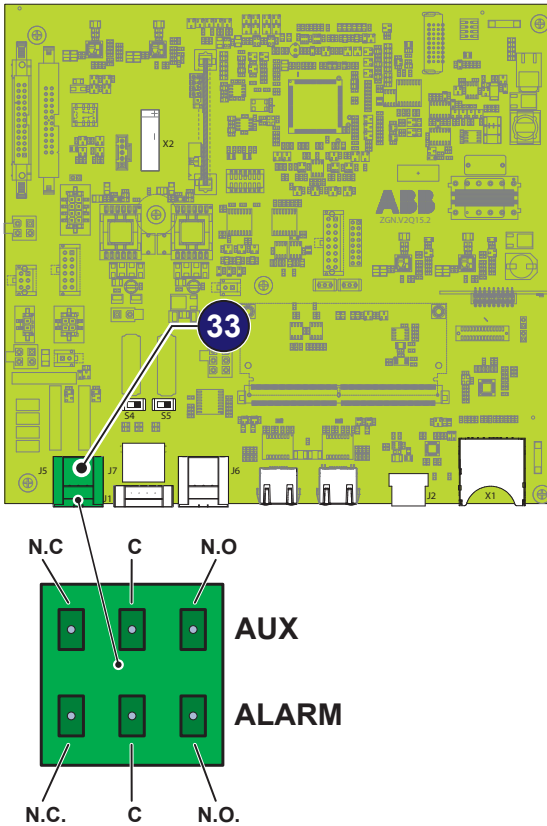

The inverter is equipped with 2 multifunction relays **33** with configurable activation. It can be connected with normally open contact (being connected between the N.O. terminal and the common contact C) and with normally closed contact (being connected between the N.C. terminal and the common contact C). Different types of devices (light, sound, etc.) can be connected to the relay, provided they comply with the following requirements:

Alternating current

Maximum Voltage: 160 V AC

Maximum Current: 6 A

Direct current

Maximum Voltage: 30 V DC

Maximum Current: 3 A

Cable requirements

External diameter: 6 mm

Conductor cross-section: from 28 to 16 AWG



This contact can be used in different operating configurations that can be selected by accessing the relevant section in the web user Interface "SETTINGS > Digital Outputs".

General conditions

One of the first rules for preventing damage to the equipment and to the operator is to have a thorough knowledge of the instruments. We, therefore, advise that you carefully read this manual. If you are not sure about any information in this manual, please ask FIMER Service for more detailed information.



Do not use the equipment if:

- *you do not have suitable qualifications to work on this equipment or similar products;*
- *you are unable to understand how it works;*
- *you are not sure what will happen when the buttons or switches are operated;*
- *you notice any operating anomalies;*
- *there are doubts or contradictions between your experience, the manual and/or other operators.*

FIMER cannot be held responsible for damage to the equipment or the operator if it is the result of lack of knowledge, insufficient qualifications or lack of training.

Description of the LED function

The LEDs  functions on the inverter are described below.

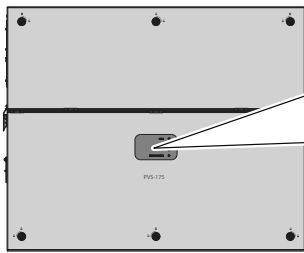

POWER

Indicates that the inverter is functioning correctly. When the unit is commissioned, while the grid is checked, this LED blinks. If a valid grid voltage is detected, the LED remains continuously lit, as long as there is sufficient sunlight to activate the unit. Otherwise, the LED will continue to blink until the sunlight is sufficient for activation.



ALARM

Indicates that the inverter has detected an anomaly. This type of problem is highlighted in the Web User Interface and FIMER Installer for Solar Inverters APP.



GFI

The “GFI” (ground fault) LED indicates that the inverter has detected a ground fault in the DC side photovoltaic generator. When this fault is detected, the inverter immediately disconnects from the grid.



WLAN/LAN

Indicates the status of the Wireless or ETHERNET communication lines.

The LEDs, in various multiple available combinations, can signal multiple conditions other than the original single condition; see the various descriptions explained in the “Power, Alarm, GFI LEDs behaviour” and “WLAN/LAN LED behaviour” chapters on this manual.

User interface

1. FIMER Installer for Solar Inverters

- Mobile APP improving multiple inverter commissioning and system settings with FIMER Installer for Solar Inverters APP.
- Compatible with Android devices.
- Updating of the inverter firmware.

2. Embedded Web User Interface

- Accessible via Wi-Fi by using any WLAN enabled standard device (PC, smartphone, tablet,....)
- Enables single inverter commissioning and parameters settings.
- Updating the inverter firmware.

3. Aurora Vision Plant Management Platform

Additional to any local user interfaces the inverter comes with capability enabling remote monitoring and managing via Aurora Vision Plant Management Platform cloud. Aurora Vision offer includes:

- Plant Portfolio Manager: web portal for solar professional.
- Plant Viewer: single web page for casual user.
- Plant Viewer for Mobile: mobile application for plant monitoring.
- Kiosk view: single HTML5 page for public visualization of plant data.
- API: web based tool for enabling the sharing of the data with a third party data.

Measurement tolerance

The data supplied by the inverter may differ from measurements taken by certified measuring instruments (e.g. output meters, multimeters and grid analysers); since the inverter is not a measuring instrument it has wider tolerances for the measurements it makes.

The tolerances are generally:

- ±5% for real-time measurements with output power below 20%
- ±3% for real-time measurements with output power above 20%
- ±4% for all statistical data.

General conditions

Before checking the operation of the equipment, it is necessary to have a thorough knowledge of the Instruments chapter 6 and the functions that have been enabled in the installation process.

The equipment operates automatically without the aid of an operator; the operating state should be controlled through the equipment's instrumentation.

The interpretation or variation of some data is reserved exclusively for specialized and qualified staff.



The input voltage must not exceed the maximum values shown in the technical data, section 2 in order to avoid damaging the equipment. Consult the technical data for further details.

During operation, check that the environmental and storage conditions are correct (see installation chapter 5).

Make sure that environmental and storage conditions have not changed over time and that the equipment is not exposed to adverse weather conditions.

Commissioning



Do not place objects of any kind on the inverter during operation! Do not touch the heat sink while the inverter is operating! Some parts may be very hot and could cause burns.



Before proceeding with commissioning, make sure you have carried out all the checks and verifications indicated in the section on preliminary checks.



Make sure irradiation is stable and adequate for the inverter commissioning procedure to be completed.



At the first activation of the inverter the firmware version could be synchronized between power module and wiring box. During this phase the LEDs “Power” “Alarm” and “GFI” blink together every 1 second. This process is absolutely normal and must be completed without interruption. A switch-off of the system during this process could cause serious damage to the inverter.

Commissioning could be carried out in two different ways:

- **Via FIMER Installer for Solar Inverters APP**

Recommended mobile APP for commissioning a single inverter as well as a multi-inverter solar plant.

- **Via Web UI (access point wireless network)**

Integrated Web User Interface enabling setting parameters and performing commissioning of a single inverter (multi inverter support is not provided).

Recommended as alternative method for performing single inverter commissioning.

Commissioning via FIMER Installer for Solar Inverters mobile APP

FIMER Installer for Solar Inverters APP is the new advanced FIMER mobile APP which simplifies the commissioning of large scale solar plants thanks to the capability to set parameters of multiple inverters simultaneously.

Even in case of single inverter installation it can be considered the most suitable tool to be used.

FIMER Installer for Solar Inverters APP is available for Android mobile devices with an Android version of 6.0.1 or greater (for iOS mobile devices will be implemented soon) and could be downloaded and installed from Play Store.

The requirements to complete the procedures are listed below:

- FIMER Installer for Solar Inverters APP installed on mobile device.
 - Enabled installer account for FIMER Installer for Solar Inverters APP
- The account could be created in the mobile app directly following the dedicated wizard procedure.
- Manual claiming of the inverters to be commissioned.

The claiming process consist of indicating which inverters are to be commissioned

Claiming process can be performed by taking pictures of the QR codes of single inverter units (printed on the Communication identification label) (recommended); manual insertion of the MAC address and related product keys of all the inverters that shall be commissioned; scanning and selecting of SSIDs associated to the Wi-Fi networks generated by each inverter to commission.

- Close the DC disconnect switches **15** to supply the inverter with input voltage from the photovoltaic generator.



Make sure irradiation is stable and adequate for the inverter commissioning procedure to be completed.

- Perform the installation wizard steps enabling the transferring the settings to all the claimed inverters.



For more details about the procedure for commissioning with the FIMER Installer for Solar Inverters APP refer to dedicated documentation on the FIMER solar website.



For any other specific settings of parameters of single inverters please refer to “Description of the Web User Interface” chapter.

After the commissioning via FIMER Installer for Solar Inverters APP is completed, the inverter changes the behaviour of the “Power” and “Alarm” LEDs ⁰⁸, in relation of the input voltage value:

Input voltage	LED Status	Description
$V_{in} < V_{start}$	Power = Flashing Alarm = OFF	The input voltage is not sufficient to enable connection to the grid.
$V_{in} > V_{start}$	Power = Flashing Alarm = ON	The input voltage is sufficient to enable connection to the grid: the inverter waits for the grid voltage to be present to make the connection to the grid.



The inverter is powered SOLELY by the voltage generated by the photovoltaic generator: the presence of grid voltage alone is NOT SUFFICIENT for the inverter to switch on.

- When the input voltage is sufficient to allow the connection to the grid, close the AC switch downstream of the inverter (and AC disconnect switch ⁰⁹ for the -SX2, -SY2 wiring box version) thus applying the grid voltage to the inverter: the inverter checks the grid voltage, measures the isolation resistance of the photovoltaic field with respect to ground and performs other auto-diagnostic checks. During the preliminary checks on the parallel connection with the grid, the “Power” LED keeps flashing, the “Alarm” and “GFI” LEDs are OFF.

- If the outcome of the preliminary checks on the grid parallel is positive, the inverter connects to the grid and starts to export power to the grid. The “Power” LED remains fixed on while the “Alarm” and “GFI” LEDs are OFF.



To address any problems that may occur during the initial stages of operation of the system and to ensure the inverter remains fully functional, you are advised to check for any firmware updates in the dedicated section of web user interface or in the download area of the website www.fimer.com. or at <https://registration.solar.fimer.com> (instructions for registering on the website and updating the firmware are given in this manual).

Commissioning Via Web UI - Wireless connection

CONNECTION TO THE INVERTER - WIRELESS

Commissioning could be carried out via wireless connection to the inverter's Web User Interface. Initial setup of the system must therefore be carried out via a tablet, notebook or smartphone with a wireless connection.

- Close the DC disconnect switches **15** to supply the inverter with input voltage from the photovoltaic generator.



Make sure irradiation is stable and adequate for the inverter commissioning procedure to be completed.

- Once powered, the inverter will automatically create a wireless network (approx. 60 seconds after its switch-on).
- Enable the wireless connection on the device which is being used for the board setup (tablet, smartphone or PC) and connect it to the Access Point created by the inverter system: the name of the wireless network created by the system that the connection should be established with, will be: ABB-XX-XX-XX-XX-XX-XX where "X" is a hex digit of the wireless MAC address (MAC address can be found on the "Communication Identification Label" placed on the side of the inverter).



The screens shown below pertain to a tablet with the Android operating system. Screens on other devices or operating systems may differ.



- When required enter the **PRODUCT KEY** (printed on the "Communication Identification label" and applied during the commissioning phase to the plant documentation) as access point password.

Note that it's required to digit also the dash "-" characters of the Product Key in the password field.



In case of need, product key can be recovered by Aurora Vision Cloud of by calling FIMER technical support.

COMMISSIONING PROCEDURE - WIRELESS CONNECTED

- Open an internet browser (recommended browser: Chrome versions from v.55, Firefox versions from v.50) and enter the pre-set IP address **192.168.117.1** to access the Web User Interface. Web User interface has easy commissioning wizard to commission the inverter.



The language of the wizard could be changed by clicking on the upper status bar

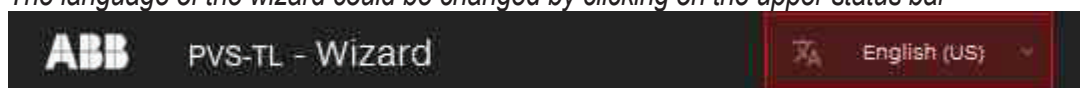

The required informations during the procedure are:

STEP 1 - Administrator/User login credentials

Administrator account

Admin ⓘ

Username

Required

Password ⓘ

Password

Required

Confirm Password ⓘ

Re-enter Password

Required

User account

User ⓘ

Username

Required

No user password

- Set the **Administrator** account user and password (minimum 8 character for password):
Administrator account can open and view the contents of photovoltaic site. Additionally, they can make changes to inverter settings.
User and password are CASE SENSITIVE.
- Set the **User** account user and (optional) password (minimum 8 character for password):
User account can only read data. It cannot make any changes.
User and password are CASE SENSITIVE.

STEP 2 (Optional) - Wireless network connection.

As described on chapter 2 the recommended way to get all the installed inverters to communicate to the internet and Aurora Vision Cloud is creating a wired Ethernet daisy chain bus. Anyway, in case of a few inverters installation in suitable environment, it is also possible to connect each inverter of the plant to a Wi-Fi router without using any cable.

The AP is still available and the user can connect to the inverter.

In this scenario the Router gives IPs according to its own rules.

Inverter is reachable by IP.

Domain name can be used only if the Router permits multicast

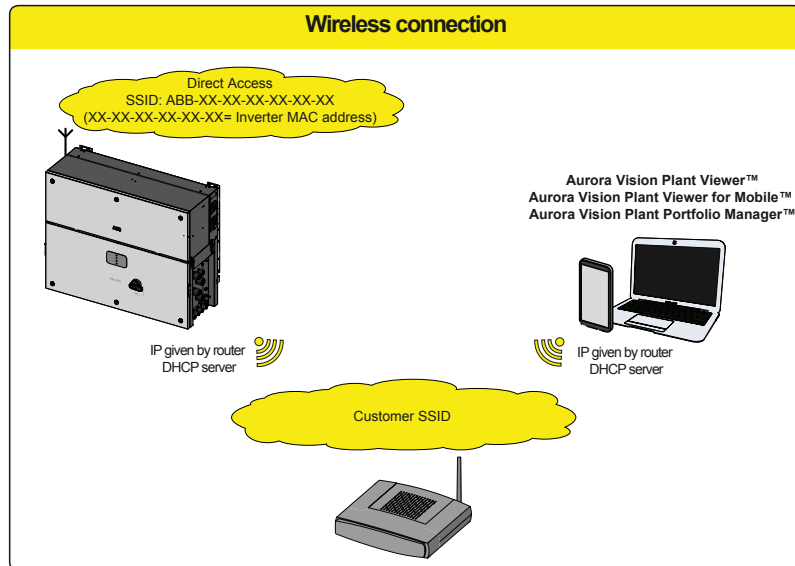

During the installation wizard of the single inverter, the installer will be asked to connect the inverter to a Wi-Fi router. By selecting connection to Wi-Fi router the inverter will turn on a second Wi-Fi radio channel in order to enable connection to the Wi-Fi router. By selecting “Skip this step” button the other radio channel will be kept off.

Two Wi-Fi radio channels enables simultaneous wireless connection; one static IP address connection between inverter and installer devices and one between inverter and switch/router.

Whatever option is used to connect the inverter to the router (Ethernet cable or Wi-Fi) it will be always possible to access to the embedded web server also by connecting its own device to the same switch/router, and reaching the inverter (via second radio channel in case of Wi-Fi connection with the router) by using the assigned IP address or inverter’s host name.



The IP address assigned to the inverter may vary or may be unknown. Please contact the IT administrator for getting the assigned IP address.

Differently from the assigned IP address, the «Host Name» of the inverter is does not change over time.



In order to use the «Host Name» as an alternative to the assigned IP address, for accessing to the inverters web server from the router the Domain Name System (DNS) service shall be available and activated.

The Host Name associated to each FIMER inverter is structured as indicated below:

FIMER-logger ID.LOCAL where:

logger ID stands for the MAC address indicated on the “Communication identification lable” applied on the inverter.

Wireless Network

Skip this step

IP Settings

DHCP

Available Network (SSID)

-- Please select --

Required

Password

Show password

CONNECT

The parameters related to the customer wireless network (set on the router) that must be known and set during this step are:

- IP Settings: DHCP or Static.

If you select the DHCP function (default setup) the router will automatically assign a dynamic IP address to the inverter whenever it tries to connect to the user network.

With Static, the user can assign a fixed IP address to the system. The data which has to be entered in order for IP static address assigning to take place will appear. Complete the additional fields at the bottom of the screen (all the fields are mandatory with the exception of the secondary DNS server).

- Available networks (SSID):

Identify and select your own (customer) wireless network from all those shown in the SSID field (you can carry out a new search of the networks that can be detected with the Update button ).

Once the network has been selected, confirm.

- Password: Wireless network password.

Enter the password for the destination network (if necessary) and start the connection attempt (it will take a few seconds).

Click on “Connect” button to connect the inverter to the home wireless network.

Wireless network connection:

Home_Network

The inverter is going to be connected to the wireless network **Home_Network**

On-going attempt to connect to the wireless network **Home_Network**

Back Next

A message will ask for confirmation. Click “Next” to connect the inverter to the customer wireless network.

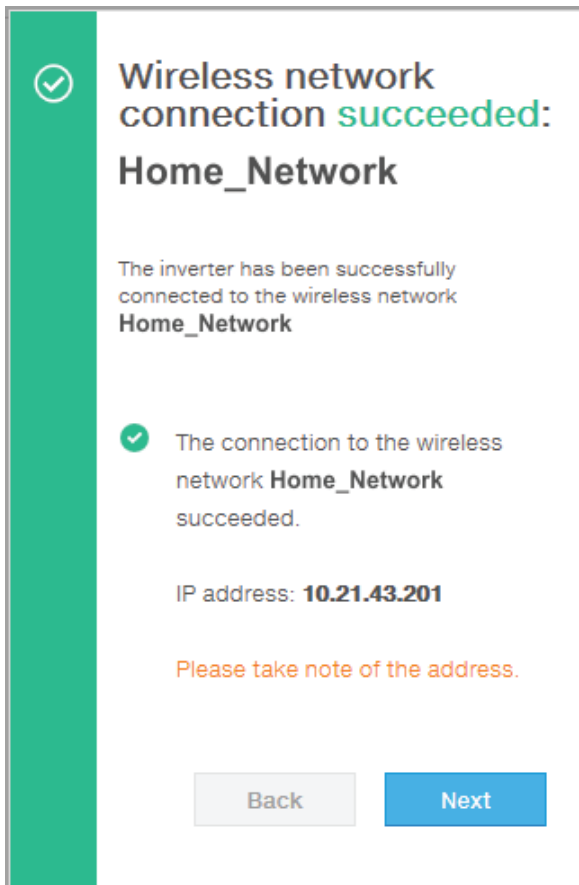

Once the inverter is connected to the customer wireless network, a new message will confirm that the connection is acquired.

The message provides the IP Address assigned by the home wireless network router to the inverter that can be used each time you want to access the Web User Interface, with the inverter connected to the home wireless network. **Take note of it.**

Click on “Next” button to proceed to the next stage of the configuration wizard.



The IP address assigned may vary for reasons connected to the wireless home router setup (for example, a very brief DHCP lease time). If verification of the address is required, it is usually possible to obtain the client list (and the corresponding IP addresses) from the wireless router administration panel.

If the inverter loses the connection with the home wireless network (and therefore, loses the internet connection), it will once again enable its own access point.



The most common causes of losing connectivity might be: different wireless network password, faulty or unreachable router, replacement of router (different SSID) without the necessary setting updates.

STEP 3 - Date, Time and Time zone

Date and Time

✔ Network Time Protocol server has been detected and it will be used to keep the system clock synchronized.

Date ●

Feb 22, 2017

SET by the NTP server

Time ●

3:28 PM

SET by the NTP server

Time Zone

Europe/Berlin GMT+01:00

BACK NEXT

Set the Date, Time and Time zone (The inverter will propose these fields when available).

Date and Time

⊙ Network Time Protocol server has not been detected. Clock isn't synchronized. The displayed date and time come from the inverter or have been manually set up.

Please set the correct system date and time if needed.

Date and time will be automatically updated as soon as an NTP server is available.

Date

2/8/17

Time

11 : 56 AM

Time Zone

Europe/Berlin GMT+01:00

BACK NEXT

When it's not possible for the inverter to detect the time protocol, these fields have to be manually entered.

Click on "Next" button to proceed to the next stage of the configuration wizard.

STEP 4 - Inverter country standard and Input configuration

- **Country standard: selection of grid standard:**

Set the grid standard of the country in which the inverter is installed.



After the grid standard is set you have 24 hours to make any changes to the grid standard value; 24 hours later the Country Standard sub-menu will be locked, and the remaining time shall be reset in order to have the 24 hours of unlocked operation available again to select a new grid standard (follow the procedure “Resetting the remaining time for grid standard variation” described in the relevant section).

Country standard

Grid Standard

-- Please select --

Required

Input mode

PV Input Channels Configuration

Independent

BACK

END

- **Input mode:**

Only Independent configuration are available.

Confirm the settings by clicking “END” and the inverter will reboot.

A notification will confirm that the wizard is completed.

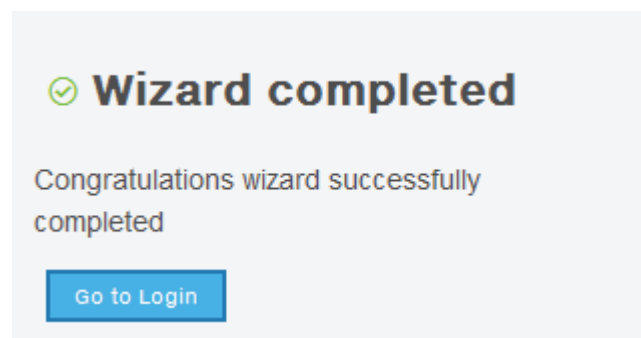

- After the wizard is completed the inverter changes the behaviour of the “Power” and “Alarm” LEDs ⁰⁸ in relation of the input voltage value:

Input voltage	LED Status	Description
$V_{in} < V_{start}$	Power = Flashing Alarm = OFF	The input voltage is not sufficient to enable connection to the grid.
$V_{in} > V_{start}$	Power = Flashing Alarm = ON	The input voltage is sufficient to enable connection to the grid: the inverter waits for the grid voltage to be present to make the connection to the grid.



The inverter is powered SOLELY by the voltage generated by the photovoltaic generator: the presence of grid voltage alone is NOT SUFFICIENT for the inverter to switch on.

- When the input voltage is sufficient to allow the connection to the grid, close the AC switch downstream of the inverter (and AC disconnect switch ⁰⁹ for the -SX2, -SY2 wiring box version) thus applying the grid voltage to the inverter: the inverter checks the grid voltage, measures the isolation resistance of the photovoltaic field with respect to ground and performs other auto-diagnostic checks. During the preliminary checks on the parallel connection with the grid, the “Power” LED keeps flashing, the “Alarm” and “GFI” LEDs are OFF.
- If the outcome of the preliminary checks on the grid parallel is positive, the inverter connects to the grid and starts to export power to the grid. The “Power” LED remains fixed on while the “Alarm” and “GFI” LEDs are OFF.































To address any problems that may occur during the initial stages of operation of the system and to ensure the inverter remains fully functional, you are advised to check for any firmware updates in the dedicated section of web user interface or in the download area of the website www.fimer.com or at <https://registration.solar.fimer.com> (instructions for registering on the website and updating the firmware are given in this manual).



















Power, Alarm, GFI LEDs behaviour

The following table shows all the possible activation combinations of “Power” “Alarm” and “GFI” LEDs on the LED panel  according to the operating status of the inverter.

All possible LED activation combinations are shown in the following table. In particular, each LED could behave in one of the following ways:





-  = LED on
-  = LED flashing slow (2 seconds on / 2 seconds off)
-  = LED flashing fast (0.2 seconds on / 0.2 seconds off)
-  = LED off
-  = Any one of the conditions described above

LED status	Operating state
green:  yellow:  red: 	Firmware programming The inverter firmware is being programmed.
green:  yellow:  red: 	Night mode (inverter automatically switches off) The inverter is in night time switch-off mode (input voltage less than 70% of the set start-up voltage and AC grid is missing).
green:  yellow:  red: 	Inverter initialization / Waiting Sun This is a transitional state due to verification of the operating conditions. During this stage the inverter checks that the conditions for connecting to the grid are met.
green:  yellow:  red: 	The inverter is connected and is feeding power into the grid Normal operation. During this stage, the inverter automatically tracks and analyses the photovoltaic generator's maximum power point (MPP).
green:  yellow:  red: 	Missing grid Indicates lack of grid voltage. This condition does not allow the inverter to connect to the grid.
green:  yellow:  red: 	Warning indication: (W message codes) or Error: (E message codes) - Indicates that the inverter control system has detected a warning (W) or error (E). It is possible to identify the type of problem generated in the dedicated section of integrated Web User Interface (“Inverter Log” section).
green:  yellow:  red: 	Temperature protection trip Indicates that the trip relating to internal temperatures (insufficient or excessive temperature) may have been activated.
green:  yellow:  red: 	Anomaly in the insulation system of the photovoltaic generator Indicates that a leakage to earth from the PV generator has been detected, causing the inverter to disconnect from the grid.

LED status	Operating state
	<p>Ventilation anomaly Indicates an anomaly in the operation of the internal ventilation system that could limit output power at high ambient temperatures.</p>
green:  yellow:  red: 	<p>Overvoltage surge arresters triggered (where fitted) Indicates that any class II overvoltage surge arresters installed on the AC or DC side have been triggered</p>
	<p>Internal statistics memory anomaly Indicates an operating anomaly in the internal memory on which the inverter statistics are stored</p>
	<p>Buffer battery discharged The buffer battery is low and the inverter does not maintain the time setting</p>
	<p>Pre-commissioning phase (first start-up of inverter) The commissioning of the inverter must be completed through the Installation wizard steps (Web User Interface) or using the FIMER Installer for Solar Inverters mobile APP</p>
green:  yellow:  red: 	<p>Initial configuration failure The inverter is in locked state due to a failure in the initial configuration of the equipment, such as the standard network setting for the country of installation</p>
	<p>Self-test not carried out (for Italian grid standards only) Self-test operation failure</p>
	<p>Incompatibility of the device firmware versions The firmware versions of the various devices comprising the equipment are incompatible and are being updated (this is an automatic operation)</p>
	<p>Temperature sensor anomaly detected</p>
green:  yellow:  red:  * lighting of the LEDs in sequence	<p>Updating the firmware from an SD card The equipment firmware is being updated from an SD card</p>
green:  yellow:  red: 	<p>Updating the firmware from an SD card has failed The equipment firmware update from an SD card has failed</p>
green:  yellow:  red:  *blink 3 times	<p>Updating the firmware from an SD card completed The equipment firmware has been successfully updated from an SD card</p>
green:  yellow:  red: 	<p>Remote OFF activated The Remote Off command has been activated. The unit will not connect to the network until the remote ON command has been activated</p>

WLAN/LAN LED behaviour

The following table shows all the possible status of “WLAN/LAN” LED on the LED panel  according to the operating status of the wireless or ethernet communication lines.

LED status	Operating state
Blue: 	Wireless not configured or/and ethernet cable not connected.
Blue: 	Scanning for available wireless networks.
Blue: 	Trying to connect to a wireless network.
Blue: 	Wireless or ethernet network is connected to the inverter and IP address is obtained.

Description of the Web User Interface

The inverter is equipped with an advanced integrated Web User Interface and user interface that allow a full access to all configuration and commissioning parameters from any electronic device (laptop, tablet and smartphone).

Access to the Web User Interface

To access to the Web User Interface is required to connect a device equipped with wireless connection (such as tablet, laptop or smartphone).

Depending on the connection method chosen during the inverter commissioning phase ("Station Mode" or "AP Mode") it's required to follow one of the two procedures described below:

Connection to the inverter in "Station Mode"

- Enable the wireless connection on the device (tablet, smartphone or laptop) and connect it to the same wireless network to which the inverter is connected.
- Open an internet browser (recommened browser: Chrome versions from v.55, Firefox versions from v.50) and enter the links (corresponding to the IP Address assigned by the router to the inverter, or the "Host Name") provided during the commissioning phase to access the login page.

 In order to use the "Host Name" as an alternative to the dynamic IP address, the Wireless router to which the board is connected (when operating in "Station Mode") must provide the Domain Name System (DNS) service (contact the network administrator for further information regarding the presence or absence of the DNS service in the Wireless router or how to enable it). In this way, even if the IP address assigned to the inverter should change over time, (dynamic IP), it will always be possible to use the same "Host Name" which will remain unchanged over time.

 The IP address assigned may vary for reasons connected to the wireless home router setup (for example, a very brief DHCP lease time). If verification of the address is required, it is usually possible to obtain the client list (and the corresponding IP addresses) from the wireless router administration panel.

If the "Host Name" was lost, it could be obtained writing this url:

<http://ABB-XX-XX-XX-XX-XX-XX.local>

 replacing the "X" with the hex digits of the MAC address of the inverter (it can be found on the "Communication Identification label" placed on the side of the inverter or applied during the commissioning phase to the plant documentation).

Connection to the inverter in “AP Mode”

- Enable the wireless connection on the device which is being used for the board setup (tablet, smartphone or PC) and connect it to the Access Point created by the inverter system: the name of the wireless network created by the system that the connection should be established with, will be:

ABB-XX-XX-XX-XX-XX-XX

where “X” is a hex digit of the MAC address (MAC address can be found on the “Communication Identification label” placed on the side of the inverter or applied during the commissioning phase to the plant documentation).

- When required digit the **PRODUCT KEY** (printed on the “Communication Identification label” and applied during the commissioning phase to the plant documentation) as access point password.

Note that it’s required to digit also the dash “-” characters of the Product Key in the password field.



In case of need, product key can be recovered by Aurora Vision Cloud or by calling FIMER technical support.

- Open an internet browser (recommened browser: Chrome versions from v.55, Firefox versions from v.50) and enter the pre-set IP address **192.168.117.1** to access the login page.

Login page

After you have connected the device to the inverter and you access to the login page, login with the username and password created during the commissioning phase.



User and password are CASE SENSITIVE.



If the Password is lost click on “Forgot your password?” to obtain the access to the Web User Interface (and it will be possible to change the password) by entering the PRODUCT KEY (printed on the “Communication Identification label” and applied during the commissioning phase to the plant documentation).



The language of the Web User Interface could be changed in any moment by clicking on the right status bar:

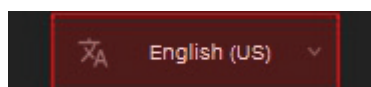

Web User Interface menu structure



The following screenshots are related from a laptop visualization, may differ from smartphone or tablet visualization.

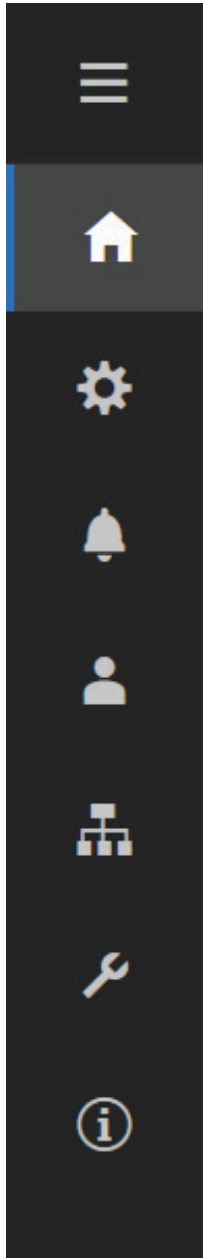

The Web User Interface is divided in six main sections, available on the left sidebar:

MAIN: Main section of Web User Interface dedicated to viewing the summary informations related the status and the production informations of the inverter and photovoltaic plant.

SETUP: Section dedicated to AC and DC line parameters configurations.

EVENTS: Section dedicated to viewing Alarms and Warnings event log.

USER: Section dedicated to User management.

NETWORK: Section dedicated to inverter communication settings and configurations.

TOOLS: Section dedicated to main service tools configurations.

INFORMATION: Section dedicated for general informations about the embedded Web User Interface.



MAIN section

In the **MAIN** section it's possible to access the following sub-menus:

- **Dashboard**
- **Status Summary**
- **String combiner**

Dashboard

In the **Dashboard** sub-menu you can view the main informations related the status and the production informations of the inverter and photovoltaic plant and alarm/warning active events.

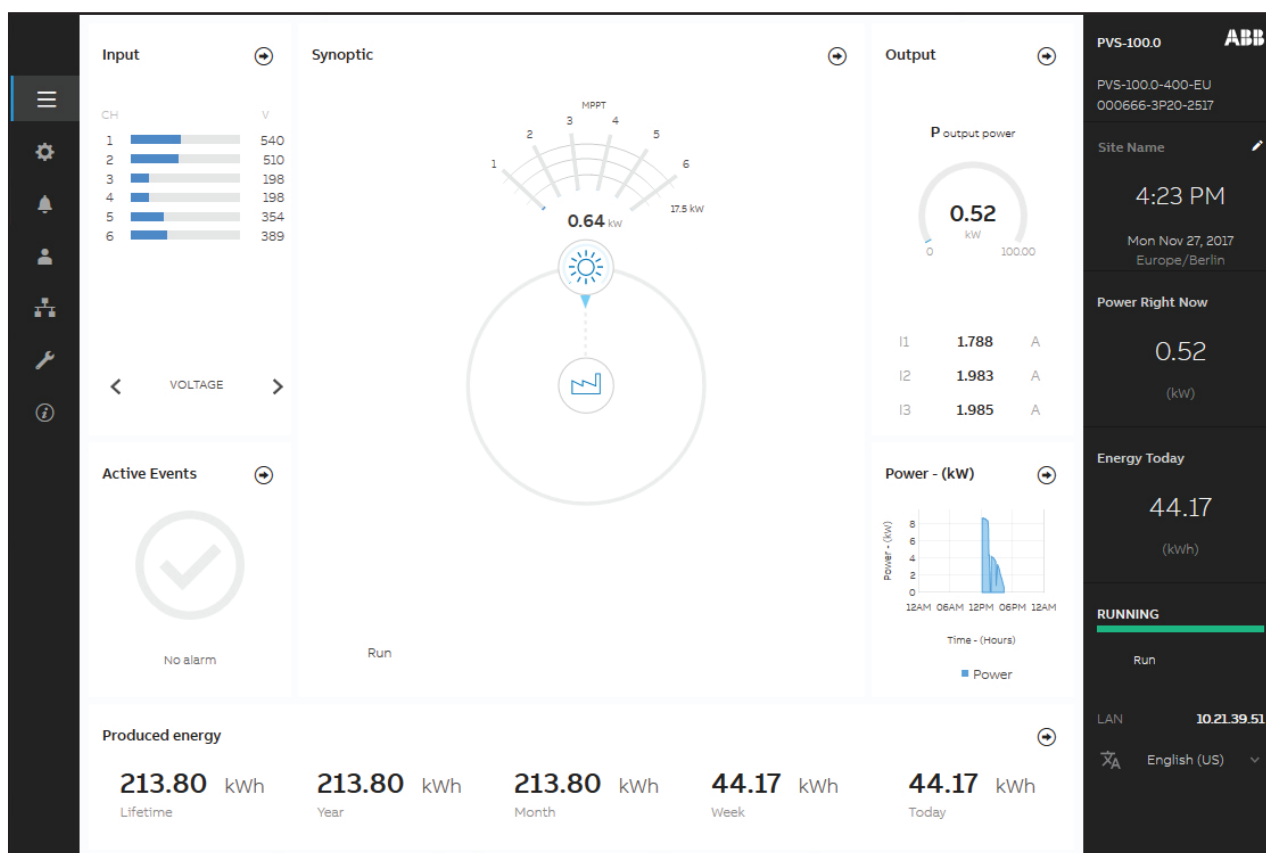

Status Summary

In the **Status Summary** sub-menu you can view the detailed informations related the status and the production informations of the system.



String combiner

In the **String combiner** sub-menu you can view the detailed informations related the status and parameters for each input channel.

A summary tab is available to view the status and parameters for each input channel and to set the “TRIGGER TIME” and the “GROUP” of the channel:

String Combiner Summary Edit

Trigger Time 10 min

CH	STATUS	POWER (KW)	CURRENT (A)	GROUP
1	✓ normal	0.00	0.0	PV Group 5
2	⊘ unused	0.00	0.0	PV Group 5
3	✓ normal	0.00	0.0	PV Group 5
4	! interrupted	0.00	0.0	PV Group 6
5	✓ normal	0.00	0.0	PV Group 5
6	! interrupted	0.00	0.0	PV Group 6

- **Trigger time:** It allows you to set the minimum elapsed time of abnormal working condition needed to trigger an alarm event (current unbalance, interrupted).
- **Group:** It allows you to set the individual group for each channel. For a correct string monitoring it's necessary to assign at the channels, that have the same configuration of the PV strings (number of strings, type of panel and orientation), the same group.

For each channel a detailed status tab is available.

Channel 6 - Strings Edit

ID	STATUS	CURRENT (A)	STRINGS NR.	TOLL. %
6A	! unbalan...	0.50	1	52
6B	! interrup...	-0.08	1	30
6C	⊘ unused	0.95	OFF	40
6D	✓ normal	1.06	1	30

In these tabs it could be possible to set the number of the connected strings for each input and the relative tolerance between the string current and the maximum current of the assigned group of the channel (only available for -SX2 / -SY2).

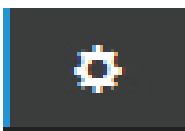

SETTING section

In the **SETTING** section it's possible to access the following sub-menus:

- **Inverter Parameters**
- **Digital Output**

in the Inverter Parameters menu there are the following sub-menus:

- **AC output Rating** (*Only visible with Admin Plus privileges*)
- **AC Settings** (*Only visible with Admin Plus privileges*)
- **Active Power Control** (*Only visible with Admin Plus privileges*)
- **DC Settings**
- **Digital Inputs**
- **Frequency Control: P(f)** (*Only visible with Admin Plus privileges*)
- **Ramp Control** (*Only visible with Admin Plus privileges*)
- **Reactive Power Control** (*Only visible with Admin Plus privileges*)

Inverter Parameters > AC output Rating (Only visible and editable with Admin Plus privileges)

In the **AC output Rating** sub-menu you can config the output power limitation by changing the Maximum AC output power and the maximum apparent output power parameters.



Do not change these parameters if not requested by the grid operator.

Inverter Parameters > AC Settings (Only visible and editable with Admin Plus privileges)

In the **AC Settings** sub-menu you can setup the parameter related to the Output AC side:



Changing the above-mentioned parameters may prevent disconnection from the grid if the new values exceed those given in the standards of the country of installation. If these parameters are changed to values outside the standard range, an interface protection must be installed external to the inverter in accordance with the requirements of the country of installation.

1. Grid Protections - VRT/FRT

By editing these settings it's possible to enable/disable and change the grid protection intervention thresholds parameters. In addition it is possible to change voltage ride through (HVRT, LVRT) and frequency ride through (HFRT, LFRT) settings.

2. Grid Connection

By editing these settings it's possible to change the grid connection thresholds parameters to which the inverter have to connect to the grid.

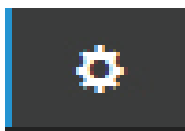

Inverter Parameters > Active Power Control (Only visible and editable with Admin Plus privileges)

In the **Active Power Control** sub-menu you can config settings related to the active power derating parameters using the following parameters groups:

1. **Active Power Curtailment**
2. **CEI Average VGrid Derating**
3. **Volt/Watt settings: P(V)**



Do not change these parameters if not requested by the grid operator.

Inverter Parameters > DC Settings

In the **DC Settings** sub-menu you can setup the parameter related to the Input DC side:

1. VStart 1 New Value

This parameter is used to sets the Vstart activation voltage for the input channel 1. This voltage imposes a minimum input voltage on the inverter above which connection to the grid will be attempted.

2. VStart 2 New Value

This parameter is used to sets the Vstart activation voltage for the input channel 2. This voltage imposes a minimum input voltage on the inverter above which connection to the grid will be attempted.

3. VStart 3 New Value

This parameter is used to sets the Vstart activation voltage for the input channel 3. This voltage imposes a minimum input voltage on the inverter above which connection to the grid will be attempted.

4. VStart 4 New Value

This parameter is used to sets the Vstart activation voltage for the input channel 4. This voltage imposes a minimum input voltage on the inverter above which connection to the grid will be attempted.

5. VStart 5 New Value

This parameter is used to sets the Vstart activation voltage for the input channel 5. This voltage imposes a minimum input voltage on the inverter above which connection to the grid will be attempted.

6. VStart 6 New Value

This parameter is used to sets the Vstart activation voltage for the input channel 6. This voltage imposes a minimum input voltage on the inverter above which connection to the grid will be attempted.



Change the activation voltage only if really necessary and to set it to the correct value: the photovoltaic generator sizing tool available on the FIMER website will indicate whether Vstart needs to be changed and what value have to be set.

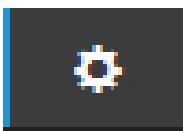

7. Input Mode

This settings allows you to sets the input configuration mode.
Only Independent configuration are available.

8. UV Protection Time

This section of the menu allows you to sets the time for which the inverter stays connected to the grid after the input voltage has dropped below the Under Voltage limit (set at 70% of Vstart).
(60 seconds is the default setting).

9. Multiple Max Scan Enable

This settings allows you to Enables/disables the scan for identifying the maximum power point of the system.

10. Multiple Max Scan Period

This settings allows you to sets the time between scans. Remember that the shorter the scan interval the greater the loss of production, due to the fact that energy is transferred to the grid during the scan but not at the maximum power point. Each scan takes roughly 2 seconds.

Inverter Parameters > Digital Inputs

In the **Digital Inputs** sub-menu you can disable or enable the Remote ON/OFF functionality related to the “Remote” terminal block .

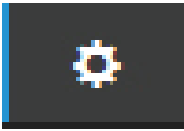

Inverter Parameters > Frequency Control: P(f) (Only visible and editable with Admin Plus privileges)

In the **Frequency Control: P(f)** sub-menu you can config settings related to the active power derating as function of grid frequency.



Do not change these parameters if not requested by the grid operator.

Inverter Parameters > Ramp Control (Only visible and editable with Admin Plus privileges)

In the **Ramp Control** sub-menu you can config the parameter related to the active power ramp up at the start-up and after a grid fault event.



Do not change these parameters if not requested by the grid operator.

Inverter Parameters > Reactive Power Control (Only visible and editable with Admin Plus privileges)

In the **Reactive Power Control** sub-menu you can configure settings related the reactive power parameters using the following parameters groups:

1. **Watt/Cosphi Settings: Cosphi(P)**
2. **Q Set**
3. **Cosphi Set**
4. **Volt/VAr Settings: Q(V)**



Do not change these parameters if not requested by the grid operator.

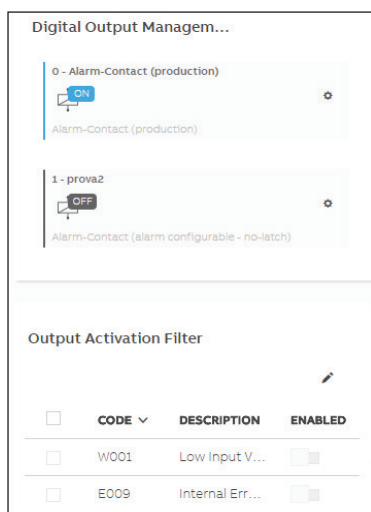
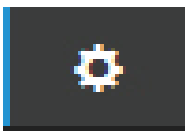

DIGITAL OUTPUTS:

In the **Digital Outputs** menu it's possible to set the activation status of the two configurable relays related to "ALARM" and "AUX" terminal block 33 (refer to "Configurable Relay connection (ALARM and AUX)" chapter to know how to connect to these terminal block) and to configure customised alarm conditions.

This contact can be used, for example, to activate a siren or a visual alarm, control the disconnect device of an external transformer, or control an external device.

Relay switching can be set in different modes using the setting icon : With "Output active filter" you can select the list of events for which the relays switch.

The available operating mode are:

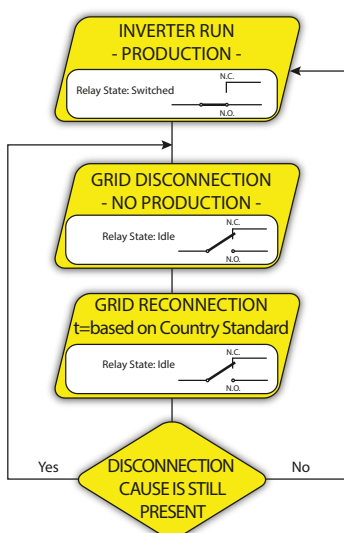

1. Production

The relay is activated (status: switched) whenever the inverter connects to the grid; as soon as the inverter is disconnected from the grid (for whatever reason that caused disconnection), the relay is in its resting position.

2. Alarm ALL - no-latch

The relay is activated (status: switched) whenever an error (code Exxx) or warnings related to grid parameters out of range (Warning – codes W003, W004, W005, W006, W007) are present on the inverter. The alarm contact returns to its resting position when the alarm signal ends, i.e. before the inverter checks the grid parameters after the alarm state. This is because grid control state is not an alarm state but a state of normal operation.

Alarms for which the relay is activated

E001	E002	E003	E004	E005	E006
E007	E009	E010	E011	E012	E013
E014	E015	E016	E017	E018	E019
E020	E021	E022	E023	E024	E025
E026	E027	E028	E029	E030	E031
E032	E033	E034	E035	E036	E037
E046	E050	E053	E054	E055	E056
E057	E058	E077	E078	E081	E084
E089	W003	W004	W005	W006	W007

In the presence of W003, W004, W005, W006, W007 signalling, the alarm contact switches to then reset itself at the end of the alarm signal. This means that during the absence of grid voltage (display message "Missing Grid") the alarm contact remains in its resting position.

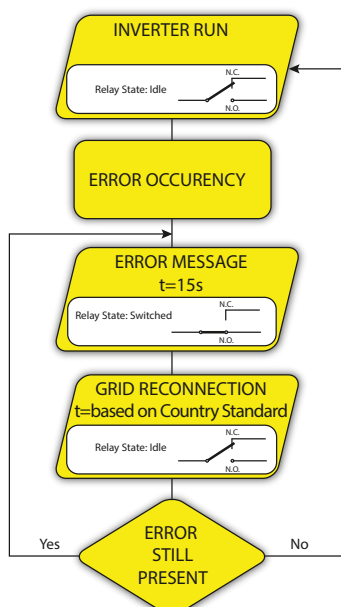

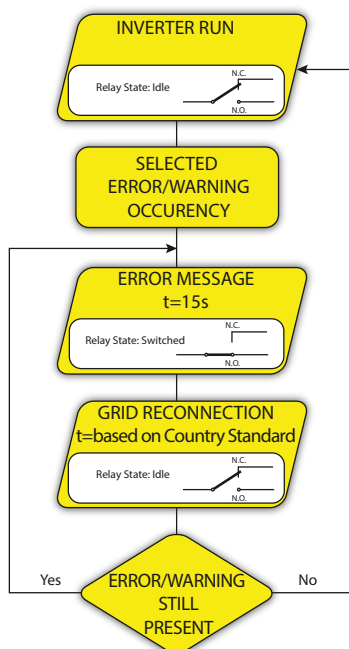
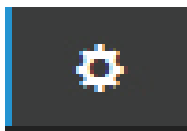

3. Alarm Configurable - no-latch

The relay is activated (status: switched) whenever an error (code Exxx) or a warning (code Wxxx) is among those selected from the list in the dedicated submenu **Alarm Config**. The contact returns to its resting position when the alarm signal ends, i.e. before the inverter checks the grid after the alarm state. This is because grid control state is not an alarm state but a state of normal operation.

Selectable alarms for which the relay is activated

E001	E002	E003	E004	E005	E006
E007	E009	E010	E011	E012	E013
E014	E015	E016	E017	E018	E019
E020	E021	E022	E023	E024	E025
E026	E027	E028	E029	E030	E031
E032	E033	E034	E035	E036	E037
E046	E050	E053	E054	E055	E056
E057	E058	E077	E078	E081	E084
E089	W001	W002	W003	W004	W005
W006	W007	W009	W011	W015	W046
W047	W048	W051	W058	W059	

For the configurable relay operating mode “Alarm Conf.”, the following considerations are valid:

If the alarm condition is persistent, the alarm contact cyclically switches from its resting state to its activated state.

In the presence of W002 signalling (Input UV – input voltage below the limit of operation), the alarm contact switches to then reset itself at the end of the alarm signal. This means that during the reduced input voltage (display message “Waiting Sun”) the alarm contact remains in its resting position.

In the presence of W003, W004, W005, W006, W007 signalling, the alarm contact switches to then reset itself at the end of the alarm signal.

This means that during the absence of grid voltage (display message “Missing Grid”) the alarm contact remains in its resting position.

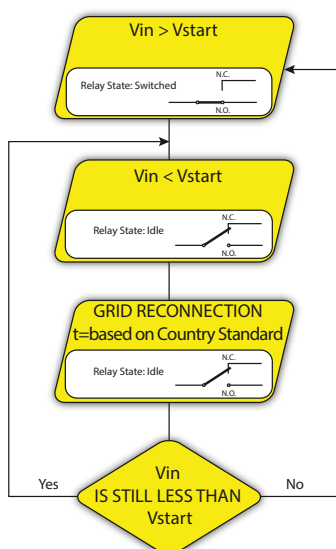

4. Crepuscular

The relay is activated (status: switched) as soon as the inverter input voltage exceeds the activation voltage set.

The relay is in its rest position when the input voltage drops below 70% of the activation voltage set.

This mode is useful for disconnecting any output transformers that could have unnecessary consumption during the night.

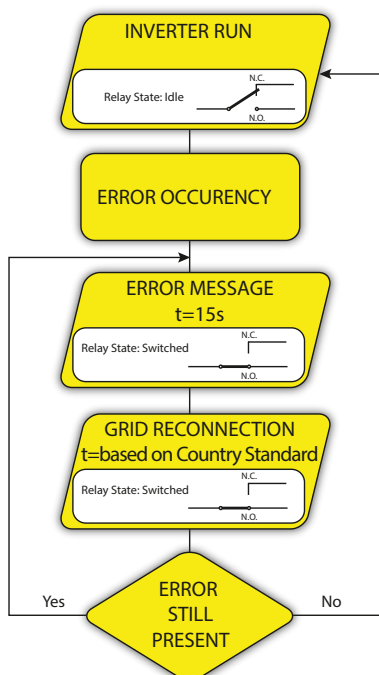
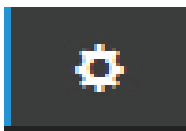

5. Alarm ALL - latch

The relay is activated (status: switched) whenever an error (code Exxx) or a warning (code Wxxx) is present (see the table below). The contact returns to its resting position when the inverter returns to its normal operating state and reconnects to the grid.

Alarms for which the relay is activated

E001	E002	E003	E004	E005	E006
E007	E009	E010	E011	E012	E013
E014	E015	E016	E017	E018	E019
E020	E021	E022	E023	E024	E025
E026	E027	E028	E029	E030	E031
E032	E033	E034	E035	E036	E037
E046	E050	E053	E054	E055	E056
E057	E058	E077	E078	E081	E084
E089	W003	W004	W005	W006	W007

If the alarm condition is persistent, the relay will remain activated (status:switched)

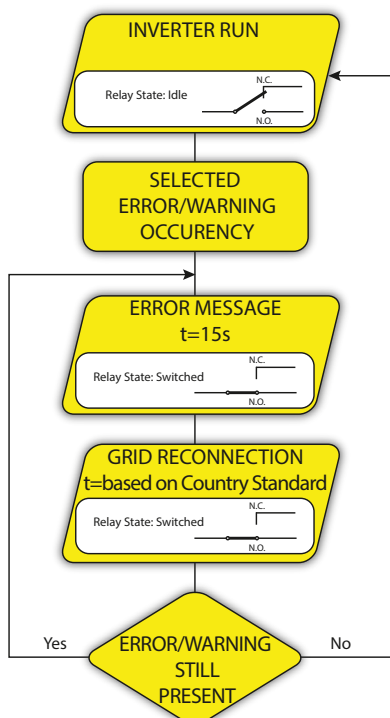

6. Alarm configurable - latch

The relay is activated (status: switched) whenever an error (code Exxx) or a warning (code Wxxx) is among those selected from the list in the dedicated submenu **Alarm Config** (see the table below). The contact returns to its resting position when the inverter returns to its normal operating state and reconnects to the grid.

Selectable alarms for which the relay is activated

E001	E002	E003	E004	E005	E006
E007	E009	E010	E011	E012	E013
E014	E015	E016	E017	E018	E019
E020	E021	E022	E023	E024	E025
E026	E027	E028	E029	E030	E031
E032	E033	E034	E035	E036	E037
E046	E050	E053	E054	E055	E056
E057	E058	E077	E078	E081	E084
E089	W001	W002	W003	W004	W005
W006	W007	W009	W011	W015	W046
W047	W048	W051	W058	W059	

If the alarm condition is persistent, the relay will remain activated (status:switched)

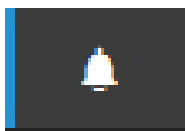

INVERTER Log Section

In the **INVERTER Log** Section it's possible to view the Alarm and Warning events list that it can be custom filtered by type or by entering a matching word.

Clicking on any event to view his details.

Alarm History

CLEAR FILTERS
REFRESH EVENTS

All
Fault
Warnings
Info

1 of 1

Origin: inverter	23/02/2017 16:23:56
△ W004 WARNING (CLOSED) AC GRID OVERVOLTAGE	
Origin: inverter	22/02/2017 19:01:11
△ W007 WARNING (CLOSED) AC GRID UNDERFREQUENCY	
Origin: inverter	22/02/2017 18:32:05
△ W022 WARNING (CLOSED) REACT POWER MODE CHANGED	
Origin: inverter	22/02/2017 17:10:05
△ W006 WARNING (CLOSED) AC GRID OVERFREQUENCY	
Origin: inverter	22/02/2017 16:23:56
△ W006 WARNING (CLOSED) AC GRID OVERFREQUENCY	

Event Details

Event Description

AC grid overvoltage - W004 - WARNING

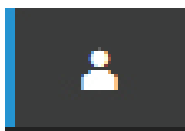

USER section

In the **USER** section it's possible to logout from Web User Interface and return to the login page, or to access the following sub-menus:

- **Edit Email and Password**
- **Admin Plus**
- **User Management**

Edit Email and Password

In the **Edit Email and Password** sub-menu you can change the e-mail and password related to the user which is used to login to the Web User Interface:

Admin Plus

By accessing to the **Admin Plus** sub-menu you can obtain the “Admin Plus” user privileges which allow you to:

- Change the grid standard of the inverter, after 24 hours while the inverter is operating (so the **Country Standard** sub-menu on **TOOLS** section is locked).
- View and edit the **AC Settings, Reactive Power Control, Ramp Control, Active Power Control** and **Frequency Control: P(f)**
- View and edit the “**MPPT Noise amplitude**” field in **DC Settings** on **SETUP** section.

To access on the Web User Interface with the “Admin Plus” user privileges it's required to enter a security token that can be obtained by registering on the website <https://registration.solar.fimer.com>. Refer to the dedicated section on this topic in the manual.

User Management

By accessing to the **User Management** sub-menu it's possible to edit all the users already created and create new users (both with admin or User privileges).



Connectivity section

In the **CONNECTIVITY** section it's possible to access the following sub-menus:

- **RS485**
- **LAN**
- **WLAN**
- **Modbus**
- **Debug Settings**

RS485

In the **RS485** sub-menu it's possible to adjust the settings relating to the RS485 communication serial line:

- **RS485 Node Address**: It allows you to set the address for serial communication of the individual inverters connected to the RS485 line. The UP and DOWN buttons scroll through the numerical scale. (The addresses that can be assigned are 2 to 63).
- **RS485 Baud Rate**: It allows you to set the Baud Rate (2400/4800/9600/19200/38400/57600/115200).
- **RS485 Parity Mode**: It allows you to set the Parity bit (No Parity, Even Parity, Odd Parity).
- **RS485 Protocol Type**: It allows you to set the type of protocol to be used for the RS485 line.
 - "Modbus Sunspec Server": General purpose communication protocol to be selected to enable monitoring and control.
 - "Device Acquisition": Communication protocol to be used in case of connection in "Master" mode to external devices (like VSN800 weather station).



LAN

In the **LAN** sub-menu it's possible to view the status and change the daisy chain configuration of the two ethernet ports of the inverter.

- Daisy chain configuration: DHCP or Static:

By selecting the DHCP function (default setup) the router will automatically assign a dynamic IP address to the inverter whenever it tries to connect to the user network.

With Static, the user can assign a fixed IP address to the system. The data which has to be entered in order for IP static address assigning to take place will appear. Complete the additional fields at the bottom of the screen (all the fields are mandatory with the exception of the secondary DNS server).

LAN Status

Daisy Chain

Linked interfaces:	ETH0, ETH1
IP Address:	10.21.39.51
Subnet Mask:	255.255.252.0
Gateway:	10.21.36.1
Primary DNS:	
Secondary DNS:	

Daisy chain configuration:

IP Settings

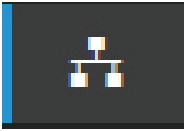

WLAN

In the **WLAN** sub-menu it's possible to view the status of the two wireless channels of the inverter, and to disconnect the channel 2.

- Channel 1: "Access Point mode": Only local communication is enabled in this mode; In particular, the WLAN acts like an «access point» generating a wireless network to which the user can connect locally, configure the inverter / photovoltaic system, using the direct access to the embedded Web User Interface

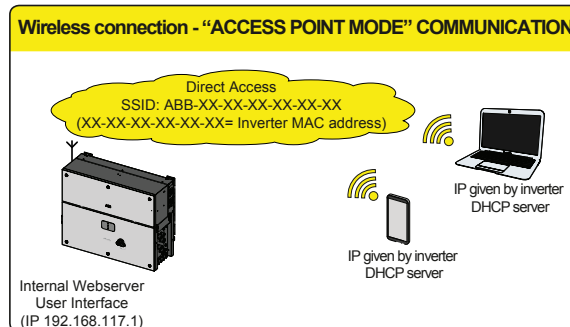

- Channel 2 "Station Mode": In this operating mode is possible to connect the inverter to a Wireless router; in this condition remote monitoring is enabled accessing to Aurora Vision® CLOUD platform.

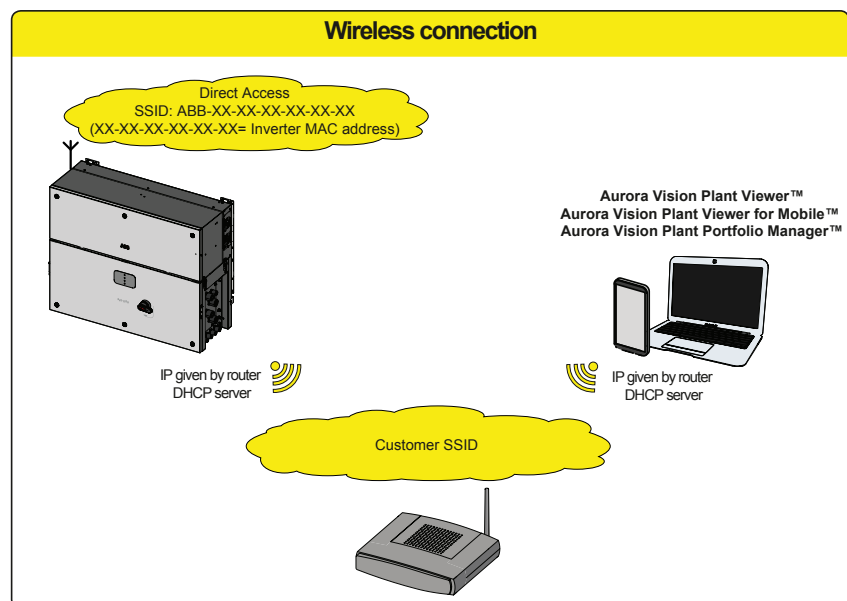



In case of connection to channel 2 (“Station Mode”), it will be required to enter the wireless network parameters (set on the router) and follow the subsequent procedure:

WLAN Status

Wireless channel 1

Mode: Access Point
 Status: **on**
 SSID: ABB-b0-72-bf-9f-0d-39
 IP: 192.168.117.1

Wireless channel 2

You are connected through the channel 2 (Station)

Mode: Station
 Status: **connected**
 Connected to: ((Power-One_Internal))
 Signal level: Strong
 IP: 10.21.43.188
 Netmask: 255.255.252.0
 DNS:
 Gateway: it-r-valwifidci

i Connect through the AP channel to change the connection status or the configuration of the station channel

DISCONNECT

Edit channel 2 configuration

IP Settings

DHCP

Available Network (SSID)

((Power-One_Internal))

Password

password

Show password

Back

Switch to AP

- IP Selection Mode: DHCP or Static:

By selecting the DHCP function (default setup) the router will automatically assign a dynamic IP address to the inverter whenever it tries to connect to the user network.

With Static, the user can assign a fixed IP address to the system. The data which has to be entered in order for IP static address assigning to take place will appear. Complete the additional fields at the bottom of the screen (all the fields are mandatory with the exception of the secondary DNS server).

- SSID (name of wireless network):

Identify and select your own (home) wireless network from all those shown in the SSID field (you can carry out a new search of the networks that can be detected with the Update button ). Once the network has been selected, confirm.

- Password (wireless network password):

Enter the password for the destination network (if necessary) and start the connection attempt (it will take a few seconds).

Click on “Connect”



Please do not close this page and waiting a moment

 **Config initializing**

Please wait the network initialization before change to new network



Once the inverter is associated with a wireless network, the user must switch the tablet/smartphone/PC to the same wireless network which the inverter is connected.

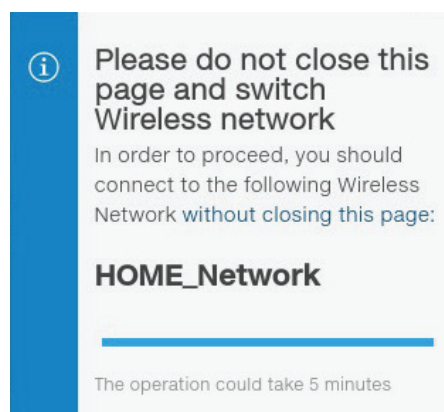

Once the tablet/smartphone/PC device is switched to the local wireless network a new message will confirm that the connection is acquired.

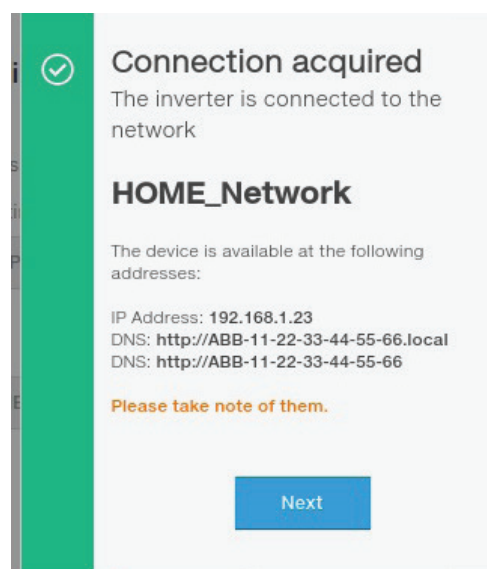

Click the “Next” button” to complete the setup of “Station Mode”



In order to use the “Host Name” as an alternative to the dynamic IP address, the Wireless router to which the board is connected (when operating in “Station Mode”) must provide the Domain Name System (DNS) service (contact the network administrator for further information regarding the presence or absence of the DNS service in the Wireless router or how to enable it). In this way, even if the IP address assigned to the inverter should change over time, (dynamic IP), it will always be possible to use the same “Host Name” which will remain unchanged over time.



The IP address assigned may vary for reasons connected to the wireless home router setup (for example, a very brief DHCP lease time). If verification of the address is required, it is usually possible to obtain the client list (and the corresponding IP addresses) from the wireless router administration panel.



Modbus

In the **Modbus** submenu it is possible to set the RTU inverter communication mode (RS485):

- type the "Edit" key and select the type of external device
- According to the device, select the communication protocol of the inverter

Moreover in the TCP / IP (WLAN / LAN) section there are different settings based on the type of external device connected to the inverter.

- If the inverter acts as CLIENT and the external device as SERVER:
 - type the "Edit" key and select the type of external device
 - According to the device, select the communication protocol
 - type in the [+] key and the added device is displayed
 - change the STATE / SLAVE ID / NAME / IP ADDRESS / PORT / DEVICE settings and save them.
- If the inverter acts as a SERVER, set the port communication protocol only (Communication protocol server)

Setting up communication over TCP/IP

[Edit WLAN](#)
[Edit LAN](#)

Communication protocol Server Sunspecs Protocol

Enabling monitoring of devices connected over Local Area Network

Used port

Add device -- Please select --

STATE	SLAVE ID	NAME	IP ADDRESS	PORT	DEVICE
<input type="button" value="Edit"/>					

Setting up communication over Serial Ports

RS485 Main - Node Address 1, Modbus SunSpec Server, 19200 bps, No Parity [Edit RS485](#)

Enabling monitoring of devices connected over Serial Ports

Operating mode Modbus SunSpec Server

To add a device you should switch to device acquisition operating mode

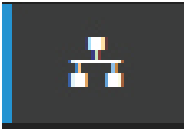

Debug Settings

In the **Debug Settings** sub-menu it's possible to enable or disable the Debugging access for FIMER Service purposes.

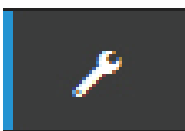

SERVICE Tools section

In the **SERVICE Tools** section it's possible to access the following sub-menus:

- **Country Standard**
- **Firmware Update**
- **Date/Time**
- **Connectivity Check**
- **Reset Manufacturing**

Country Standard

By accessing to the **Country Standard** sub-menu you can modify the grid standard within 24 hours while the inverter is operating.



*After the grid standard was set you have 24 hours to make any changes to the grid standard value; 24 hours later the **Country Standard** sub-menu will be locked, and any subsequent changes can only be made accessing with **Admin Plus** privileges. Refer to the dedicated section on this topic in the manual to know how to unlock the **Country Standard** sub-menu.*

Country standard

ⓘ You can change the parameter in the first 24 hours if you logged in as admin. After this time, you can reset the 24 hours only if you logged in as admin plus

Grid Standard

CEI 021 - internal protection ▼

RESET
SAVE

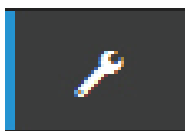

Firmware Update

By accessing to the **Firmware Update** sub-menu you can upgrade the firmware of the inverter and his components selecting a Remote firmware Update or a Local firmware Update.



Perform the update during good irradiation conditions (avoid the dawn and dusk hours). An interruption of updating process could damage the inverter!

←
Remote FW Update

You can update the inverter connecting to Aurora Vision. The procedure may take several minutes.

Remote
Local

Inverter

Current Firmware Release
----- - 0.8.2

Available Release
none - 0.8.3

UPDATE

• Remote firmware Update:

- In remote mode, the firmware will update automatically, searching the last available firmware on FIMER servers, by clicking the “CHECK” button.

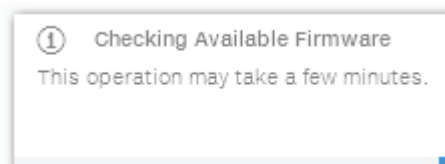

- After the finish of the checking process the available release will be notified on the bottom part of the section
- Click on “UPDATE” button to start with the updating process.

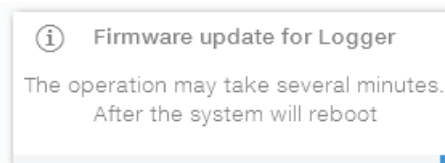

• Local firmware Update:

By updating in local mode, the firmware have to be selected and uploaded from local folder of the used devices to access to the web server.

The latest firmware version is available from the download area of the website www.fimer.com or from <https://registration.solar.fimer.com>

- Click on “FW SELECT” and select the firmware package previously downloaded.

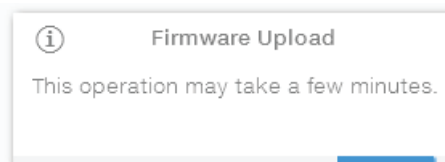

- Click on “UPDATE” button to start with the updating process.

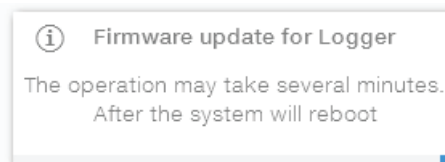

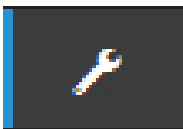

Date and Time

In the **Date and Time** sub-menu it's possible to set the date, time and time zone.

The inverter will propose these fields when the time protocol is available.

When it's not possible for the inverter to detect the time protocol, these fields have to be manually entered.

Date and Time

✔ Network Time Protocol server has been detected and it will be used to keep the system clock synchronized.

Date ✔

Feb 22, 2017

SET by the NTP server

Time ✔

4:52 PM

SET by the NTP server

Time Zone

Europe/Berlin GMT+01:00 ▼

SAVE



Connectivity Check

In the **Connectivity Check** sub-menu it's possible to carry out connectivity tests of the wireless network connection, ethernet connection, connection to Aurora Vision and firmware upgrade servers.

At the end of the test it will be reported the detail of the results.

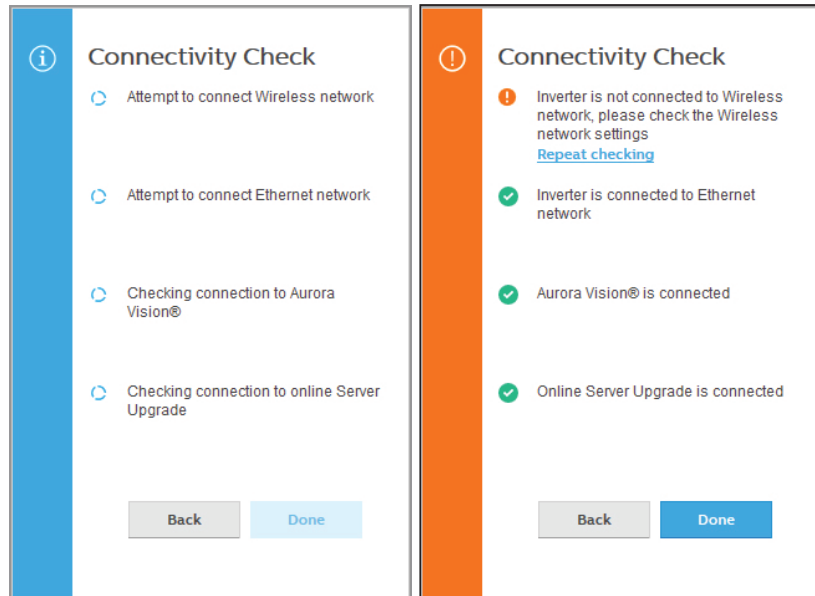

Reset Manufacturing

In the **Reset Manufacturing** sub-menu it's possible to reset the country standard, restore parameters to default and connectivity reboot.



INFORMATION Section

In the **INFORMATION** Section it's possible to view the general informations about the embedded Web User Interface.

it's possible to access the following sub-menus:

- **Product Info**
- **Privacy Policy**
- **Provider Information/Impressum**
- **Acknowledgments**
- **Release Notes**

General conditions

Routine and periodic maintenance operations must only be carried out by specialized staff with knowledge of how to perform these tasks.



Some inverter parts may be subject to voltages that could be hazardous for the operator. Before performing any work on the inverter, refer to “Inverter total de-energization and safe access” chapter on this manual to know all the necessary steps to safely operate on the inverter.



*For cleaning, DO NOT use rags made of filamentary material or corrosive products that may corrode the equipment or generate electrostatic charges.
Avoid temporary repairs. All repairs should be carried out using only genuine spare parts.
The maintenance technician is to promptly report any anomalies.*

DO NOT allow the equipment to be used if problems of any kind are found.



Always use personal protective equipment (PPE) provided by the employer and comply with local safety regulations.

Inverter total de-energization and safe access

The purpose of this chapter is to provide instructions for de-energize the PVS-100/120-TL inverters in order to allow access to active parts inside the inverter. The procedure describes the steps to perform a total isolation and thus includes operations on devices that are located outside the inverter. The total isolation approach consider **the disconnection of the inverter from any possible voltage source to which the inverter may be connected**. In the procedure the test of residual voltage potentially present inside the inverter is included. This procedure is intended exclusively to be used by skilled or trained persons in accordance with safety standards EN 50110-1 and EN 50110-2 (CENELEC/CEN) or equivalent standards. Furthermore, only these skilled or trained persons are permitted to carry out the procedure.

Operator and maintenance personnel skills/prerequisites



Personnel in charge of using and maintaining the equipment must be skilled for the described tasks and must reliably demonstrate their capacity to correctly interpret what is described in the manual.



For safety reasons, the installation must be performed by qualified installers and/or licensed electricians in accordance with the existing regulations in the country of installation and in accordance of all safety rules for performing electrical works. The installers must have demonstrated skills and knowledge of the inverter's structure and operation.



Inverter operation and maintenance by a person who is NOT qualified, is intoxicated, or on narcotics, is strictly forbidden.



The customer has civil liability for the qualification and mental or physical state of the personnel who interact with the equipment. They must always use the personal protective equipment (PPE) required by the laws of the country of destination and whatever is provided by their employer.

The following job requirements and qualifications are required to operate on the inverter:

- Compliance with all legal standard in force in the installation country to perform the electrical work described on this procedure.

Clothing and protection of personnel

The following Personal Protective Equipment (PPE) are required to perform any intervention on the inverter:

- Insulating composite gloves class 0 EN60903 (1000Vac-1500Vdc) resistant to electric arc class 2 (7kA) EN61482-1-2 in combination with protective overglove in leather EN420 – EN388.
- IEC Class 1 (8 cal/cm²) basic arc-flash protection wear, combined with IEC Class 2 (25 cal/cm²) overall arc-flash protection.
- IEC Class 2 (40 cal/cm²) arc-flash protection for head (archood) with helmet included.
- Safety shoes (ISO 20345:2011).

Safety equipment and tools

The following equipment and tools are required to perform any intervention on the inverter:

- Disconnect tool for DC side (PV) connectors.
- Voltage detector (EN 61243-2) capable of 3kVdc and up to 1kVac.
- DC current clamp.
- Multimeter (only for DC fuse testing and verify absence of short circuit)
- Safety tags “work in progress, do not operate”.
- Padlocks.
- Grounding kit AC

Inverter total de-energization and safe access procedure

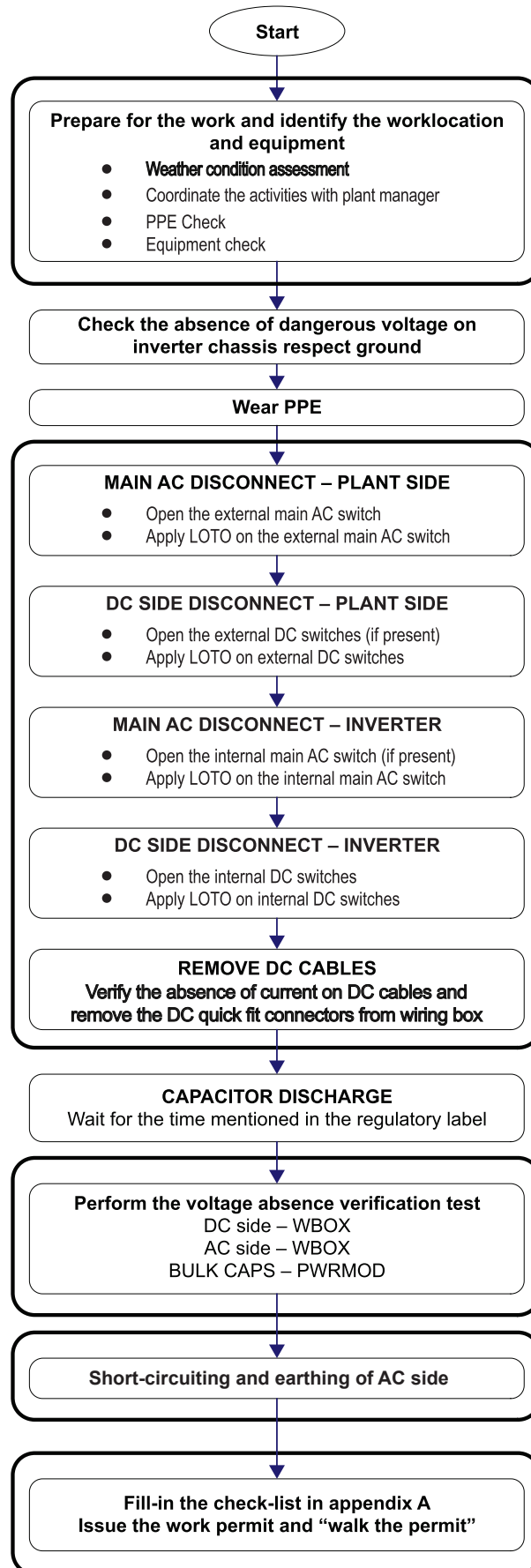



When the device has just been switched off, it may have hot parts as a result of overheating of the heated surfaces (e.g.: transformers, accumulators, coils, etc.) so be careful where you touch.



Some inverter parts may be subject to voltages that could be hazardous for the operator. Before performing any work on the inverter, follow this procedure for safely isolate the inverter.

1. Preliminary checks

- Weather conditions: In the risk assessment prior the intervention it is of paramount importance to evaluate the weather conditions. This procedure can be applied only in case of dry environment. Don't proceed in case of rain (even light) or high humidity.
- PPE Check: Verify the integrity of the PPE that is going to be used to perform the operations.
- Equipment check:

Check the voltage tester is working correctly:

- Perform an integrity check of the instrument in general; examine the test terminals, its integrity and make sure they are properly fixed; make sure the batteries level is enough high (don't use the instrument in case the message "LOW BATTERY" is present) or replace them.
- Perform test of the instrument using an energized AC socket and a DC voltage source (example: battery in the service car) with known voltage level; in case the instrument is provided with a self-test feature, follow the instructions provided in the instrument manual to carry out the self-test.

Check the voltage tester is working correctly:

Check the DC current probe is properly working, make sure to perform the "ZERO-OFFSET" procedure and to select DC measurement range.

2. Wear the appropriate PPE for carrying out the operations (see "Clothing and protection of personnel" paragraph of this procedure).



All the following activities (till the completion of the procedure) must be performed wearing the PPE

3. Check the absence of dangerous voltages on inverter enclosure respect ground:

- Check the absence of dangerous voltage on the inverter chassis. The measurement point are between inverter chassis (both power module 01 and wiring box 02) and the Protective earth point (ext.) 10 outside the inverter.

4. Operations on External AC switches

The below diagrams represents a possible arrangement of the PV plant. Depending on the design choices made by the developer of the plant some of the devices could not be present.



Identify the external AC switch(es) in the plant with the support of the plant manager. In case none of the LV AC switches are present, the MV switch must be opened.

- Open the external AC disconnect switch or the main external AC disconnect switch (in blue in the picture) outside the inverter (IEC 60364-7-712.536.2.2). In case none of the LV AC switches are present, the MV switch must be opened.

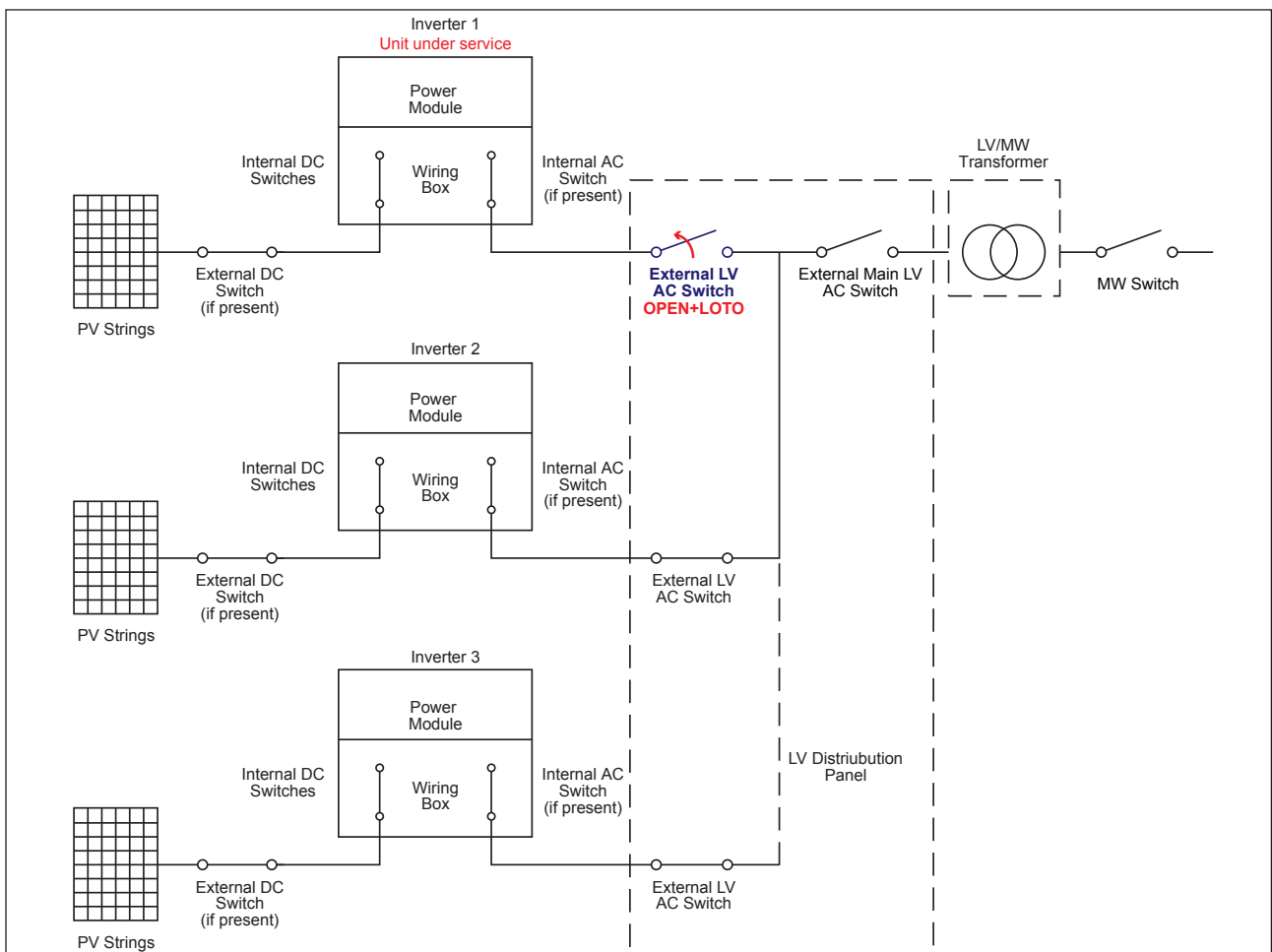

- Affix padlocks to prevent operation onto any external AC disconnect device. Affix designated tags (LOTO procedure).



Identification of the external switch may require the cooperation of the plant manager and it must be included in the switching plan defined during the preparation of the work.

- Check on the LED panel 08 the shutdown command has been carried out (Missing Grid status):
 - **Power** LED (Green): Flashing
 - **Alarm** LED (Yellow): ON (solid)
 - **GFI** LED (Red): OFF
 - **WLAN/LAN** LED (Blue): Depends by the communication status.

5. Operations on External DC switches (if present)



In case of absence of External DC disconnect device skip this step.

The diagram below represents a possible arrangement of the PV plant. Depending on the design choices made by the developer of the plant some of the devices could not be present. Identify the external DC switch(es) in the plant with the support of the plant manager.

- Open the external DC disconnect switch (in blue in the picture) outside the inverter (IEC 60364-7-712.536.2.2)

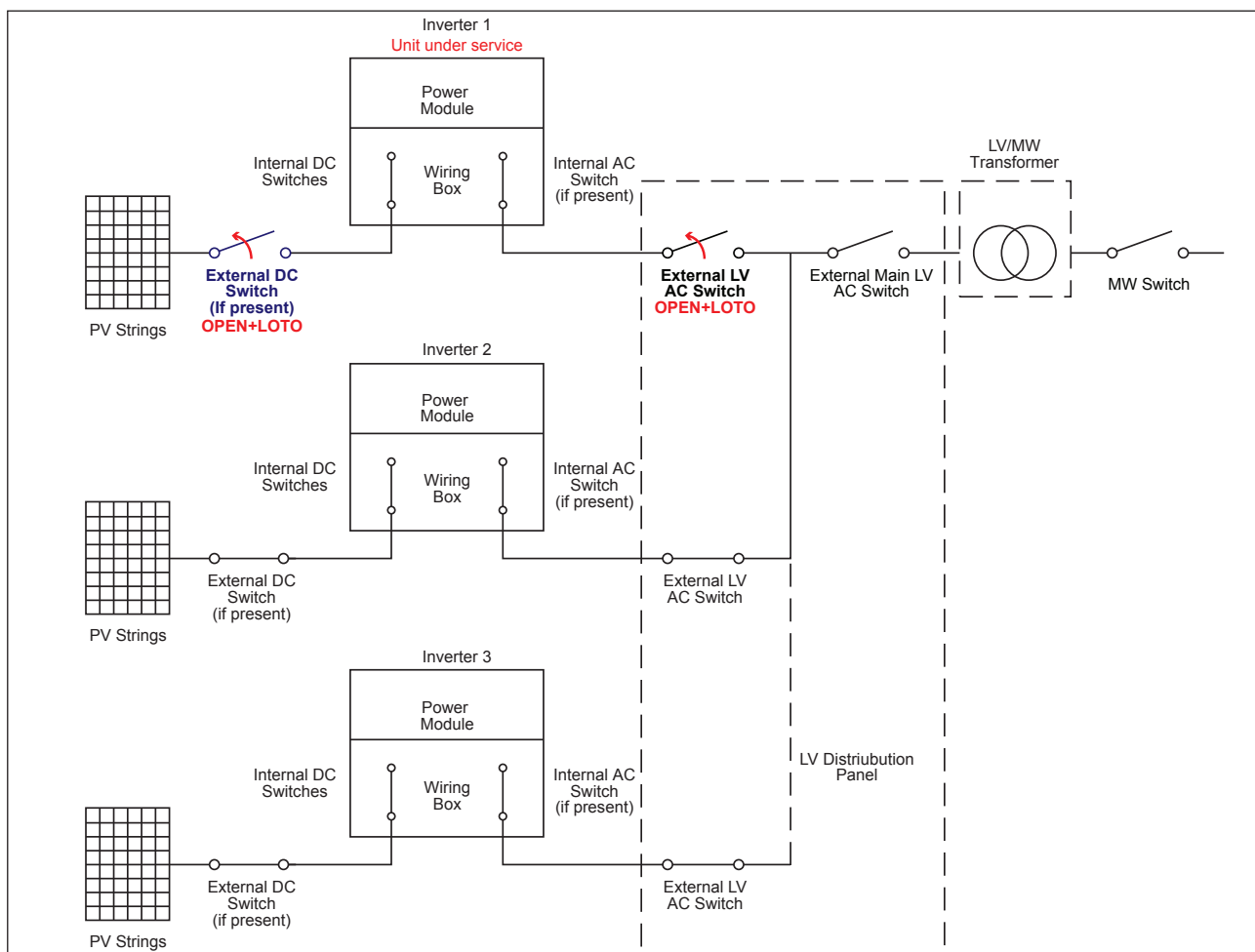

- Affix padlocks to prevent operation onto any external DC disconnect device. Affix designated tags (LOTO procedure).



Identification of the external switch may require the cooperation of the plant manager and it must be included in the switching plan defined during the preparation of the work.

- Check on the status LEDs **08** the shutdown command has been carried out (Missing DC voltage status): **All LEDs OFF**.



The time needed for the complete shut-down of the LEDs depends by the input voltage of the inverter. The complete shut-down of the LEDs may require some minutes.

6. Operations on internal AC disconnect Switch 09 (if present)



This operation can be done only in case of wiring box 02 SX2/SY2 model.
The wiring box 02 SX/SY model doesn't include the AC switch 09.

- Open the main AC disconnect switch 09 (shown in blue in the picture below).

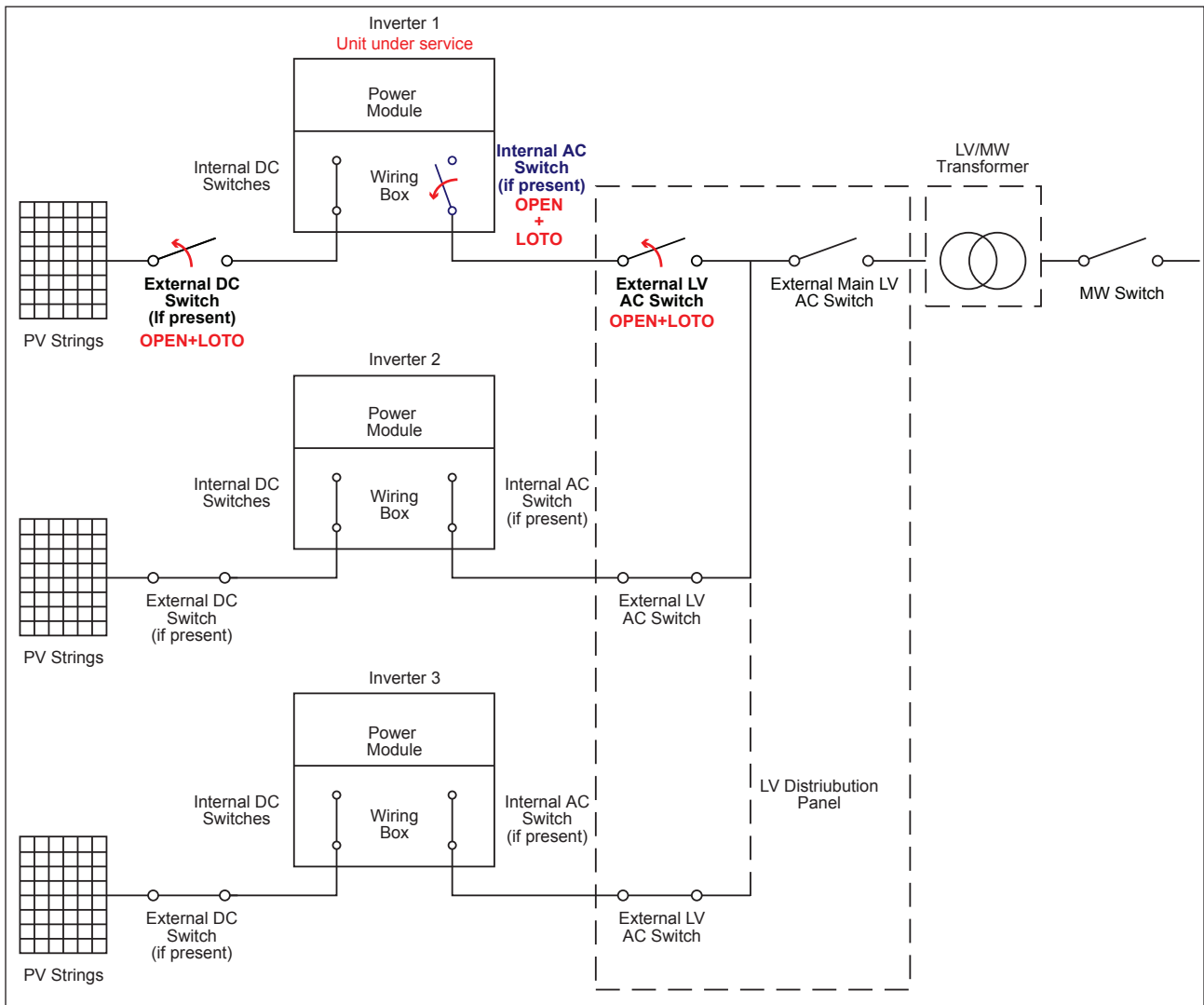

- Affix padlocks to prevent operation onto AC disconnect switch 09.
Affix designated tags (LOTO procedure).

7. Operations on Internal DC disconnect switches ¹⁵

- Open the two internal DC switches ¹⁵ (blue in the picture).

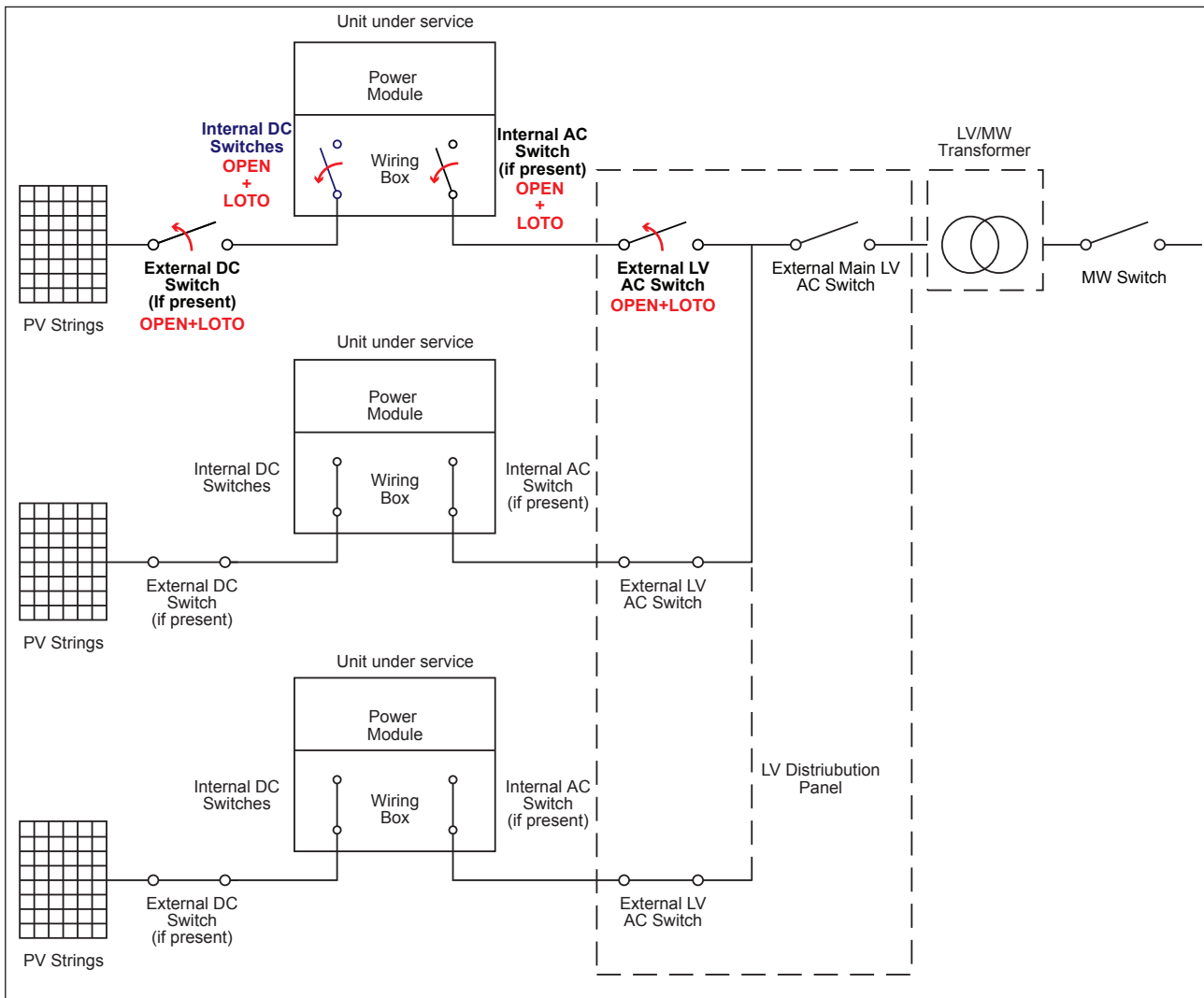

- Affix padlocks to prevent operation onto all DC disconnect switches ¹⁵. Affix designated tags (LOTO procedure).
- Check on the status LEDs ⁰⁸ if the shutdown command has been carried out (Missing DC voltage status): **All LEDs OFF**.



The time needed for the complete shut-down of the LEDs depends by the input voltage of the inverter. The complete shut-down of the LEDs may require some minutes.

The below picture represents the expected status of the switches in the plant after the switching operations have been completed.

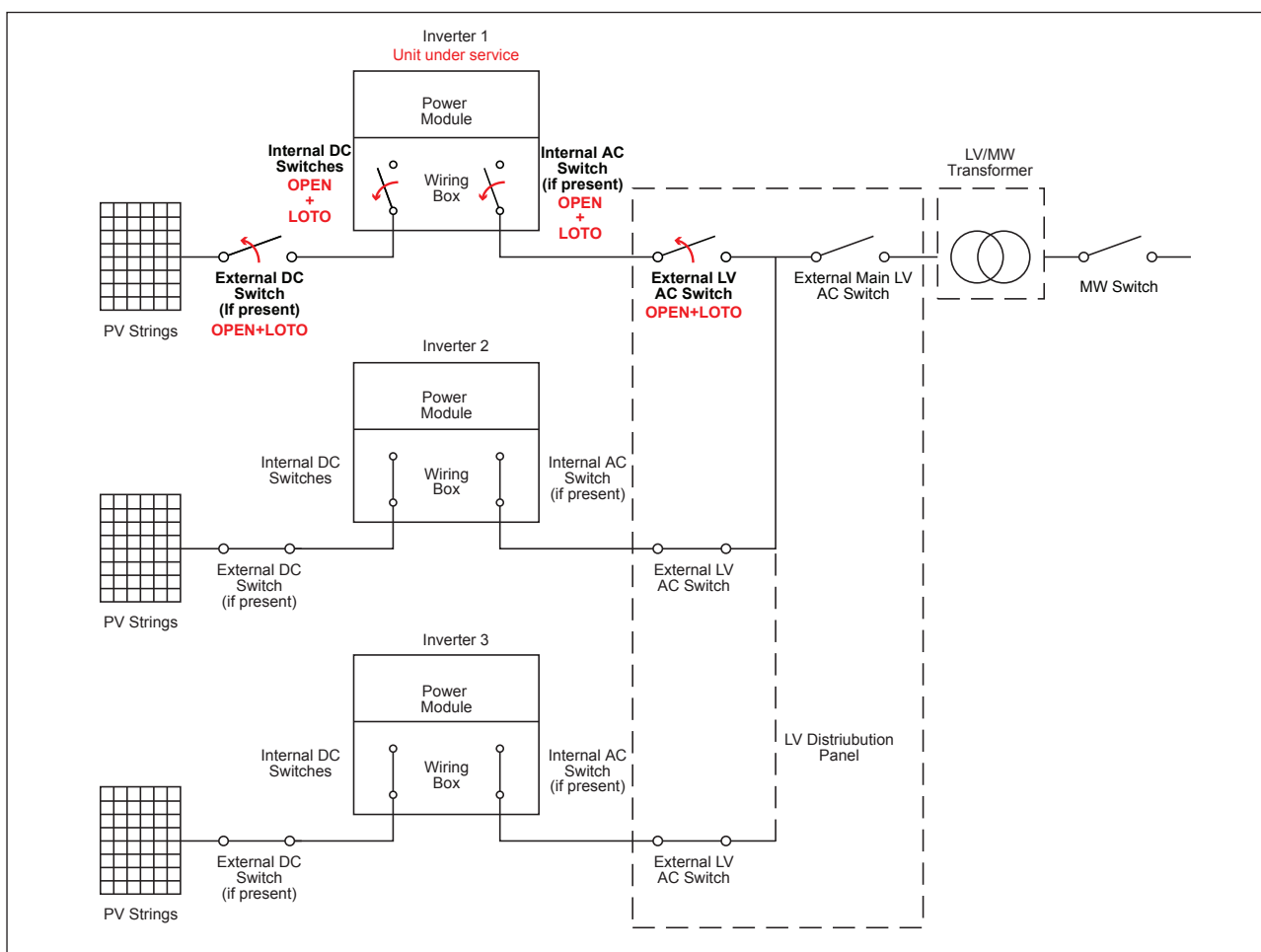

8. Remove the DC quick fit connectors **16** from wiring box **02**

- Using the current clamp check the absence of current on DC side, measurement each positive and negative DC input string cables (check the correct setting of the current sensor).
- Remove all quick fit DC connectors **16** (PV Connectors) from the wiring box **02**, using the dedicated disconnect tool. To avoid mechanical interferences, use a cable tie to collect the disconnected cables.

After the intervention, before reconnecting the quick-fit DC connectors in their counterparts, make sure about the followings (for each connection):

Checks related to the inverter:

For each input channel, verify the absence of short circuits between:

- positive and negative terminals
- positive and ground (PE) terminals
- negative and ground (PE) terminals

The test must be performed using multimeter (set to measure Ohm) by placing the multimeter's test point inside the inverter DC connectors, in the same points where the quick-fit DC connectors (coming from the strings) shall be reconnected.

Checks related to PV strings(*):

- Polarity: make sure the polarity is the correct one.
- Voltage: make sure the voltage is within the operating range of the inverter.
- Leakage: make sure no leakages are present on the strings.

(*) this check must be performed in case the safe access is done to repair the unit and there is the possibility the fault was induced by reversed polarity, voltage out of the allowed range, leakage to ground. About how to perform the tests, refer to product manual about the preliminary check to perform prior the connection of the strings to the inverter

9. Discharge of the capacitor

- Wait the internal capacitors to be discharged. The discharge time of the stored energy is indicated on the regulatory label.



The covers of the wiring box and of the power conversion box can be opened (to carry out the Voltage Absence Test, next step) only once the discharge time mentioned in the regulatory label is elapsed.

10. Voltage absence test on DC side (wiring box)

Before to approach the below operations all the steps from 1 to 9 included must be successfully completed.

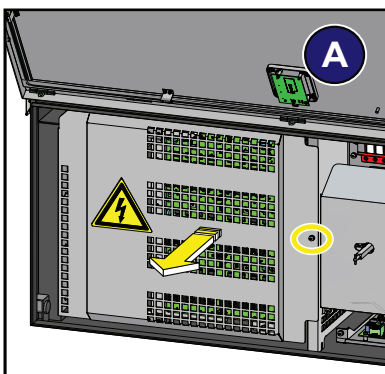

- Access to the wiring box 02 by opening the front wiring box cover 07.
- Remove the DC protective shield over the DC strings fuses plate 19 20.
- Visually inspect the components to identify the presence of any overheating, signs of electric arcs, failure of the insulating devices, loosen connections or cables not connected.
- Check all the LEDs installed on the DC Input Positive board are OFF.

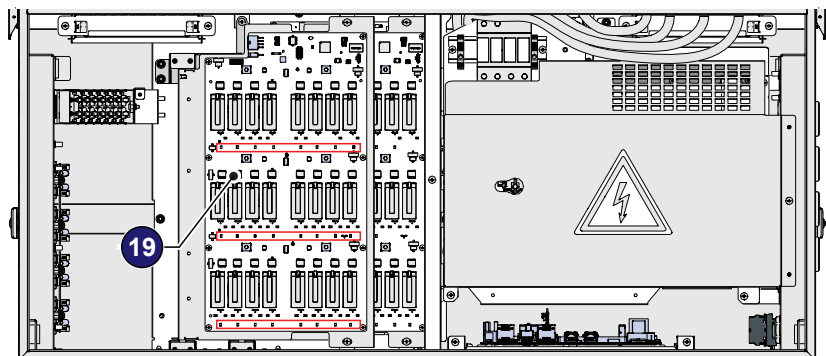

For each one of the input channels, the measurement must be performed between: positive to ground, negative to ground, positive to negative.

- Positive/Ground checks :

The points on the positive string fuses plate **19** where the input DC voltage absence test must be performed are shown in the below picture. Check the absence of voltage on the DC terminal block using the voltage detector. The check must be done using the voltage detector, wearing the PPE.

Check sequence: Positive to ground (PE)	
First point	Second point
CH1(+)	PE
CH2(+)	PE
CH3(+)	PE
CH4(+)	PE
CH5(+)	PE
CH6(+)	PE

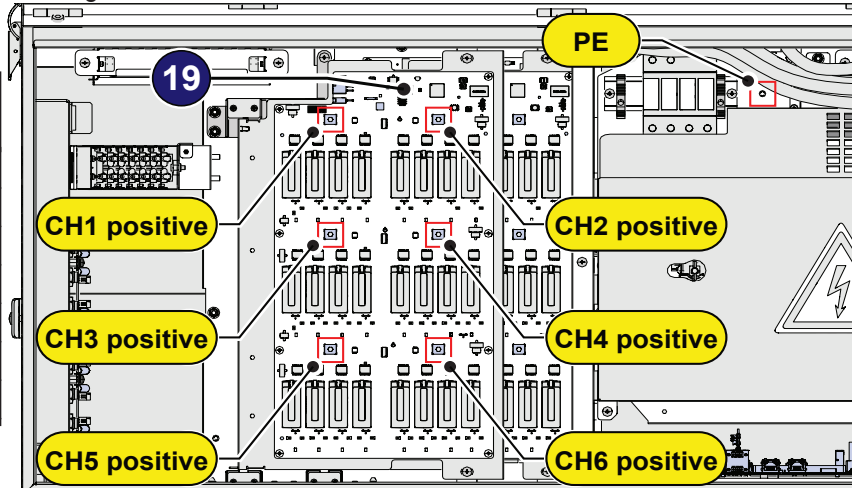

- Negative/Ground checks :

The points on the negative string fuses plate **20** where the input DC voltage absence test must be performed are shown in the below picture. Check the absence of voltage on the DC terminal block using the voltage detector. The check must be done using the voltage detector, wearing the PPE.

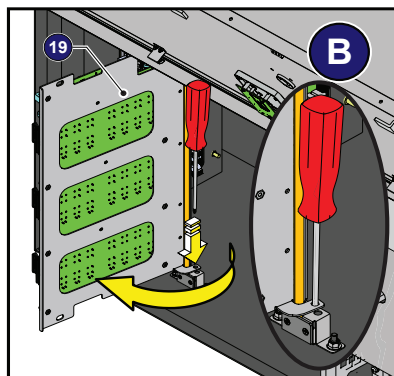

The DC Input negative board are located below the DC Input positive board. In order to access at this board you must remove two screw and open the positive metal plate by tilting it from the right to left side.

- Remove the two M5 screws from the positive string fuses plate **19**
- Tilt the positive string fuses plate and lock the open position of the positive string fuses plate with a screwdriver.

The points on the negative string fuses plate **20** where the input DC voltage absence test must be performed are shown in the below picture. Check the absence of voltage on the DC terminal block using the voltage detector. The check must be done using the voltage detector, wearing the PPE.

Check sequence: Negative to ground (PE)	
First point	Second point
CH1(-)	PE
CH2(-)	PE
CH3(-)	PE
CH4(-)	PE
CH5(-)	PE
CH6(-)	PE

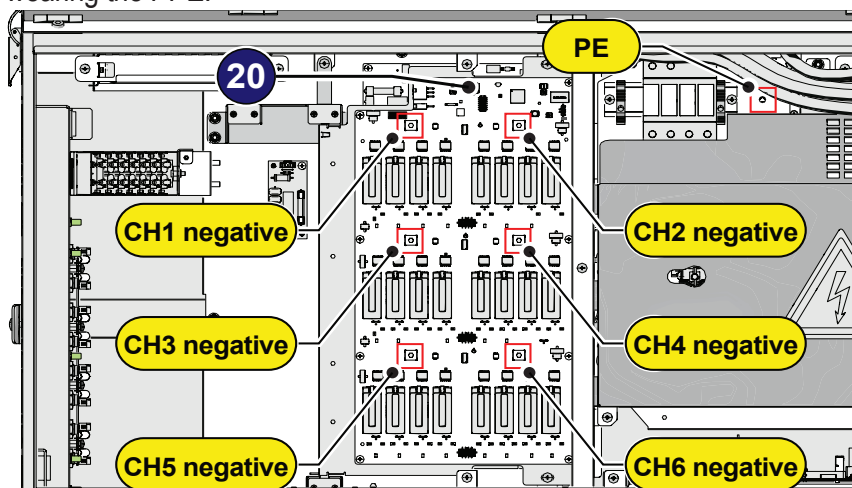

In case of absence of voltage (respect to the ground) check there is no voltage on the all DC branches coming from the photovoltaic field (using the voltage detector), measuring between the all points: CH positive / CH negative.

- Measure points on the positive string fuses board ¹⁹

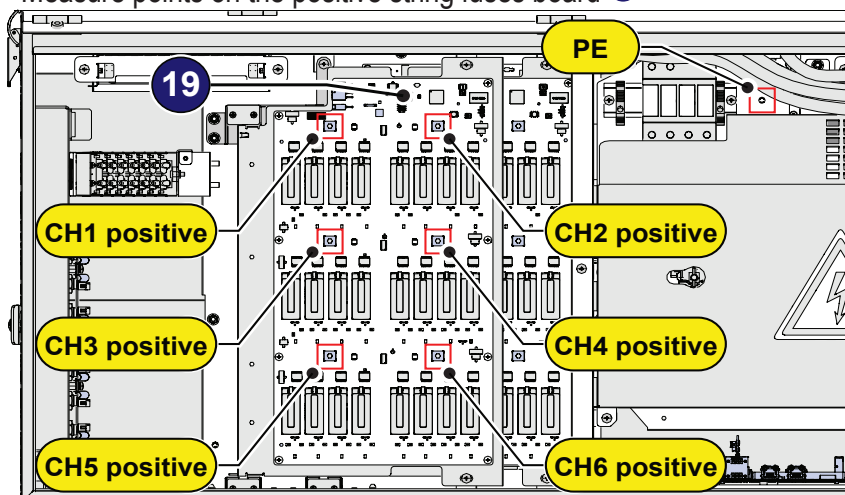

Check sequence: Negative to ground (PE)	
First point	Second point
CH1 positive	CH1 negative
CH2 positive	CH2 negative
CH3 positive	CH3 negative
CH4 positive	CH4 negative
CH5 positive	CH5 negative
CH6 positive	CH6 negative

- Measure points on the negative string fuses board ²⁰

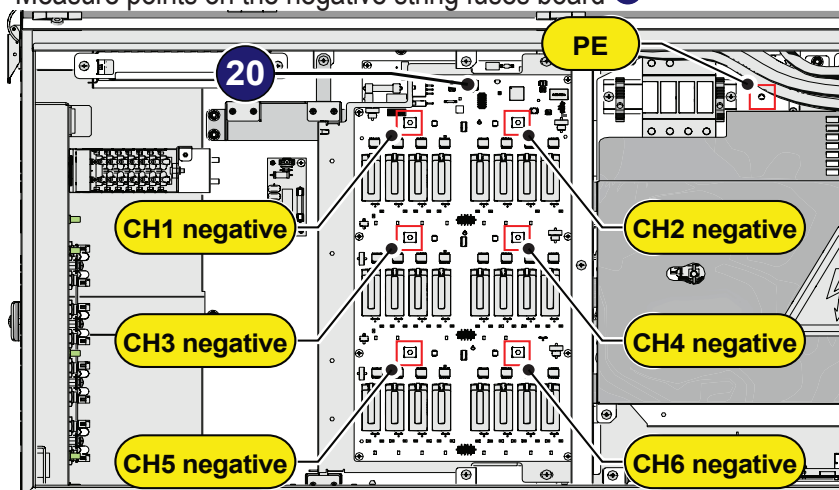

11. DC string fuses test



Before to carry out the following operations it is required to have successfully completed the voltage absence test on all the incoming DC line

Multimeter preparation

- Set the multimeter to measure resistance (Ω)
- Insert the black test probe into the COM jack.
- Insert the red test probe into the V/ Ω jack.
- Keep the multimeter's test probes separated: check the multimeter's display shows OL.
- Put in short circuit the test probes: check the multimeter's display shows 0 Ω .

Test the DC fuse

- Place the test probes across the fuse (positive and negative) to check
- The expected value is 0 Ω .

12. Voltage absence test on AC side (wiring box)

- Remove the AC protective shield **27** over the AC connection busbar **21** as shown in the picture.

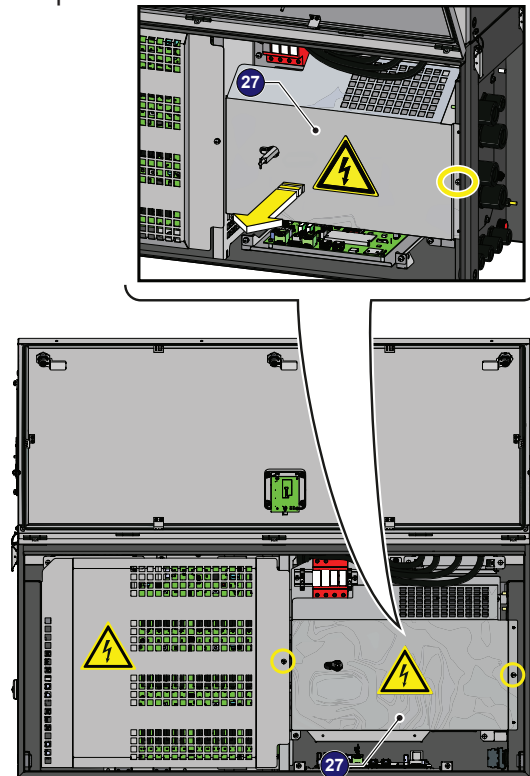

- Visually inspect the components to identify the presence of any overheating, signs of electric arcs, failure of the insulating devices, loosen connections or cables not connected.
- Check there is no voltage on the AC connection busbar **21** downstream of the AC breaker. Measuring between the all points (using the voltage detector) refer to table below.

Check sequence	First point	Second point
1° check	R	PE
2° check	S	PE
3° check	T	PE
4° check	N	PE
5° check	R	S
6° check	S	T
7° check	T	R
8° check	R	N
9° check	S	N
10° check	T	N

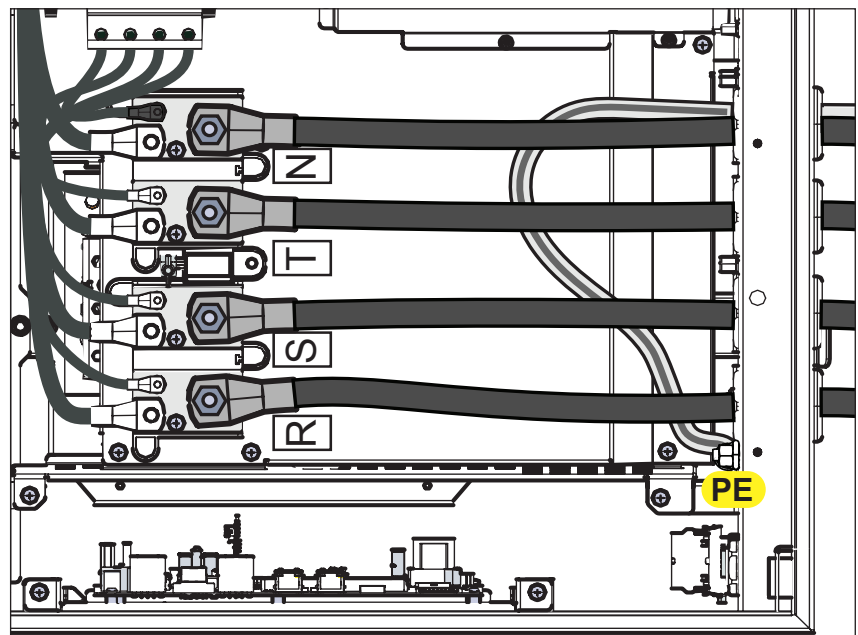

13. Voltage Absence Check on DC Bulk Capacitor



Wear the PPE. Refer to chapter 6 for the list of required PPE

- Access to the power module 01 by opening the power module front cover 54.
- Visually inspect the components to identify the presence of any overheating, signs of electric arcs, failure of the insulating devices, loosen connections or cables not connected.
- Check there is no voltage on the DC bulk. Measuring between the all points (using the voltage detector) refer to table below.

Check sequence	First point	Second point
1° check	VDC Bulk +	PE
2° check	VDC Bulk -	PE
3° check	Bulk +	Bulk -

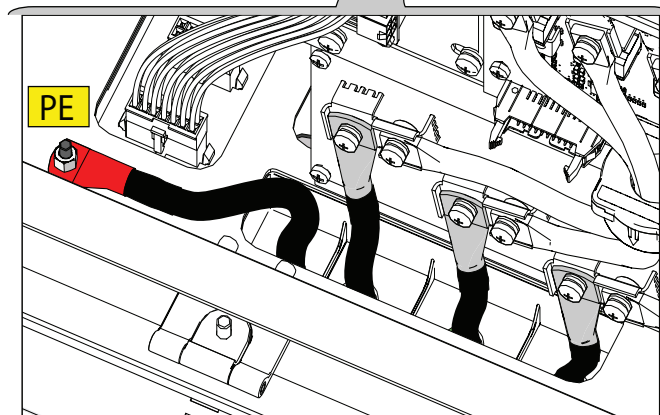
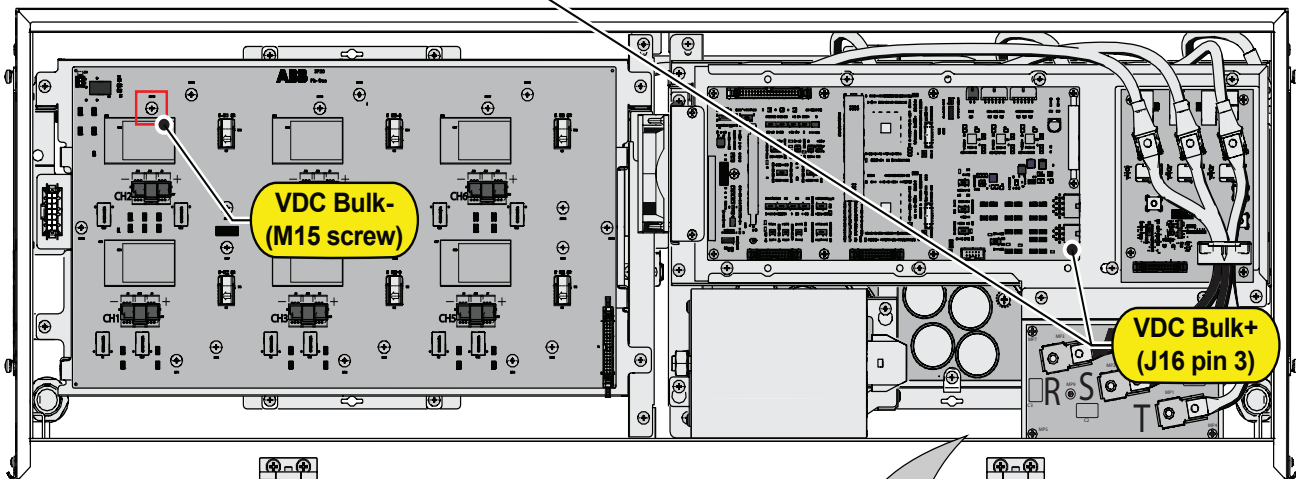
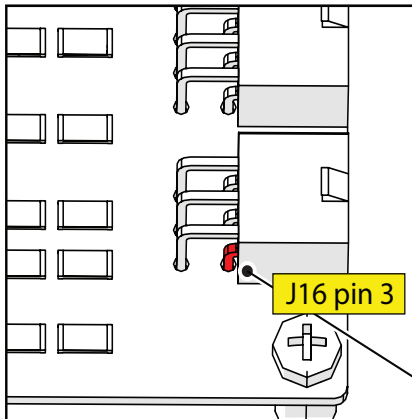

14. Grounding kit installation on AC side



The grounding kit installation is allowed only after completing all steps described in this procedure

- Install 4 Fixed Ball Points in the AC phase R-S-T and neutral N

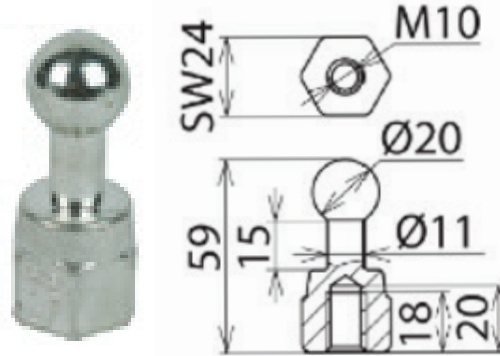
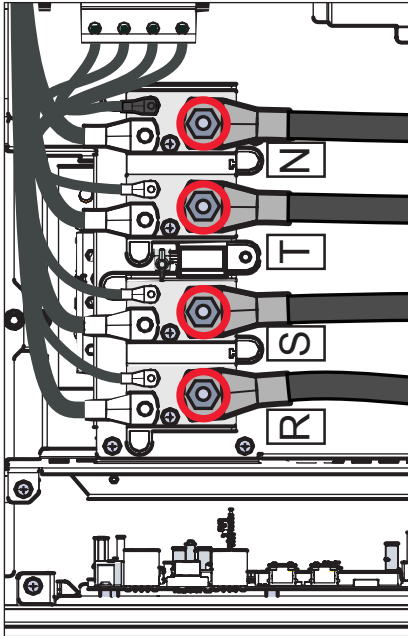

- Install the earth connecting elements to the earthing and short-circuiting cable

- Connect the earthing cable to the ground
- Connect the earth connecting elements on the fixed ball points, to put in short circuit and to ground the phase R-S-T and N.

15. Check list to be filled prior the access to the inverter

- Purpose of the checklist is to verify that all the operations mentioned in the procedure have been carried out. The checklist below must be attached to the intervention report.

CHECK	STATUS √ or X
Prepare for the work and identify the work location and equipment	
PPE and Equipment Check	
PPE wearing	
OPERATIONS AT PLANT LEVEL [*]	
Check the absence of dangerous voltages on inverter chassis respect ground	
Operations in External AC switch	
Operations in External DC Switch (If present)	
OPERATIONS AT INVERTER LEVEL	
AC disconnect - Inverter Side	
DC disconnects - Inverter Side (opening and LOTO of DC switches in all power compartments)	
Remove the DC cables from the terminal block	
Wait the discharge of the internal capacitor	
VOLTAGE ABSENCE TEST	
Voltage absence check on DC side	
Voltage absence check on AC Side	
Voltage absence check on bulk capacitors	
SHORT-CIRCUIT AND EARTHING	
AC grounding installation	
ISSUE WORK PERMIT	
Issue work permit and "Walk the permit" – Check list filling	
== ONLY if all checks are POSITIVE (√) the ACCESS IS ALLOWED =	

[*]: Identification of the external switch may require the cooperation of the plant manager and it must be included in the switching plan defined during the preparation of the work.

Routine maintenance

To preserve long term proper operation of the inverter, you are advised to perform the routine maintenance operations listed in this chapter.



Maintenance operations shall be performed only by qualified personnel or FIMER personnel (under a servicing contract). The maintenance schedule may vary depending on the environmental conditions of the installation.

Table: routine maintenance

Annual visual inspections		<ul style="list-style-type: none"> • Check that the inverter is operating properly, without any alarm signals. • Ensure all labels and safety symbols are visible. • Check the integrity of the cables, connectors and cable glands outside the inverter. • Check that the environmental conditions have not changed dramatically from those on installation. • Check there are no obstacles (animals, insects, leaves or anything which could reduce the heat exchanging capacity of the heat sink) at the top, at the bottom and between the fins.
Annual operations		<ul style="list-style-type: none"> • Check the tightening of the cable glands and the screw terminal blocks. • Check the front covers is secured. • If there is no monitoring system, check the record of alarms and errors using the indications provided in the manual in order to check recent notification of recent malfunctions. • For the models with AC disconnect switch, it is recommended that once a year the disconnect switch is operated a number of times (at least 10) to keep the contacts clean and prevent oxidation. This operation must be carried out in periods with low input power or at night.
Annual cleaning		<ul style="list-style-type: none"> • Clean the equipment; verify, in particular, clean the side and top arrays of the cooling fan assembly and the heat sink.



For a complete maintenance procedure ask for "Preventive Maintenance -Life Cycle" to FIMER customer service.

Troubleshooting



Operations on the inverter to identify and address any faults may only be performed by the installer or by qualified personnel.

Web User Interface and wireless communication troubleshooting

The following table gives a list of main and most common errors or problems relating to the wireless communication between inverter and user devices.

Problem	Possible causes	Solution
The Web User Interface cannot be accessed.	ADMIN or USER password forgotten.	Reset the passwords by clicking on "Forgot your password"; The passwords can be reset after having entered the "Product Key" code that can be found on the "Communication Identification Label".
The inverter is able to identify a wireless network but is unable to connect to it.	The signal between the inverter and the wireless router to which the board wants to connect is too weak.	Modify the position of the wireless antenna, the inverter or the router.
		Make sure that the inverter has not been installed near obstacles which could affect the communication with the wireless router (for example: metal cages or walls, walls in reinforced concrete, electromagnetic fields).
		Move the router as close as possible to the inverter.
The inverter is unable to connect to a wireless network.	The wireless network to which the inverter is to be connected, could require the user to enter a username and password to allow navigation (for example, with a public wireless network or a hotel).	Install a wireless signal repeater in order to extend the network to which the inverter is to be connected; then connect the inverter to the repeater.
		Unfortunately the inverter cannot be connected to these types of wireless networks. Connect the inverter to an alternative wireless network.
The Inverter has not identified the wireless network to which connection is required.	The wireless network to which the Inverter is to be connected, is set so as not to be identified (hidden network).	The Inverter is not able to connect to a hidden network. Set the wireless network to which the inverter is to be connected (visible network), then identify and connect the Inverter to the wireless network as normal.
		Modify the position of the wireless antenna, the inverter or the router.
		Make sure that the inverter has not been installed near obstacles which could affect the communication with the wireless router (for example: metal cages or walls, walls in reinforced concrete, electromagnetic fields).
The wireless board does not communicate correctly with the inverter inside of which it is installed (inconsistency in the detected data read by the board), or when working in "Access Point Mode", it's not possible to access the Web User Interface.	The signal between the inverter and the wireless router to which the board wants to connect is too weak.	Move the router as close as possible to the inverter.
		Install a wireless signal repeater in order to extend the network to which the inverter is to be connected; then connect the inverter to the repeater.
The wireless board does not communicate correctly with the inverter inside of which it is installed (inconsistency in the detected data read by the board), or when working in "Access Point Mode", it's not possible to access the Web User Interface.	The wireless board of the inverter could be damaged.	Request a service intervention to check that the inverter wireless board is working correctly.
	Wrong Inverter Date/Time settings.	Check if Date/Time has correctly set on the inverter; correct it if necessary.
Alternating difficulties in the local connection to the Web User Interface.	The inverter might not be correctly powered (for example, if the inverter is switched off at night, the Web User Interface cannot be accessed).	Access to the Web User Interface only when the inverter is correctly powered.
	The wireless connection signal between the device in use and the router or the Inverter, may not have sufficient power or it may be disturbed by obstacles which affect the communication.	Make sure that the signal between the wireless devices which interact with the inverter are sufficiently high and that any obstacles such as metal cages or walls, walls in reinforced concrete or strong electromagnetic fields do not affect communication.







Problem	Possible causes	Solution
Although the Inverter has been configured correctly in "Station Mode" and works correctly on the local network, no data has been transmitted to the Aurora Vision®.	The MAC address used to register the inverter on the Aurora Vision® platform is not the same as the actual address associated with the inverter.	Make sure that the MAC address registered on the Aurora Vision® platform is actually the one associated with the inverter. If it is not, modify the registered MAC address.
	The wireless network to which the Inverter is connected, could be protected by a Firewall which prevents the remote exchange of data with the Aurora Vision® platform.	Contact the network administrator in order to have the Firewall configured so that the remote exchange of data between the Inverter and the Aurora Vision® platform is allowed.
It is not possible to access the Web User Interface using the IP address when the inverter is operating in "Station Mode – DHCP".	An incorrect dynamic IP address is being used to access the Web User Interface or the IP address could have been modified by the wireless router to which the inverter is connected.	Access the Web User Interface using via "AP Mode" (refer to dedicated section to know how to connect via "AP Mode") and read the current IP Address in "NETWORK > WLAN" section.
	The IP Address used to access the Web User Interface was lost.	Access the Web User Interface using the "Host Name" that could be obtained writing this url http://ABB-XX-XX-XX-XX-XX-XX.local replacing the "X" with the hex digits of the MAC address of the inverter (it can be found on the "Communication Identification Label" placed on the side of the inverter or applied during the commissioning phase to the plant documentation). The DNS or multicast service must be enabled on router. Note: This connection method doesn't work on Android devices.
	If possible, access the pages of the wireless router web server to which the inverter is connected and read the new dynamic IP address assigned to the Inverter.	
	The wireless router doesn't allow the connection to local IP address. Typically this happen on company networks.	Contact the network administrator to allow the wireless router to connect to local IP address.
	The device doesn't allow the connection to local IP address. Typically this happen with company devices.	Contact the system administrator to allow the device to connect to local IP address.
Using an Android devices, a notification advise that internet connection is missing when trying to connect to the Access Point wireless network created by the inverter and ask for connection confirmation.	Known behavior of Android devices. Android OS always check if internet connection are available and ask for confirmation if it's not present.	Confirm the connection request in the notification of Android devices by clicking "Yes".

Alarm Messages of the Inverter













In order to understand and resolve warning (Wxxx) or error (Exxx) signals that appear in the Event or Dashboard section of the Web User Interface follow the table given in the following paragraph.











The equipment can notify errors/warnings in the Event or Dashboard section of the Web User Interface only if the input voltage is greater than the Vdcm voltage (POWER Led flashing or lit; see chapter on operation).









The following table gives the complete list of errors/warnings relating to string inverters. Some error/warning codes may not be used depending on the inverter model installed.

- Error code - Error message - LED status	Name of Alarm and Cause	Solution
- No code - Ground F -  Red LED	Ground fault of photovoltaic generator: The alarm is generated when a leakage current to ground is detected in the DC section of the system.	<ul style="list-style-type: none"> • Measure the isolation resistance using a megohmmeter positioned in the photovoltaic array (positive terminal short-circuited at the negative pole) compared to ground. The measurement is strongly influenced by the environmental conditions, so must be made under the same conditions in which the error occurred. - If the value measured is lower than 1 megaohm, a check must be carried out by a technician/installer on the photovoltaic generator to identify and eliminate the problem. - If the value measured is higher than 1 megaohm and the error signal persists, contact customer assistance.
- No code - Missing Grid -  Flashing green LED -  Yellow LED	Missing Grid: The inverter does not detect grid voltage (AC side).	<ul style="list-style-type: none"> • Check the grid voltage on the inverter's AC terminal block. - Should it be absent, check any protection work on the line and the presence of grid voltage on the supply point.
- No code - Memory fault -  Flashing yellow LED	Memory fault: The inverter has detected a communication problem with the memory board on which the inverter saves the daily value of energy produced.	<ul style="list-style-type: none"> • Remove the memory board and check the welding of all the connector's terminals. Subsequently reinsert the memory board and check that it is correctly inserted into the dedicated slot - If the signal persists also following the above checks, contact customer assistance.
- No code - Waiting Sun -  Flashing green LED	Waiting Sun: The inverter goes into the "Waiting Sun" stage when, following a W001 and/or W002 warning, the voltage from the photovoltaic generator is less than the activation voltage (Vstart).	<ul style="list-style-type: none"> • Check the input voltage on the inverter. - If it does not exceed Vstart, check for the presence of sufficient irradiation and the correct composition of the system. - If it exceeds Vstart, contact customer assistance
- W001 - Sun Low -  Yellow LED	Insufficient irradiation (Low input voltage on switching on the inverter): Incorrect configuration of the PV generator or an "on the limit" configuration for the inverter's minimum input voltage.	<ul style="list-style-type: none"> • Check the input voltage on the inverter. - If it does not exceed Vstart, check for the presence of sufficient irradiation and the correct composition of the system. - If it exceeds Vstart, contact customer assistance
- W002 - Input UV -  Yellow LED	Insufficient irradiation (Low input voltage on switching off): Incorrect configuration of the photovoltaic generator or an "on the limit" configuration for the inverter's minimum input voltage.	<ul style="list-style-type: none"> • Check the input voltage on the inverter. - If it does not exceed Vstart, check for the presence of sufficient irradiation and the correct composition of the system. - If it exceeds Vstart, contact customer assistance

- Error code - Error message - LED status	Name of Alarm and Cause	Solution
- W003 - Grid Fail - ● Yellow LED	Parameters of grid voltage outside range: This error signal occurs when during the inverter's normal operation the grid parameters exceed the limits set by the operator: - Grid voltage absent (after the signal the inverter goes to "Missing Grid") - Unstable grid voltage (values too low or too high) - Unstable grid frequency	<ul style="list-style-type: none"> • Check the grid voltage on the inverter. - Should it be absent, check for absence of grid voltage on the supply point. - If, on the other hand, the voltage tends to rise (when the inverter is connected) there is high line or grid impedance. • Check the grid voltage also on the supply. - If it is high, it means that there is high grid impedance. In this case, ask the operator to adjust the grid voltage. If the operator authorises a change to the inverter's parameters, agree the new limits with customer assistance - If the voltage at the point of supply is much lower than that measured on the inverter, it is necessary to adjust the line (inverter-contactor). - If the voltage and the grid frequency come back within the limits (also when the inverter is connected to the grid), contact customer assistance
- W004 - Grid OV - ● Yellow LED	Grid overvoltage: This error signal occurs when during the inverter's normal operation the grid voltage exceeds the maximum limit set by the operator.	<ul style="list-style-type: none"> • Check the grid voltage on the inverter. If the voltage tends to rise (when the inverter is connected), there is a problem of high line or grid impedance. • Check the grid voltage also on the supply. - If it is high, it means that there is high grid impedance. In this case, ask the operator to adjust the grid voltage. If the operator authorises a change to the inverter's parameters, agree the new limits with customer assistance - If the voltage at the point of supply is much lower than that measured on the inverter, it is necessary to adjust the line (inverter-contactor). - If the voltage and the grid frequency come back within the limits (also when the inverter is connected to the grid), contact customer assistance
- W005 - Grid UV - ● Yellow LED	Grid undervoltage: This error signal occurs when during the inverter's normal operation the grid voltage exceeds the minimum limit set by the operator.	<ul style="list-style-type: none"> • Check the grid voltage on the inverter. • Check the grid voltage also on the supply. - If it is high, it means that there is high grid impedance. In this case, ask the operator to adjust the grid voltage. If the operator authorises a change to the inverter's parameters, agree the new limits with customer assistance - If the voltage at the point of supply is much lower than that measured on the inverter, it is necessary to adjust the line (inverter-contactor). - If the voltage and the grid frequency come back within the limits (also when the inverter is connected to the grid), contact customer assistance
- W006 - Grid OF - ● Yellow LED	Grid over-frequency: This error signal occurs when during the inverter's normal operation the grid frequency exceeds the maximum limit set by the operator.	<ul style="list-style-type: none"> • Check the grid frequency in the inverter. • Check the grid frequency also on the supply: - If the voltage and the grid frequency come back within the limits (also when the inverter is connected to the grid), contact customer assistance
- W007 - Grid UF - ● Yellow LED	Grid under-frequency: This error signal occurs when during the inverter's normal operation the grid frequency exceeds the minimum limit set by the operator.	<ul style="list-style-type: none"> • Check the grid frequency in the inverter. • Check the grid frequency also on the supply: - If the voltage and the grid frequency come back within the limits (also when the inverter is connected to the grid), contact customer assistance
- W011 - Bulk UV - ● Yellow LED	Low "Bulk" voltage (DC-DC circuit): The alarm (which is a warning and not an error) is generated when the voltage at the heads of the bulk capacitors does not reach the threshold for the operation of the inverter (internal unchangeable threshold).	<ul style="list-style-type: none"> • Raise the value of the activation voltage (Vstart) so as to have sufficient power from the PV generator at the time of the inverter's grid connection. • Check the input voltage on the inverter. - If it does not exceed Vstart, check for the presence of sufficient irradiation and the correct composition of the system. - If it exceeds Vstart, contact customer assistance.
- W012 - Batt. Low - ⊗ Flashing yellow LED	Battery Low: The inverter has detected a backup battery voltage that is too low.	<ul style="list-style-type: none"> • Check that the date/time are set correctly and, if they are not, set them. Subsequently arrange to completely switch off the inverter (on both AC and DC) and wait a few minutes. Finally, restart the inverter and check whether the date/time are now correctly set or whether they have reset to 01/01/2000. In this case replace the battery with the inverter completely switched off (isolate AC and DC side) being careful to maintain the polarity.











- Error code - Error message - LED status	Name of Alarm and Cause	Solution
- W013 - Clock Fail -  Flashing yellow LED	Clock Fail: The alarm occurs when there is a difference of more than 1 minute in the time shown on the Web User Interface compared to the internal time of the micro-processors and indicates a malfunction of the clock circuit.	<ul style="list-style-type: none"> • Error inside the inverter and cannot be checked externally. - If the alarm repeats persistently, contact customer assistance.
- W015 - Island Detect. -  Yellow LED	Disconnection due to Anti-Islanding: The inverter has been improperly connected to an island grid.	<ul style="list-style-type: none"> • Check that the grid to which the inverter is connected is not an island grid. - If the grid to which the inverter is connected is an island grid, switch the inverter off and then on again: if the problem persists, contact customer assistance.
- W018 * - DC SPD tripped -  Flashing yellow LED * (only for models with monitored SPD)	Intervention of overvoltage surge arresters on DC side: Overvoltage surge arresters situated on the DC side are damaged.	<ul style="list-style-type: none"> • Observe the inspection window on each surge arrester (DC side). If it is red, the surge arrester is damaged and the cartridge must be replaced. - If the alarm status persists, even if all the surge arresters have a green inspection window, contact customer assistance.
- W019 * - AC SPD tripped -  Flashing yellow LED * (only for models with monitored SPD)	Intervention of overvoltage surge arresters on AC side: Overvoltage surge arresters situated on the AC side are damaged.	<ul style="list-style-type: none"> • Observe the inspection window on each surge arrester (AC side). If it is red, the surge arrester is damaged and the cartridge must be replaced. - If the alarm status persists, even if all the surge arresters have a green inspection window, contact customer assistance.
W021 - P-reductionStart -  No LED	Activation of reduction in power: Indicates that one of the power limitations has been triggered.	<ul style="list-style-type: none"> • Check which power limitation code is active and, on the basis of that, carry out the necessary checks that might relate to various factors including: <ul style="list-style-type: none"> - settings by the user - high grid frequency - high grid voltage - anti-islanding - low grid voltage - high internal temperature - high input voltage
- W022 - Q-modeChange -  No LED	Variation in means of managing reactive power: Variation in the means of managing reactive power; this change can be made through the Web User Interface.	The variation in the means of managing reactive power is done directly by the customer/installer and is not an error. The information is only saved on the historic record of the events memorised by the inverter.
- W023 * - Date/time mod. -  No LED	Variation in the inverter's date and time: Variation of the inverter's date and time; this change can be made through the Web User Interface.	<ul style="list-style-type: none"> • The variation in the inverter's date and time is done directly by the customer/installer and is not an error. The information is only saved on the historic record of the events memorised by the inverter.
- W024 - Energy data rst -  No LED	Zeroing of the statistical energy data memorised in the EEPROM: Reset of the energy data saved in the inverter; this operation can be handled through the Web User Interface.	The zeroing of the partial energy values memorised by the inverter is done directly by the customer/installer and is not an error. The information is only saved on the historic record of the events memorised by the inverter <ul style="list-style-type: none"> • The warning may also occur when the Memory Card on which the production statistics are saved is replaced
W025 - P-reductionEnd -  No LED	Deactivation of reduction in power: Indicates that the inverter has come out of one of the power limitation states.	This type of warning does not need any check
- W046 - Grid conn. fault -  Yellow LED	Connection to the grid unsuccessful The alarm is logged when a Missing grid or Input UV error occurs or due to the manual disconnection of the inverter during the grid connection sequence.	<ul style="list-style-type: none"> • Once the error occurs, the inverter tries to return to normal operation. If the problem persists after a number of attempts to connect the inverter, switch the inverter off and then on again. - If the problem persists (once the inverter has been switched off and back on again), contact customer assistance.
- W047 - Update Incomplete -  Yellow LED	FW update method unsuccessful The alarm occurs when a firmware update has not been completed.	<ul style="list-style-type: none"> • Complete any pending firmware updates. - If the problem persists once the firmware updates have been completed, switch the inverter off and on again. - If the problem persists (once the inverter has been switched off and back on again), contact customer assistance.
- W048 - Periodic GridOff -  Yellow LED	Automatic disconnection from the grid due to time limit: If the inverter exceeds the set grid connection time limit set by the grid standard, it will automatically have to carry out a disconnection and reconnection to the grid to carry out the Riso test.	<ul style="list-style-type: none"> • The presence of this alarm is not an error as the automatic disconnection is prescribed by safety regulations. - If the inverter disconnects in a shorter time than expected, contact customer assistance.

- Error code - Error message - LED status	Name of Alarm and Cause	Solution
- W049 * - Global-Settings Event -  No LED	Variation of the grid standard Variation of the inverter's grid standard; this change can be made through the Web User Interface.	• The variation in the inverter's grid standard is done directly by the customer/installer and is not an error. The information is only saved on the historic record of the events memorised by the inverter
- W058 - System Frozen -  Yellow LED	Converter in locked state: The converter lock state is connected to an installation phase in which the start-up and grid connection conditions are not yet present.	• Complete the commissioning phase of the inverter. - If the problem persists (once the commissioning phase has been completed and the inverter has been switched off and back on again), contact customer assistance.
- E001 - Input OC -  Yellow LED	Input over-current (photovoltaic generator): The alarm occurs when the inverter's input current exceeds the inverter's threshold for maximum input current.	• Check whether the composition of the PV generator enables input current which exceeds the maximum threshold allowed by the inverter and that the configuration of the inputs (independent or in parallel) is carried out correctly. - If both checks are positive, contact customer assistance.
- E002 - Input OV -  Yellow LED	Input overvoltage (photovoltaic generator): The alarm is generated when the input voltage (from the PV generator) exceeds the inverter's threshold of maximum input voltage. The alarm is triggered before reaching the absolute threshold beyond which the inverter will be damaged. When the inverter's input voltage exceeds the Over Voltage threshold, the inverter will not start up due to the generation of the alarm.	• It is necessary to measure the input voltage inside the inverter with a voltmeter. - If it is higher than the maximum voltage of the operating range, the alarm is genuine and it is necessary to check the configuration of the PV generator. If the voltage has also exceeded the maximum input threshold the inverter could be damaged. - If it is lower than the maximum voltage of the operating range, the alarm is caused by an internal malfunction and it is necessary to contact customer assistance.
- E003 - No pars (DSP) -  Yellow LED	DSP initialisation error: The main microcontroller is unable to correctly initialize the two DSPs (booster stage and inverter stage). The error is caused by communication problems on the inverter's internal bus.	• Error inside the inverter and cannot be checked externally. - If the problem persists (once the inverter has been switched off and back on again), contact customer assistance.
- E004 - Bulk OV -  Yellow LED	"Bulk" over-voltage (DC-DC circuit): Error inside the inverter. The alarm is raised when the voltage at the heads of the bulk capacitors exceeds the Over Voltage threshold (internal unchangeable threshold).	• The alarm may be triggered by causes external to the inverter: - An excessive input voltage can be recorded as a condition for bulk over voltage. In this case it is advisable to check the inverter's input voltage and should this value be close to the input OV threshold, review the configuration of the photovoltaic generator. - Excessive grid voltage could cause the bulk voltage to rise in uncontrolled fashion with a consequent protection intervention and hence generation of the alarm. In these cases the alarm is transitory and the inverter automatically restarts - The alarm may be triggered by causes inside the inverter and in this case it is necessary to contact customer assistance.
- E005 - Internal error -  Yellow LED	Communication error inside the inverter: The alarm occurs when there are communication problems between the control devices inside the inverter.	• Error inside the inverter and cannot be checked externally. - If the problem persists (once the inverter has been switched off and back on again), contact customer assistance.
- E006 - Output OC -  Yellow LED	Output overcurrent: The alarm occurs when the inverter's output current exceeds the inverter's threshold for maximum output current.	• Error inside the inverter and cannot be checked externally. - If the problem persists (once the inverter has been switched off and back on again), contact customer assistance.
- E007 - IGBT Sat -  Yellow LED	Saturation recorded on the IGBT components: The alarm appears when one of the active devices of the inverter is in saturation state.	Once the error appears, the inverter attempts to resume normal operation. - Should the error occur sporadically, it may be caused by a brusque transition of the grid voltage or of the input voltage, but is not due to a malfunction by the inverter. - If the error is connected to an internal fault, it will continue to appear and so it is necessary to contact customer assistance.
- E009 - Internal error -  Yellow LED	Error inside the inverter: Error inside the inverter	• Error inside the inverter and cannot be checked externally. - If the problem persists (once the inverter has been switched off and back on again), contact customer assistance.

- Error code - Error message - LED status	Name of Alarm and Cause	Solution
- E010 - Bulk UV -  Yellow LED	Low "Bulk" voltage (DC-DC circuit): The alarm can be caused by causes external to the inverter: a reduced input voltage on the inverter (just above the activation voltage) but which is not accompanied by a sufficient availability of power from the photovoltaic generator (typical condition of the stages with limited irradiation)	<ul style="list-style-type: none"> - If the error signal occurs sporadically, it may be due to causes external to the inverter (limited irradiation and so limited power availability from the PV generator). - If the problem occurs systematically even in conditions of high irradiation and with input voltage which is significantly higher than the activation voltage, contact customer assistance.
- E011 - Ramp Fault -  Yellow LED	Long wait for "Booster" regime to start: Error internal to inverter relating to start up time for DC-DC circuit regime (Booster)	<ul style="list-style-type: none"> • Error inside the inverter and cannot be checked externally. - If the problem persists (once the inverter has been switched off and back on again), contact customer assistance.
- E012 - Internal error -  Yellow LED	Error in the "Booster" circuit (DC-DC side) recorded by the "Inverter" circuit (DC-AC side): Error inside the inverter regarding the operation of the DC-DC circuit part (Booster).	<ul style="list-style-type: none"> • Error inside the inverter and cannot be checked externally. - If the problem persists (once the inverter has been switched off and back on again), contact customer assistance.
- E014 - Over temperature -  Yellow LED	Excessive temperature inside the inverter: External temperature over 60°C. This parameter also depends on the power which the inverter must supply since the measurement of temperatures is done internally and is influenced by the heat dissipated by the components of the inverter itself	<ul style="list-style-type: none"> • Check that the inverter is not exposed to direct sunlight. Wait for the temperatures to which the inverter is exposed to return to the operating range and for the inverter to cool down. - If the problem persists (once the ambient temperature has returned to within the range), contact customer assistance. You must remember to wait for the time necessary to allow the inverter to cool down.
- E015 - Cap. Fault -  Yellow LED	Breakdown recorded on the "Bulk" capacitor: Error inside the inverter regarding a problem in the bulk capacitors.	<ul style="list-style-type: none"> • Error inside the inverter and cannot be checked externally. - If the problem persists (once the inverter has been switched off and back on again), contact customer assistance.
- E016 - Internal error -  Yellow LED	Error in the "Inverter" circuit (DC-AC side) recorded by the "Booster" circuit (DC-DC side): The alarm is generated when a problem is detected in the inverter circuit part (DC/AC).	<ul style="list-style-type: none"> • Error inside the inverter and cannot be checked externally. - If the problem persists (once the inverter has been switched off and back on again), contact customer assistance.
- E017 - Internal error -  Yellow LED	Long wait for "Inverter" regime to start up: Error internal to inverter relating to start-up time for the DC-AC circuit regime (Inverter) The alarm can be caused by causes external to the inverter: a reduced input voltage on the inverter (just above the activation voltage) but which is not accompanied by a sufficient availability of power from the photovoltaic generator (typical condition of the stages with limited irradiation)	<ul style="list-style-type: none"> - If the error signal occurs sporadically, it may be due to causes external to the inverter (limited irradiation and so limited power availability from the PV generator). - If the problem occurs systematically even in conditions of high irradiation and with input voltage which is significantly higher than the activation voltage, contact customer assistance.
- E018 - Leak fault -  Red LED	High leakage current measured on the DC side (photovoltaic generator): The alarm is generated when, during normal operation of the inverter, a leakage current to ground is detected in the DC section of the system. It is also possible that the inverter generates the alarm E018 message also due to AC leakage currents connected to the capacitive nature of the photovoltaic generator compared to ground.	<ul style="list-style-type: none"> • Measure the isolation resistance using a megohmmeter positioned in the photovoltaic array (positive terminal short-circuited at the negative pole) compared to ground. The measurement is strongly influenced by the environmental conditions, so must be made under the same conditions in which the error occurred. - If the value measured is lower than 1 megaohm, a check must be carried out by a technician/installer on the photovoltaic generator to identify and eliminate the problem. - If the value measured is higher than 1 megaohm and the error signal persists, contact customer assistance.
- E019 - Internal error -  Yellow LED	Failure of test on sensor to measure the leakage current (DC side): Before connecting to the grid the inverter runs a self-test regarding the sensor for the leakage current. The test is carried out by "forcing", in the sensor of the leakage current, a current with a known value: the microprocessor compares the value read with the known value. The error is generated if the comparison between the read value and the known value during the test does not fall within the allowed tolerance.	<ul style="list-style-type: none"> • Error inside the inverter and cannot be checked externally. By its nature, the alarm only occurs prior to connection to the grid - If the problem persists (once the inverter has been switched off and back on again), contact customer assistance.

- Error code - Error message - LED status	Name of Alarm and Cause	Solution
- E020 - Internal error - Yellow LED	Failure of the test on the relay of the “Booster” (DC-DC circuit): Before connecting to the grid, the inverter carries out some internal tests. One of these tests concerns the correct operation of the booster relay. The test is carried out by “forcing” the switching of the relay and checking its operation. The error is generated if a problem is found in actio-ning the relay.	• Error inside the inverter and cannot be checked externally. By its nature, the alarm only occurs prior to connection to the grid - If the problem persists (once the inverter has been switched off and back on again), contact customer assistance.
- E021 - Internal error - Yellow LED	Failure of the test on the inverter's relay (DC-AC circuit): Before connecting to the grid, the inverter carries out some internal tests. One of these tests concerns the correct operation of the inverter relay. The test is carried out by “forcing” the switching of the relay and checking its operation. The error is generated if a problem is found in actio-ning the relay.	• Error inside the inverter and cannot be checked externally. By its nature, the alarm only occurs prior to connection to the grid - If the problem persists (once the inverter has been switched off and back on again), contact customer assistance.
- E022 - Internal error - Yellow LED	Timeout of the tests undertaken on the relays inside the inverter: Execution time for the self-test carried out on the relay of the DC_AC (inverter) circuit too high. It may indica-te a problem connected to the aforementioned relays	• Error inside the inverter and cannot be checked externally. - If the problem persists (once the inverter has been switched off and back on again), contact customer assistance.
- E023 - DC injection - Yellow LED	Feeding of direct current to grid outside of range: The error is generated if the direct component of the current supplied to the grid exceeds the threshold of 0.5% of the rated operating current. In any case, the inverter does not stop because of the E023 error, but tries to connect to the grid again. The sporadic repetition of the error is a sign of serious grid distortions or sharp irradiation changes, while systematic repetition of the error signal will indicate a breakdown on the inverter	Once the error appears, the inverter attempts to resume normal operation. - Should the error occur sporadically, it may be caused by a brusque transition of the grid voltage or of the input voltage, but is not due to a malfunction by the inverter. - If the error is connected to an internal fault, it will continue to appear and so it is necessary to contact customer assistance.
- E024 - Internal error - Yellow LED	Error inside the inverter: Error inside the inverter	• Error inside the inverter and cannot be checked externally. - If the problem persists (once the inverter has been switched off and back on again), contact customer assistance.
- E025 - Riso Low - Red LED	Low value of isolation resistance: Before connecting to the grid the inverter measures the isolation resistance of the PV generator compared to ground. Should the measurement of the isolation resistan-ce be below 1Mohm, the inverter does not connect to the grid and shows the “Riso Low” error. The causes may be: - Damaged PV panel(s). - Junction box(es) of the panels not correctly sealed, so as to permit infiltration by water and/or humidity; - Problems in connections between panels (not perfectly fit); - Poor quality of cable joints; - Presence in the DC section of unsuitable or dama-ged overvoltage surge arresters outside the inverter (reduced ignition voltage compared to the characte-ristics of the strings of the PV generator); - Presence of humidity inside any junction box	• Measure the isolation resistance using a megohmmeter positioned in the photovoltaic array (positive terminal short-circuited at the negative pole) compared to ground. The measurement is strongly influenced by the environmental conditions, so must be made under the same conditions in which the error occurred. - If the value measured is lower than 1 megaohm, a check must be carried out by a technician/installer on the photovol-taic generator to identify and eliminate the problem. - If the value measured is higher than 1 megaohm and the error signal persists, contact customer assistance.
- E026 - Internal error - Yellow LED	Internal reference voltage outside of range: Wrong measurement of reference voltage inside inverter	• Error inside the inverter and cannot be checked externally. - If the problem persists (once the inverter has been switched off and back on again), contact customer assistance.
- E027 - Internal error - Yellow LED	Grid voltage outside of range: Error in the internal measurement of grid voltage (set by law) to have a redundant measurement (2 measurements on the same parameter made by two different circuits)	• Error inside the inverter and cannot be checked externally. - If the problem persists (once the inverter has been switched off and back on again), contact customer assistance.

- Error code - Error message - LED status	Name of Alarm and Cause	Solution
- E028 - Internal error - Yellow LED	Grid frequency outside of range: Error in the internal measurement of the grid frequency (imposed by regulations) to have a measurement redundancy (2 measurements on the same parameter carried out by two different circuits).	• Error inside the inverter and cannot be checked externally. - If the problem persists (once the inverter has been switched off and back on again), contact customer assistance.
- E029 - Mid Bulk OV - Yellow LED	Internal overvoltage on the measurement of the “Mid bulk”: Error inside the inverter (only triphase models)	• Error inside the inverter and cannot be checked externally. - If the problem persists (once the inverter has been switched off and back on again), contact customer assistance.
- E030 - Internal error - Yellow LED	High leakage current (DC side): - Error on the internal measurement (performed when the inverter is connected to the grid) of the DC side (PV generator) leakage current with respect to ground (required by regulations) to have a measurement redundancy (2 measurements of the same parameter carried out by two independent circuits)	• Error inside the inverter and cannot be checked externally. - If the problem persists (once the inverter has been switched off and back on again), contact customer assistance.
- E031 - Internal error - Yellow LED	Output relay damaged: Measurement of internal voltage on heads of the output relay outside of range. There is too great a difference in voltage between the input and output of the grid connection relay.	• Error inside the inverter and cannot be checked externally. - If the problem persists (once the inverter has been switched off and back on again), contact customer assistance.
- E032 - Internal error - Yellow LED	Imbalanced output currents: Measurement of the unbalance in the output voltage (made across the three phases) outside of range (only in three-phase models)	• Error inside the inverter and cannot be checked externally. - If the problem persists (once the inverter has been switched off and back on again), contact customer assistance.
- E033 - Undertemperature - Yellow LED	Low ambient temperature: Temperature outside the inverter below -25°C	• Wait for the temperatures to which the inverter is exposed to return to the operating range. - If the problem persists, contact customer assistance. You must remember to wait for the time necessary to allow the inverter to warm up.
- E034 - IGBT not ready - Yellow LED	“IGBT” circuitry not ready: Error inside the inverter	• Error inside the inverter and cannot be checked externally. - If the problem persists (once the inverter has been switched off and back on again), contact customer assistance.
- E035 - Remote Off - Yellow LED	Inverter awaiting “remote ON” command: The inverter has been switched off remotely (remote OFF) and remains in waiting state for the signal that will switch it on again (remote ON).	• Switch the inverter back on remotely. If the unit does not switch on, disable the remote on/off function and switch the equipment off completely and then switch it on again. - If the problem persists (once the Remote ON/OFF function has been reactivated), contact customer assistance.
- E036 - Internal error - Yellow LED	Average of the measurements of grid voltage outside of range: The average value of the grid voltage (sampled every 10 minutes) does not fall within the permitted ranges. The grid voltage in the point connected to the inverter is too high. This may be caused by a grid impedance that is too high. In the final stage of the timeout, the inverter limits the power to check whether the grid voltage has stabilised into regular parameters. If this does not happen, the inverter disconnects from the grid	• Check the grid voltage in the connection point to the inverter. - If the grid voltage differs from the range due to the conditions of the distribution grid, ask the operator to adjust the grid voltage. If the operator authorises a change to the inverter's parameters, agree the new limits with customer assistance.
- E037 - Riso Low - Red LED	Low value of the isolation resistance (only with the “Amorphous” mode activated): This error can appear only if the “Amorphous” mode is enabled. This function is enabled only in inverters equipped with grounding kit and is used to monitor the voltage at the ends of the grounding resistor. The error appears when the voltage at the ends of the resistor connected between ground and pole of the photovoltaic generator exceeds 30V for more than 30 minutes or 120V for more than one second.	• Check for the presence and correct contact between the two terminals of the grounding resistance installed inside the inverter • Measure the isolation resistance using a megohmmeter positioned in the photovoltaic array (positive terminal short-circuited at the negative pole) compared to ground. The measurement is strongly influenced by the environmental conditions, so must be made under the same conditions in which the error occurred. - If the value measured is lower than 1 megaohm, a check must be carried out by a technician/installer on the photovoltaic generator to identify and eliminate the problem. - If the value measured is higher than 1 megaohm and the error signal persists, contact customer assistance.

- Error code - Error message - LED status	Name of Alarm and Cause	Solution
E046 - Str. test failed -  No LED	Error during the automatic check of the string voltages (only in models with the “fuse-control” board): In some inverter models it is possible to carry out the check test of the polarity of the strings connected to the input. This error signal occurs when, during the test stage, an inverted string is recorded	<ul style="list-style-type: none"> • Section the inverter and check the polarity of the string(s) which the inverter has recorded as inverted. - Once all the strings have been correctly connected, activate the system once again; the inverter will once again check the correct polarity of the string inputs at the end of which it will carry out the checks for the grid connection. - If the problem persists (once the inverter has been switched off and back on again), contact customer assistance.
E049 - Internal error - 	Error in the “AC feed-forward” circuit: Error inside the inverter	<ul style="list-style-type: none"> • Error inside the inverter and cannot be checked externally. - If the problem persists (once the inverter has been switched off and back on again), contact customer assistance.
E051 - Safety mem. Fault - 	Error inside the inverter.	<ul style="list-style-type: none"> • Error inside the inverter and cannot be checked externally. - If the problem persists (once the inverter has been switched off and back on again), contact customer assistance.
E057 - Vbulk reading - 	Input voltage (Vin) higher than booster voltage (Vbulk): The error occurs if the input voltage exceeds the Bulk voltage (voltage on the DC-DC circuit inside the inverter)	<ul style="list-style-type: none"> • It is necessary to measure the input voltage inside the inverter with a voltmeter. - If it is higher than the maximum voltage of the operating range, the alarm is genuine and it is necessary to check the configuration of the PV generator. If the voltage has also exceeded the maximum input threshold the inverter could be damaged. - If it is lower than the maximum voltage of the operating range, the alarm is caused by an internal malfunction and it is necessary to contact customer assistance.
E058 - Internal error - 	Error in the check of Pin vs Pout: The error occurs if the difference between the measured value of input power and that of output power is greater than the limit imposed internally to the inverter.	<ul style="list-style-type: none"> • Error inside the inverter and cannot be checked externally. - If the problem persists (once the inverter has been switched off and back on again), contact customer assistance.
E074 - Internal error - 	Communication error inside the inverter: The alarm occurs when there are communication problems between the control devices inside the inverter.	<ul style="list-style-type: none"> • Error inside the inverter and cannot be checked externally. - If the problem persists (once the inverter has been switched off and back on again), contact customer assistance.
E077 - Internal Error - 	Error in the system configuration: Error inside the inverter	<ul style="list-style-type: none"> • Error inside the inverter and cannot be checked externally. - If the problem persists (once the inverter has been switched off and back on again), contact customer assistance.
E078 - Riso Test fail - 	Riso test error: Problem detected during the Riso test phase.	<ul style="list-style-type: none"> • Error inside the inverter and cannot be checked externally. - If the problem persists (once the inverter has been switched off and back on again), contact customer assistance.
E079 - Wrong Sequence - 	Incorrect Phases connection (Only triphase models) The phases have not been connected correctly to the AC output	<ul style="list-style-type: none"> • Invert two of the phases of the network wiring to the AC terminal block of the inverter.
E084 - BackFeed OC - 	Return current to photovoltaic field: The error occurs if the input voltage is particularly low (typically in the evening in conditions of low irradiation) and indicates a return current from the inverter to the photovoltaic panels).	<ul style="list-style-type: none"> • If the error occurs in the evening or in conditions of low irradiation, it must not be considered a problem but a protection intervention for the photovoltaic field. - If the error occurs with good irradiation conditions, switch the inverter off and back on again; if the error persists, contact customer assistance.

Power limitation messages

The equipment can signal possible output power limitations which may occur on the basis of:

- settings made by the user
- settings required by the grid standard of the country of installation
- protective devices inside the inverter

The limitation messages can only be verified on the Web User Interface on “Status Summary” section.

Registration on “Registration” website and calculation of security token (Admin Plus)

In order to obtain the security token needed to obtain the “Admin Plus” privileges in the web user interface, it is necessary to go through the following stages:

Stage 1 - Collection of information relating to the inverter.

Collect the following information relating to each inverter for which you wish to have the security token:

- **S/N** - Serial number of the inverter. This information can be found on the product label giving the identity details of the inverter.

The serial number consists of 6 digits (the last 6 in models with a label giving a 10-digit S/N).

- **WK** - Production week. This information can be found on the product label giving the identity details of the inverter.

The production week consists of 4 figures, indicating the week (first 2 digits) and the year of production (last 2 digits).

Stage 2 - Registration on <https://registration.solar.fimer.com>

- Go online and access <https://registration.solar.fimer.com>

- Set the desired language and click on the specific icon to start registration

- Insert the personal data requested and end the registration stage

- An email will be sent to the email address used with a link to complete the registration process.

- Once the registration process is over, a further email will be sent with the password to access the website.



The security token obtained enables access also to the advanced “Installer” mode present on the configuration software for inverters. The configuration software can be downloaded in a specific section of the website <https://registration.solar.fimer.com>

Stage 3 - Request for the security token

- Go online and access <https://registration.solar.fimer.com>
- Insert the Username (corresponding to the email used during registration) and the Password obtained at the end of Stage 2

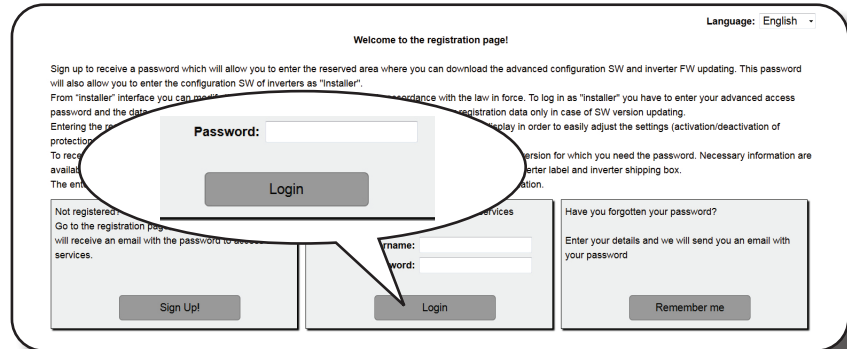

- Access the section dedicated to requesting the security token

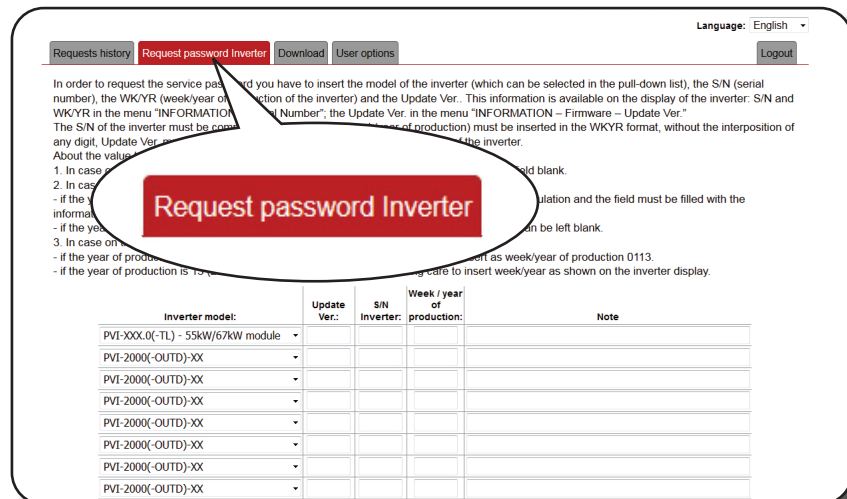

- Choose the inverter model from the drop-down list and insert Serial Number and Week of Production of the inverter which were obtained previously (Stage 1)

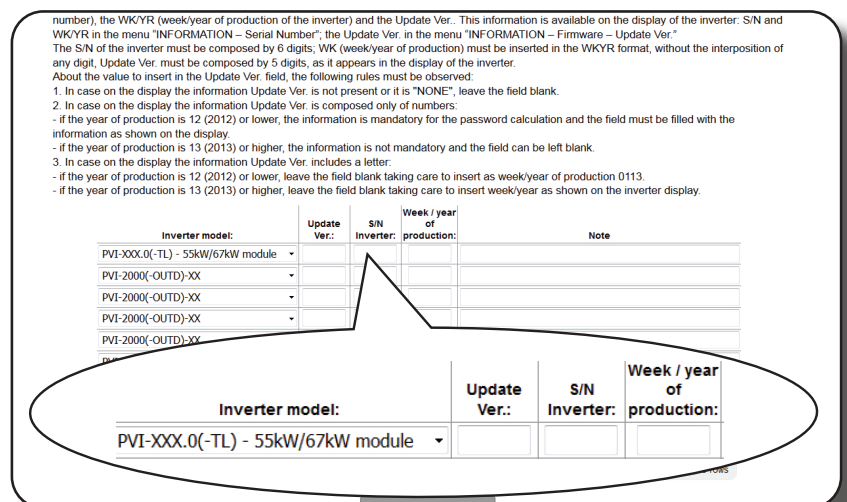

- Click on icon to request the security token.

Language: English Logout

Requests history **Request password Inverter** Download User options

In order to request the service password you have to insert the model of the inverter (which can be selected in the pull-down list), the S/N (serial number), the WKYR (week/year of production of the inverter) and the Update Ver. This information is available on the display of the inverter: S/N and WKYR in the menu "INFORMATION – Serial Number", the Update Ver. in the menu "INFORMATION – Firmware – Update Ver." The S/N of the inverter must be composed by 6 digits, WK (week/year of production) must be inserted in the WKYR format, without the interposition of any digit, Update Ver. must be composed by 5 digits, as it appears in the display of the inverter.

About the value to insert in the Update Ver. field, the following rules must be observed:

1. In case on the display the information Update Ver. is not present or it is "NONE", leave the field blank.
2. In case on the display the information Update Ver. is composed only of numbers.
 - if the year of production is 12 (2012) or lower, the information is mandatory for the password calculation and the field must be filled with the information as shown on the display.
 - if the year of production is 13 (2013) or higher, the information is not mandatory and the field can be left blank.
3. In case on the display the information Update Ver. includes a letter.
 - if the year of production is 12 (2012) or lower, leave the field blank taking care to insert as week/year of production 0113.
 - if the year of production is 13 (2013) or higher, leave the field blank taking care to insert week/year as shown on the inverter display.

Inverter model:	Update Ver.:	S/N Inverter:	Week / year of production:	Note
PVI-XXX,0(-TL) - 55kW/67kW module		123456	1117	
PVI-2000(-OUTD)-XX				
PVI-2000(-OUTD)-XX				
PVI-2000(-OUTD)-XX				
PVI-2000(-OUTD)-XX				
PVI-2000(-OUTD)-XX				
PVI-2000(-OUTD)-XX				
PVI-2000(-OUTD)-XX				
PVI-2000(-OUTD)-XX				
PVI-2000(-OUTD)-XX				
PVI-2000(-OUTD)-XX				
PVI-2000(-OUTD)-XX				
PVI-2000(-OUTD)-XX				
PVI-2000(-OUTD)-XX				

Add other 10 rows

Do request

Should there be an error in inputting data, the fields containing the error will be highlighted in red. If, on the other hand, the data are correct, the passwords will be shown in a new window and at the same time sent to the email address used for registration.



The security token enables the "Admin Plus" privileges which allows the inverter's sensitive parameters to be changed. Proceed to changing the aforementioned parameters only when requested by the grid operator or by customer assistance.

Procedure for dismantling the equipment



The dismantling operations must be carried out with the equipment disconnected from any voltage sources. Refer to “*Inverter total de-energization and safe access*” chapter on this manual to know all the necessary step to safely operate on the inverter.



Never open the power module 01 or wiring box 02 in the case of rain, snow or a level of humidity >95%. Always carefully seal all unused openings.

Even though the device is equipped with an anti-condensation valve, air with extremely high levels of humidity can lead to the creation of condensation inside the inverter.

As the inverter is almost completely insulated from the outside, condensation can also form after maintenance interventions in certain weather conditions.



During dismantling always protect the inverter parts that are installed and exposed to the weather elements!



Staff authorised to carry out the dismantling operations must be specialised and experienced in this job. They must also have received suitable training on equipment of this type.

The inverter consists of an power module 01, a wiring box 02 and a mounting bracket 03 which may be dismantled separately.

To dismantling and disassemble the power module 01 follow these steps:

- Disconnect any external voltage sources and isolate the equipment referring to the “*Inverter total de-energization and safe access*” chapter.
- Disconnect all internal connectors between power module 01 and wiring box 02 referring to “*Mounting with a support bracket - Interface connectors connection*” chapter (Follow the indications for connection procedure but in the reverse order).
- Disjoint the power module 01 and wiring box 02 enclosures referring to “*Mounting with a support bracket - Final Fastening operations*” chapter (Follow the indications for the mounting procedure but in the reverse order).
- Slightly lift the power module 01 to allow the gasket protective covers insertion.

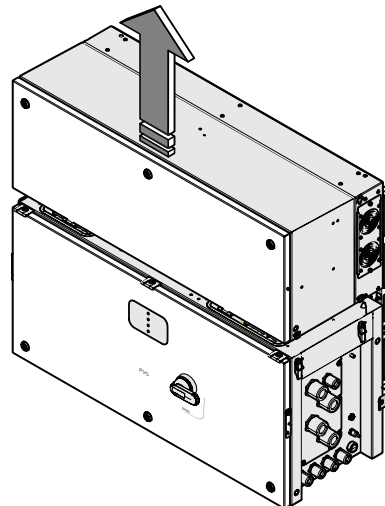

- Slide the gasket protective covers between power module 01 and wiring box 02 enclosures.

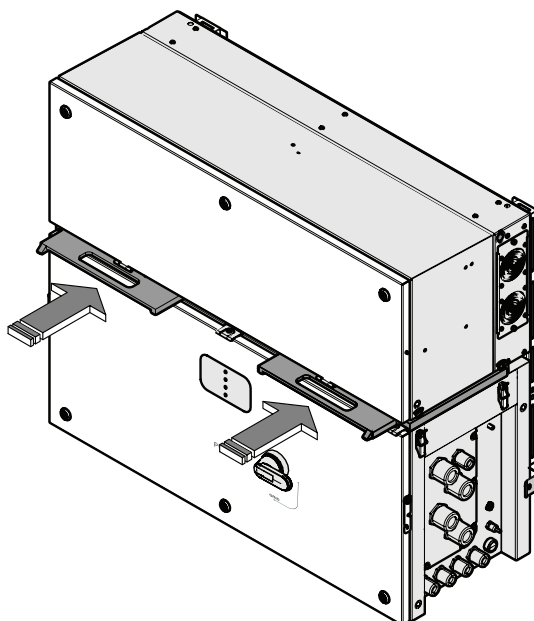

- Remove the power module 01 following the indications for the mounting procedure in the “Mounting with a support bracket - Assembly the Inverter to the bracket” chapter in the reverse order and the indication for lifting methods in “Type of lifting” chapter.



Never leave the power module 01 or the wiring box 02 disassembled on the field. In case is necessary to disassemble the power module 01 only, a IP65 protection covers for wiring box openings (long term installation) kit is available as accessory options.

To dismantling and disassemble the wiring box 02 follow these steps:

- Remove the power module 01 as previously described.
- Remove AC cables and protective earth cable.
- Remove any signal cables.
- Remove the wiring box 02 following the indications for the mounting procedure in the “Mounting with a support bracket - Assembly the Inverter to the bracket” chapter in the reverse order and the indication for lifting methods in “Type of lifting” chapter.

To dismantling and disassemble the mounting bracket 03 follow the indications for the mounting procedure in the “Mounting with a support bracket - Bracket assembly” chapter in the reverse order.

Replacing cooling section



Some inverter parts may be subject to voltages that could be hazardous for the operator. Before performing any work on the inverter, refer to “Inverter total de-energization and safe access” chapter on this manual to know all the necessary step to safely operate on the inverter.

Procedure for replacing one of the two cooling sections:

1. Perform the “inverter total de-energization and safe access” procedure before operate on the inverter.
2. Remove the 2 screws (STEP A).
3. Tilt the cooling section as shown in the picture (STEP B).
4. Pull out the cooling section (STEP C).
5. Disconnect the 2 fan connectors (STEP D).
6. Take the new cooling section and connect the 2 fan connectors. During this phase pay attention to connect the fan to the correspondent cable; on each fan cable coming from the power module and on each fan are applied labels that indicates the fans number (from FAN1 to FAN4).
7. Place the new cooling section in the reverse way of previous steps.
8. Screw the 2 fastening screws.

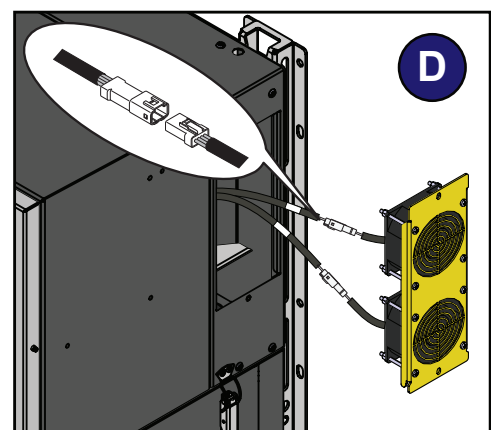
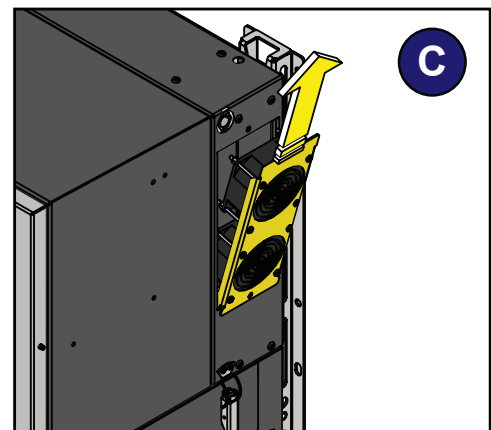
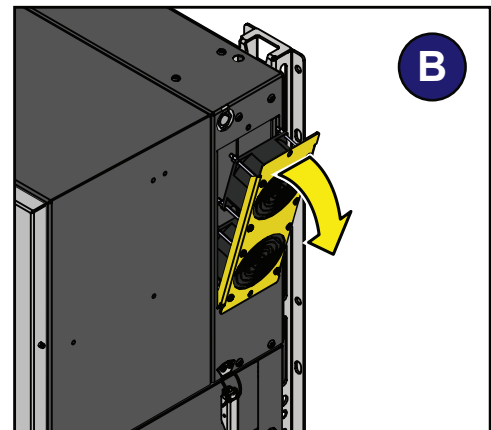
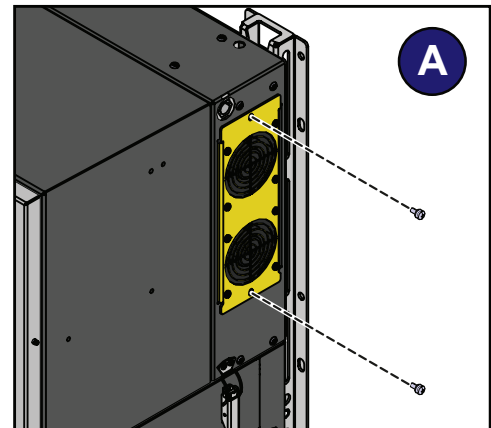
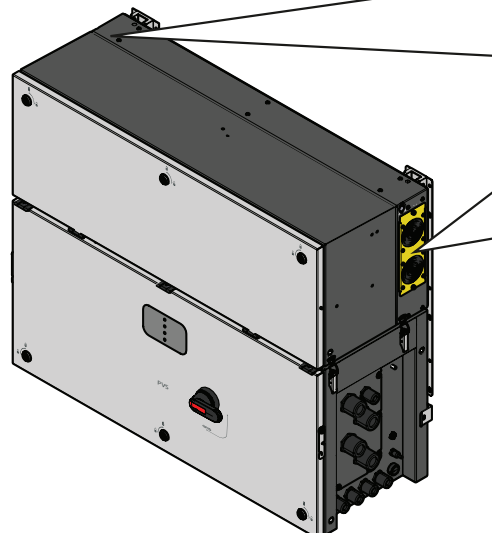

Replacing fan section (internal)



Some inverter parts may be subject to voltages that could be hazardous for the operator. Before performing any work on the inverter, refer to “Inverter total de-energization and safe access” chapter on this manual to know all the necessary step to safely operate on the inverter.

Procedure for replacing one of the two fan sections:

1. Perform the “Inverter total de-energization and safe access” procedure before operate on the inverter.
2. Open the front wiring box cover 07.
3. Remove the 2 screws (STEP A).
4. Pull out the fan section (STEP B).
5. Place the new fan section in the reverse way of previous steps

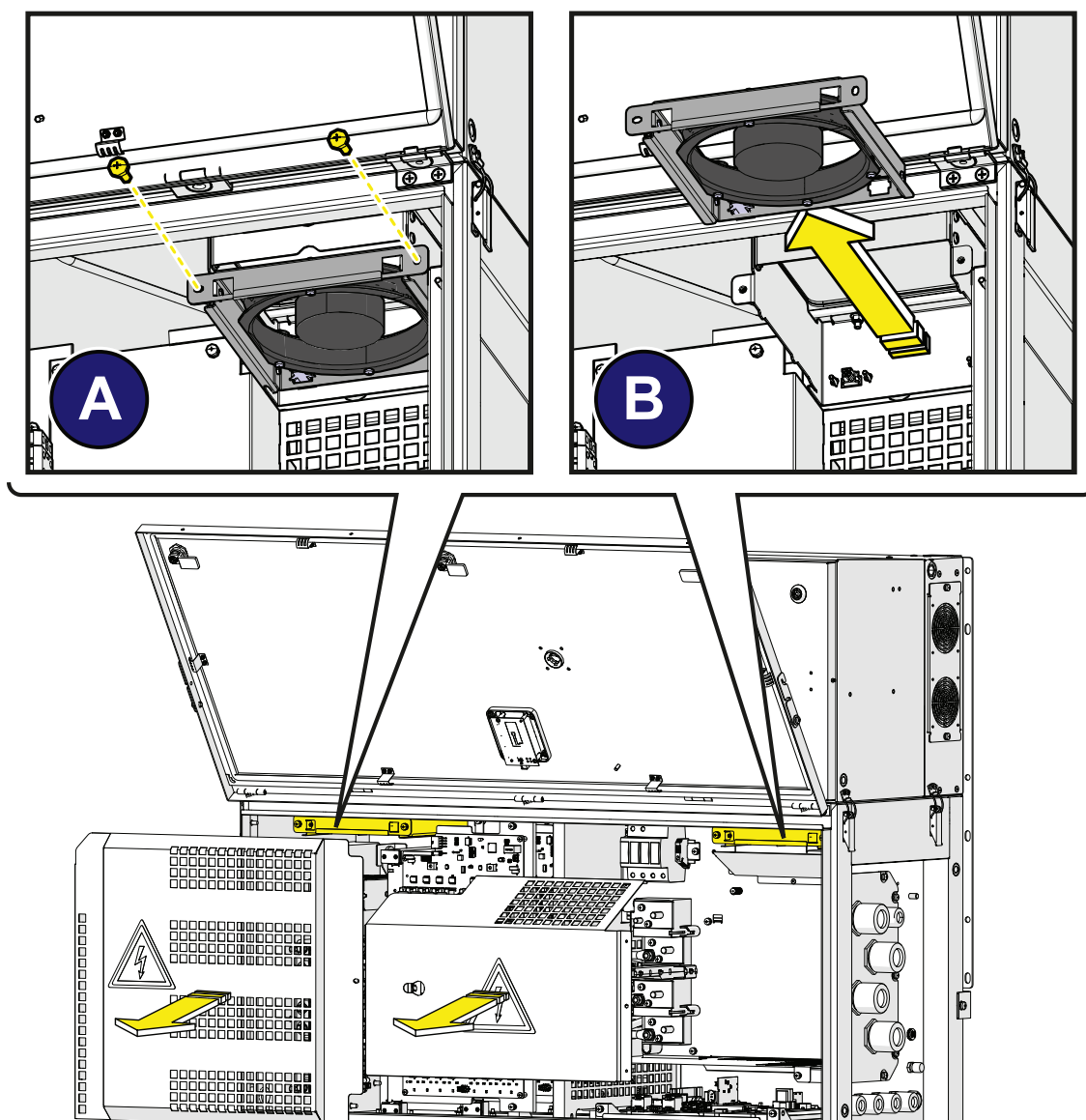

Replacing the DC surge arrester boards (-SX/SX2 models only)

Replacing the DC surge arrester boards may be necessary in the following circumstances:

1. "Alarm" LED flashing, "Power" LED steady ON.
2. Presence of "W018" Error in Inverter Log section of web user interface.
3. The inspection window of DC surge arrester cartridge is RED.

The DC overvoltage surge arrester board **53** is placed inside the wiring box **02** and is accessible after opening both fuse boards (positive and negative).

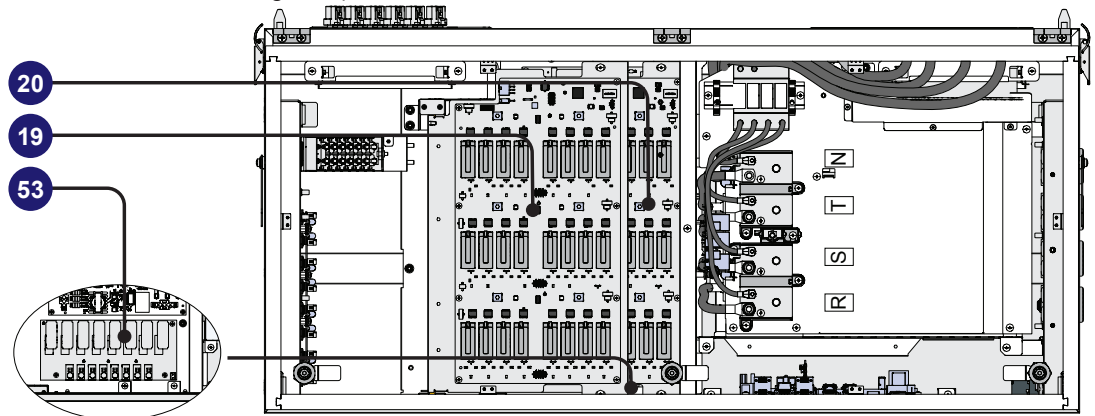

Procedure for replacing one of the DC surge arrester boards:



Some inverter parts may be subject to voltages that could be hazardous for the operator.

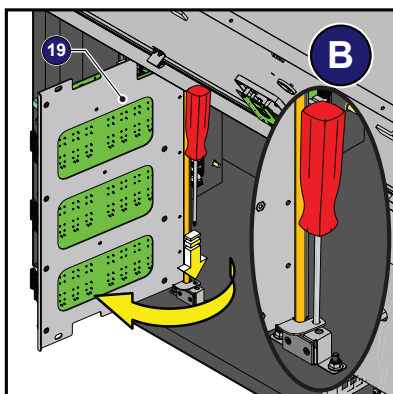
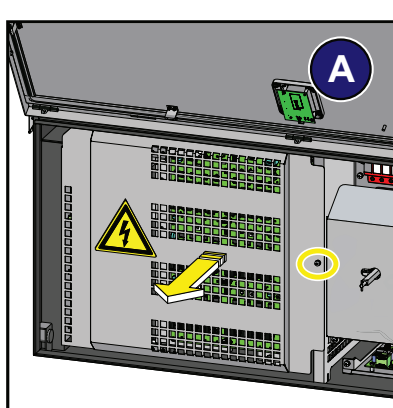

1. Before performing any work on the inverter, refer to "Inverter total de-energization and safe access" chapter on this manual to know all the necessary step to safely operate on the inverter.
2. Open the front wiring box cover **07**.
3. Remove the screw and the DC protective shield **60** (picture **A**)
4. Open the positive fuse board
 - Remove the two M5 screws from the positive string fuses plate **19**.
 - Tilt the positive string fuses plate **19**.
 - Use a screwdriver, to lock the positive string fuses plate (picture **B**)

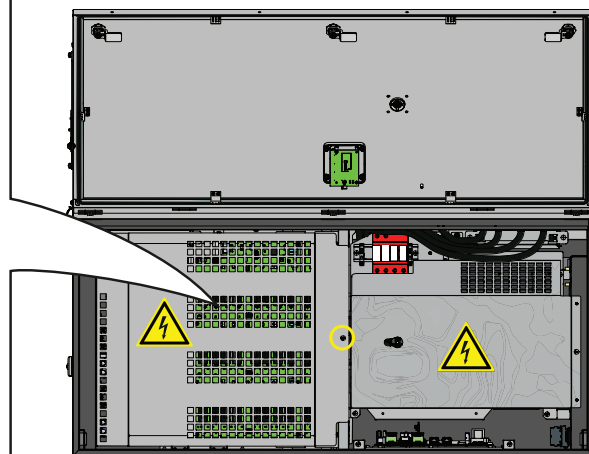

5. Open the negative fuse board
 - Remove the two M5 screws from the negative string fuses plate 20.
 - Tilt the negative string fuses plate 20.
 - Use a screwdriver, to lock the positive string fuses plate

6. Disconnect the cables from the spring clamps.

During this operation take note of the cables position in order to connect them in the same way in the new board.

 - A) Insert a flat screwdriver in the slot (see the picture); lightly press the screwdriver from the top to the bottom; insert the screwdriver until the clamp opens.
 - B) Insert the cable in the clamp.
 - C) Remove the screwdriver.

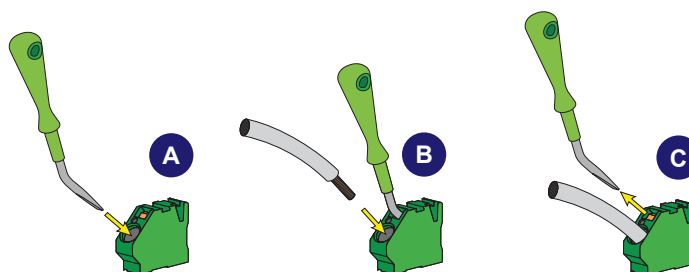

7. Disconnect the surge arresters monitoring connector

8. Remove the card through the three screws

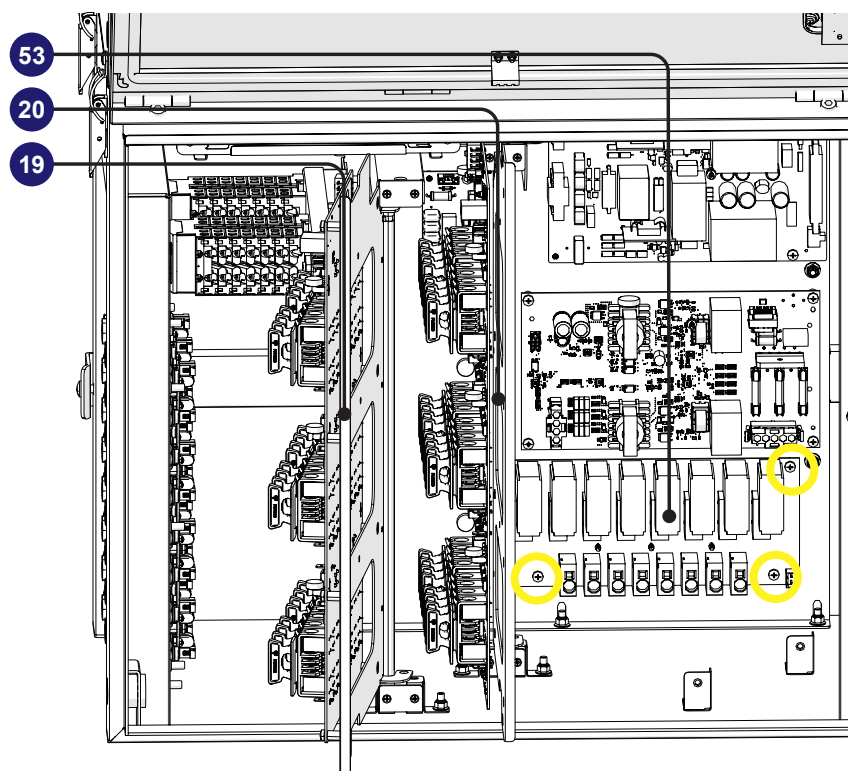

9. Replace the DC overvoltage surge arrester board **53**

10. Re-connect the cables on the connector of the board **53** paying attention to respect the previous position

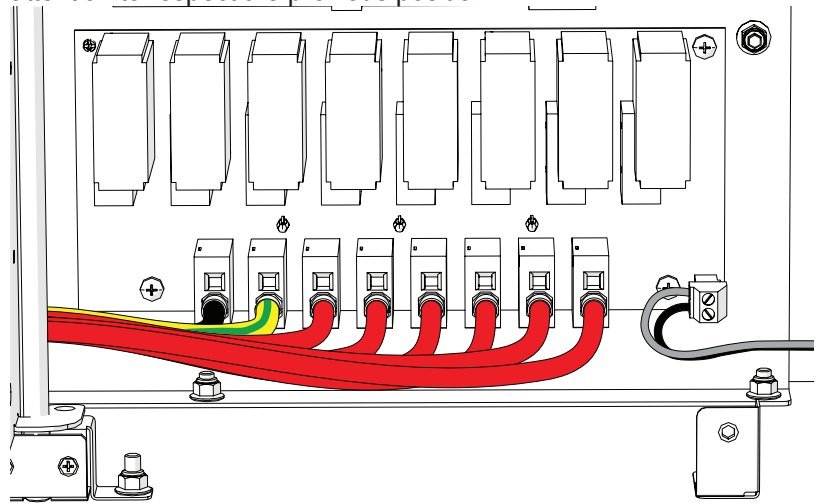

11. Close both string fuses boards

12. Re-install the DC protective shield **60**

13. Close the front cover of the wiring box

14. Re-commission the inverter.

Replacing the AC surge arrester cartridge (-SX/SX2 models only)

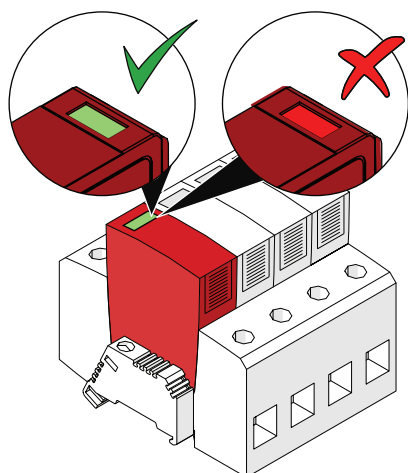

Replacing the AC surge arrester cartridges **22** may be necessary in the following circumstances:

1. “Alarm” LED flashing, “Power” LED steady ON.
2. Presence of “W019” Error in Inverter Log section of web user interface.
3. The inspection window of AC surge arrester cartridge is RED.

The AC surge arrester cartridges **22** are installed inside the wiring box **02**.

Procedure for replacing one of the AC surge arrester cartridges **22**:



Some inverter parts may be subject to voltages that could be hazardous for the operator.

1. Before performing any work on the inverter, refer to “Inverter total de-energization and safe access” chapter on this manual to know all the necessary step to safely operate on the inverter.
2. Open the front wiring box cover **07**.
3. Push the side snaps and pull out the cartridges.
4. Insert the new cartridge in the empty slot.

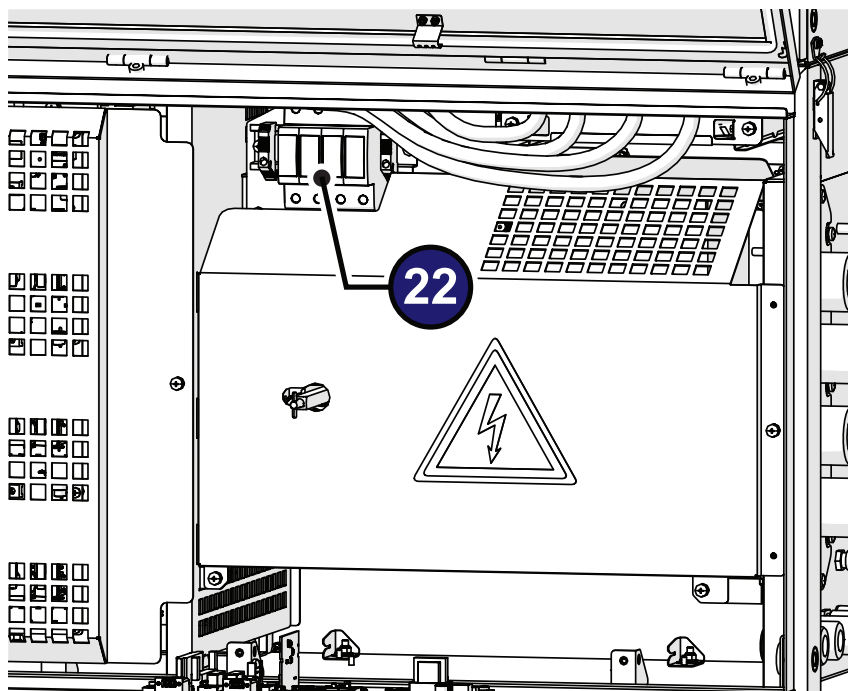

5. Close the wiring box front cover **07**.
6. Re-commission the inverter.

Replacement of the Memory board

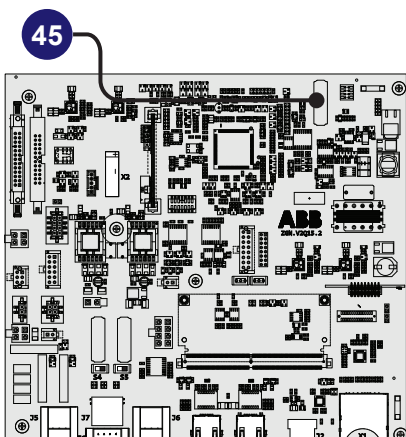

Replacing the MEMORY board is carried out on the wiring box **02** and may be necessary in case of Inverter log Statistic (e.g. power production) lost after system shutdown.

Procedure to replace the MEMORY board:



Some inverter parts may be subject to voltages that could be hazardous for the operator.

1. Before performing any work on the inverter, refer to “Inverter total de-energization and safe access” chapter on this manual to know all the necessary step to safely operate on the inverter.
2. Open the wiring box front cover **07**.
3. Extract the communication and control board **28** as explained in the chapter “Communication and control board”.
4. Remove the MEMORY board to be replaced **45**.
5. Install the new MEMORY board .

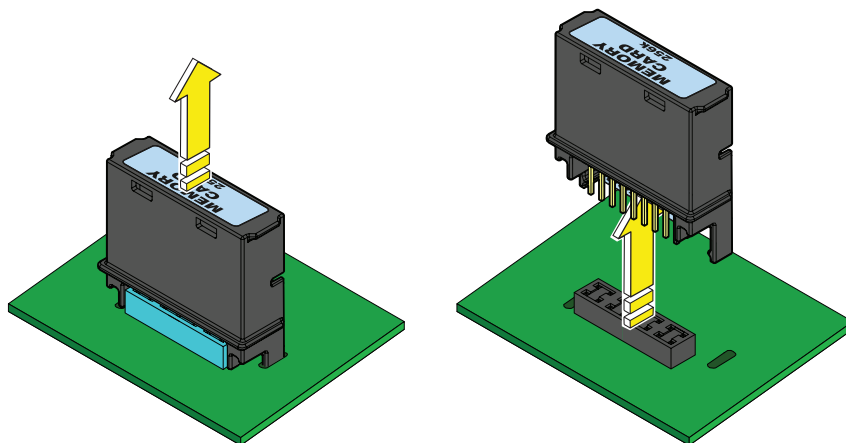

6. Close the wiring box front cover **07**.
7. Re-commission the inverter.

Replacement of the COMM RS485 board

44

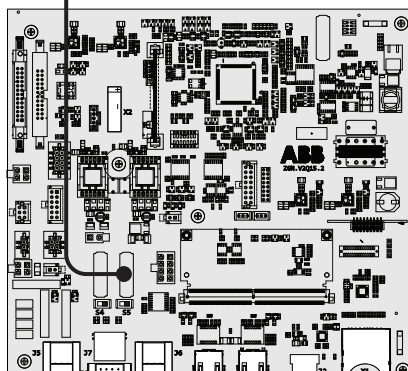

Replacing the COMM RS485 board is carried out on the wiring box **02** and may be necessary in case of communication issues on RS485 line.

Procedure to replace the COMM RS485 board:



Some inverter parts may be subject to voltages that could be hazardous for the operator.

1. Before performing any work on the inverter, refer to “Inverter total de-energization and safe access” chapter on this manual to know all the necessary step to safely operate on the inverter.
2. Open the wiring box front cover **07**.
3. Extract the communication and control board **28** as explained in the chapter “Communication and control board”.
4. Remove the COMM RS485 board to be replaced **44**.
5. Install the new COMM RS485 board .

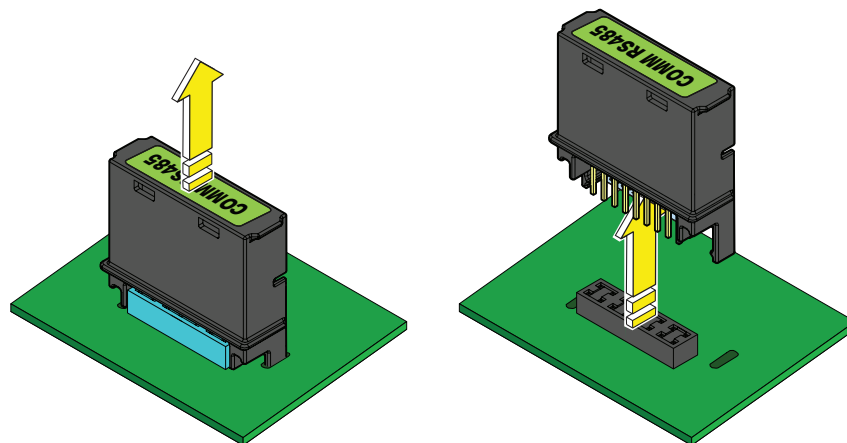

6. Close the wiring box front cover **07**.
7. Re-commission the inverter.

Replacement of the buffer battery

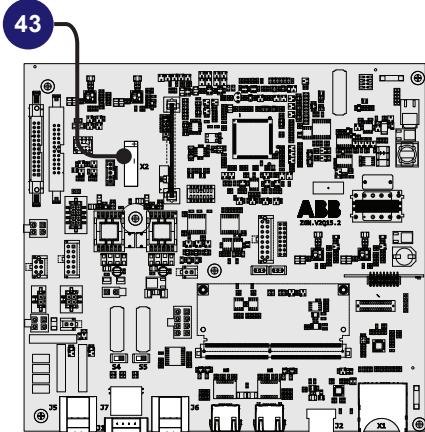

Some inverter parts may be subject to voltages that could be hazardous for the operator.

Replacing the buffer battery **43** is carried out on the wiring box **02** and may be necessary in the following circumstances:

1. LED error signal
2. Reset of the date and time settings

The battery is of the **CR2032** type and is installed on the communication and control board **28**.

Procedure to replace the COMM RS485 board:

1. Before performing any work on the inverter, refer to “Inverter total de-energization and safe access” chapter on this manual to know all the necessary step to safely operate on the inverter.
2. Open the wiring box front cover **07**.
3. Extract the communication and control board **28** as explained in the chapter “Communication and control board”.
4. Remove the buffer battery **43** to be replaced
5. Install the new battery, taking care to handle it with insulating gloves in order not to compromise the charge and respecting the polarity shown on the diagram on the communication and control board **28**

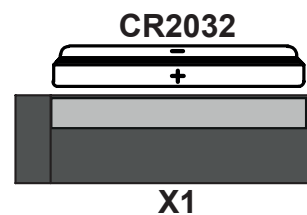
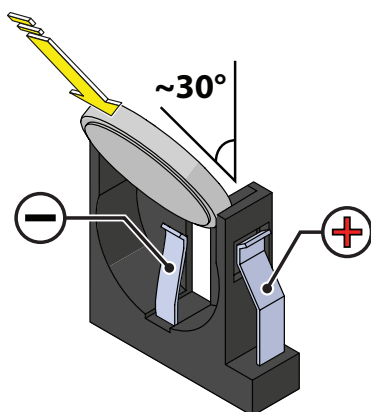

6. Reconnect all the input strings and start the inverter.

Verification of ground leakage

In the presence of anomalies or report of ground fault (where provided), there may be a ground leakage from the PV generator (DC side).

To check this, measure the voltage between the positive pole and ground and between the negative pole (of the PV generator) and ground using a voltmeter whose input accepts a voltage sufficient for the dimensions of the photovoltaic generator.

Behaviour of a system without leakage



All the following activities must be performed wearing the PPE and using appropriate measuring devices.

Due to the capacitive effect of the PV generator, during the first moments that the voltmeter is connected between one of the two poles and ground, it will measure a voltage of about $V_{oc}/2$, which will tend to stabilize to around 0V if there is no ground leakage, as shown in the graph below:

The internal resistance of the voltmeter tends to zero the voltage present on the PV generator due to the capacitive effect.

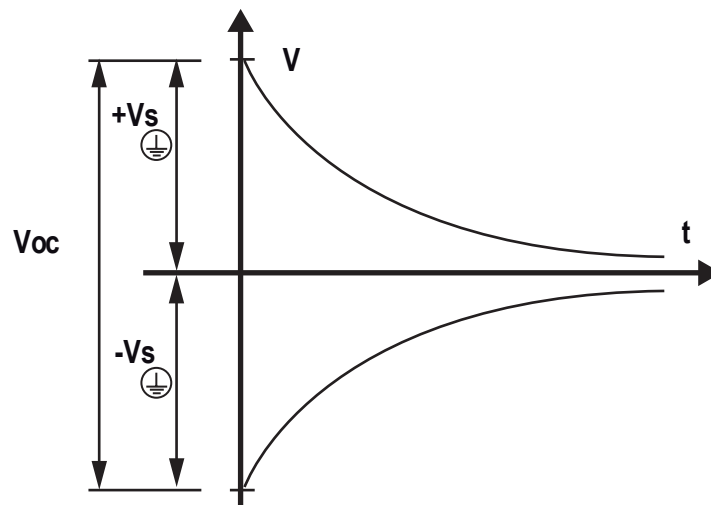

How to make the measurement:

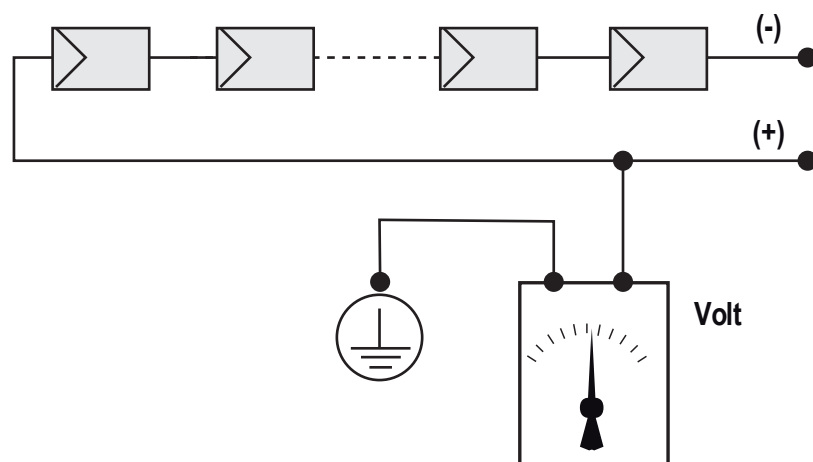

Behaviour of a system with leakage



All the following activities must be performed wearing the PPE and using appropriate measuring devices.

If the voltage measured between one of the two poles and ground does not tend to 0V and stabilizes on a value, there is a ground leakage from the PV generator.

Example: When the measurement is made between positive pole and ground, a voltage of 200V is measured.

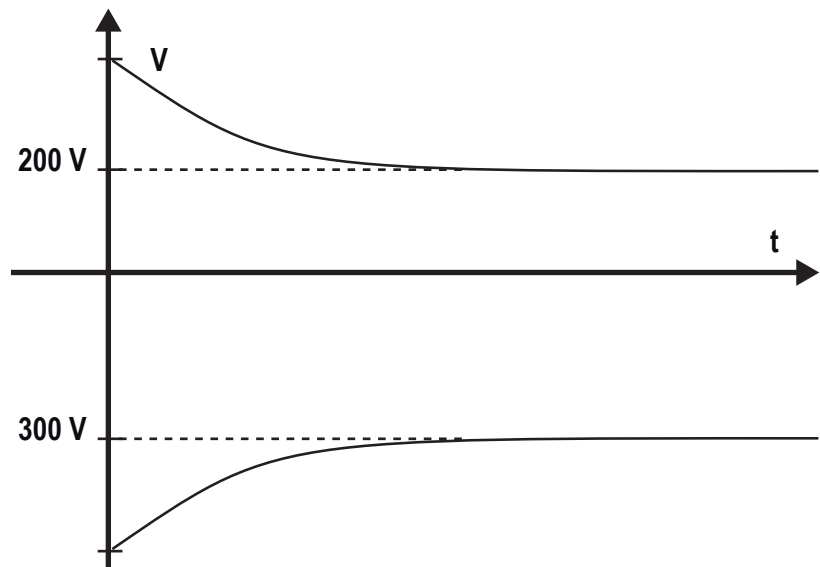

This means that if the system is made up of 10 modules in series and each one supplies 50V, the leakage can be located between the 4th and 5th PV module.

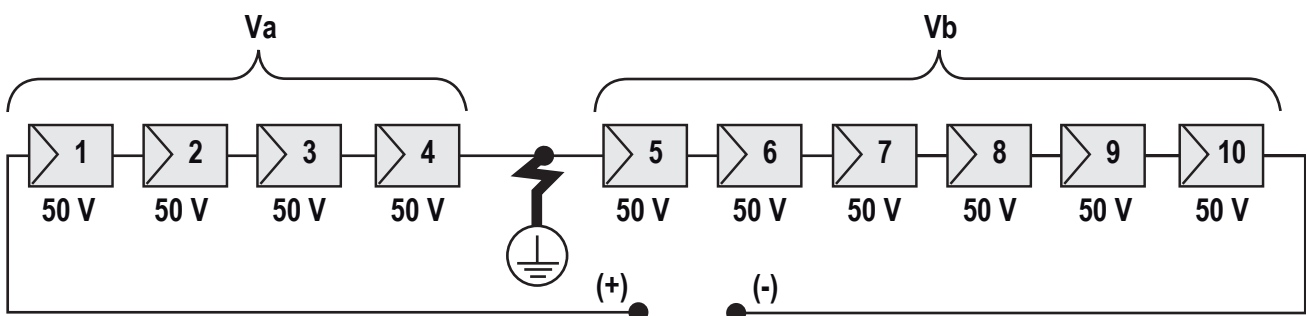

V_a = voltage measured between + pole and \oplus = 200V

V_b = voltage measured between - pole and \oplus = 300V

In all measurements with \oplus , the ground of the inverter is indicated.

Measuring the isolation resistance of the PV generator.



The operator must always use the personal protective equipment (PPE) required by the laws of the country of destination and whatever is provided by their employer.

To measure the isolation resistance of the PV generator compared to ground (⊕), the two poles of the PV generator must be short-circuited (using a suitable sized switch).



Use of inappropriate sized switch could cause risk of fire or electric arc! Use only 1500V rated switch!

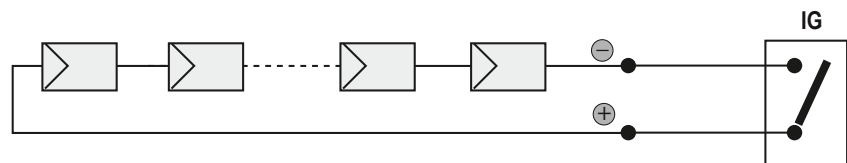

Once the short-circuit has been made, measure the isolation resistance (R_{iso}) using a megohmmeter positioned between the two shorted poles and ground (of the inverter).

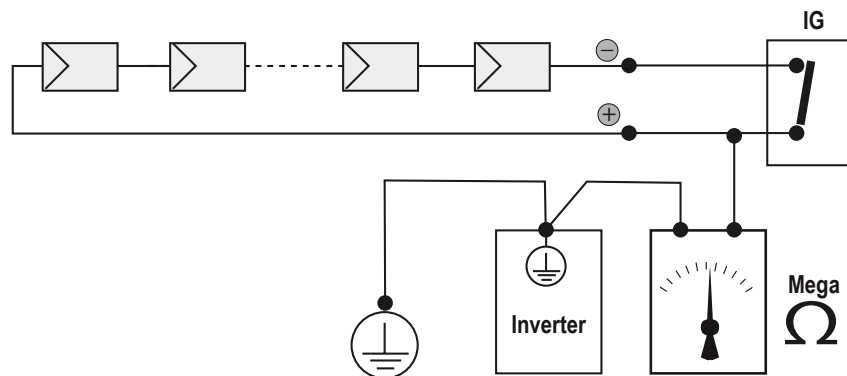

If the measured isolation resistance (R_{iso}) is less than 33 kOhm, the inverter may not connect to the grid because of low isolation of the PV generator to ground.



The isolation resistance can be affected by the environmental conditions the PV generator is in (E.g.: PV modules wet from damp or rain), and therefore the measurement must be made immediately after the anomaly is detected

Storage and dismantling

Storage of the equipment or prolonged stop

If the equipment is not used immediately or is stored for long periods, check that it is correctly packed and contact **FIMER** for storage instructions.

The equipment must be stored in well-ventilated indoor areas having no characteristics that could damage the components of the equipment.

Restarting after a long or prolonged stop requires a check and, in some cases, the removal of oxidation and dust that will also have settled inside the equipment if not suitably protected.

Dismantling, decommissioning and disposal

FIMER is not responsible for any loss of the equipment, or part of it, which does not take place on the basis of the regulations and laws in force in the country of installation.



The symbol of the cancelled bin (where present) indicates that the product must not be disposed of with domestic waste at the end of its useful life.

This product must be delivered to the waste collection point of the local community for recycling.

For further information, refer to the public body responsible for waste disposal in the country.

Inappropriate disposal of waste can have a negative impact on the environment and human health owing to potentially dangerous substances. By cooperating in the correct disposal of this product, you contribute to the reuse, recycling and recovery of the product, and the protection of our environment.

Dispose of the various types of materials that the parts of the equipment consist of in dumps that are suitable for the purpose.

COMPONENT	MATERIAL OF CONSTRUCTION
Frame, brackets, supports	Arc-welded steel FE37, aluminium
Casing or covers	ABS, plastic
Paint	Polyester Resin
Gaskets and seals	Rubber / Teflon / Viton
Electrical cables	Copper / Rubber
Cable trays	Polyethylene / Nylon
Batteries	Nickel / Lead/ Lithium

Port and network services used by the inverter

IP Network Services

Any network connected to the inverter must allow traffic to pass on the following ports. Network firewall rules (if present) must allow responses to the inverter over existing TCP connections.

Direction	Service/Port	Protocol	Description
In	ssh/22	Tcp	For local debugging by FIMER service personnel, the inverter utilizes encrypted SSH. To allow service personnel local access to the inverter.
Out	domain/53	Tcp/udp	The inverter must be able to resolve domain names, to ensure scalability and dynamic changes on the Internet (DNS). (required)
Out	https/443	Tcp	As an HTTP client, the inverter uses SSL/TLS protocol connections to Aurora Vision® servers for secure communication. The inverter uses this port for all services, including data transmission, firmware upgrade, configuration management, and remote command transmission. (required)
Out	dhcp/67, dhcp/68	Udp	If DHCP service is not available, static network information must be assigned to the inverter (preferred)
Out	ntp/123	Udp	The inverter uses this port for network time services (NTP). (preferred)
Out	modbus/502	Tcp	The inverter offer a Modbus TCP server connection on this port.
Out	dns-sd/5353	Udp	The inverter uses this protocol to resolve the local IP address.
Out	http/80	Tcp	As an HTTP client, the inverter uses this protocol to offer local connection.

Network Hosts

The inverter will connect to the following hosts. Some servers owned by FIMER, and others are customer or ISP servers. Servers listed as owned by “Customer IT/ISP” must be configured in the inverter using either DHCP or as static network information.

Host	Purpose	Port	Owner/Manager
platform.auroravision.net	Data, configuration	TCP:443	FIMER
gw1.auroravision.net and/or apt.fatspaniel.net	Inverter firmware upgrade	TCP:443	FIMER
Site dependent	DHCP (optional)	UDP:67, UDP:68	Customer IT/ISP
Site dependent	DNS	UDP:53, TCP:53	Customer IT/ISP

Inverter network configuration

The inverter requires a valid network configuration in order to operate. This information can either be provided by a DHCP server provided by the customers network (the default), or the inverter can be configured with static network information. Regardless of how the inverter is configured, the following information is required.

Configuration	Purpose
IP Address	Allows the inverter to take part in the local network. This does not need to be a public IP address. In most cases this is a private IP address.
Subnet mask	Used to determine if two computers are on the same network.
Gateway	The IP address of the computer which will forward network traffic from the local network to an external network
DNS Server	The IP address(es) of the computer(s) which resolve domain names.

Contact us

www.fimer.com



For more information
please contact
your local FIMER
representative or visit:

fimer.com

We reserve the right to make technical changes or modify the contents of this document without prior notice. With regard to purchase orders, the agreed particulars shall prevail. FIMER does not accept any responsibility whatsoever for potential errors or possible lack of information in this document.

We reserve all rights in this document and in the subject matter and illustrations contained therein. Any reproduction, disclosure to third parties or utilization of its contents – in whole or in parts – is forbidden without prior written consent of FIMER. Copyright© 2020 FIMER. All rights reserved.