



# Central inverter

## PVS980-58

The new high power FIMER central inverter raises the performance, cost efficiency and ease of installation to new levels. The inverters are aimed at system integrators and end users who require high-performance solar inverters for large photovoltaic (PV) power plants and are optimized for multi-megawatt power plants.

**From 4348 to 5000 kVA**

### World's leading inverter platform

Like other FIMER central inverters, the PVS980-58 has been developed on the basis of decades of experience in the industry and proven technology platform. Unrivalled expertise from the world's market and technology leader in frequency converters is the hallmark of this solar inverter series.

The PVS980-58 inverter is one of the most efficient and cost-effective ways of converting the direct current (DC) generated by solar modules into high quality and CO<sub>2</sub>-free alternating current (AC) that can be fed into the power distribution network.

### PVS980-58 central inverters from FIMER

FIMER PVS980-58 central inverters are ideal for large PV power plants. The high DC input voltage, high efficiency, proven components, compact and modular design and a host of life cycle services ensure FIMER PVS980-58 central inverters

provide a rapid return on investment. New extended power range along with fast site installation raises the total cost efficiency to a new level.

### Highlights

- High total performance
- Modular product design
- High DC input voltage up to 1500 V<sub>DC</sub>
- Extensive DC and AC side protection
- Easy to commission, no separate chiller installation
- Fast and easy AC coupling to transformer by busbars
- Versatile design for large-scale PV plants to minimize system costs
- Complete range of industrial data communication options, including remote monitoring
- Life cycle service and support through FIMER's extensive global service network



## Maximum energy revenues

FIMER central inverters have a high total efficiency. Precise, optimized system control and maximum power point tracking (MPPT) combined with the unit's highly efficient power converter design deliver the maximum energy from the PV modules to the power distribution network. For end users, this generates the highest possible revenues from the energy sales.

### Patented cooling system

PVS980-58 inverter utilizes patented self-contained cooling system in power module cooling. This innovative, low-maintenance cooling solution is also used in other industrial applications and is designed for demanding environments. The cooling system needs no separate commission and it ensures outstanding endurance.

### Compact and modular design

PVS980-58 inverters are designed for fast and easy installation. The industrial design and modular platform provide a wide range of options, such as remote monitoring, fieldbus connection and modular and flexible DC input connections. The integrated DC cabinet saves space and costs as the solar array junction boxes can be connected directly to the fused busbars in the DC cabinet. PVS980-58 inverters are customized for the needs of end users and will be available with short

delivery times.

### Versatile design for large-scale PV plants to minimize system costs

FIMER's PVS980-58 central inverter enables system integrators to design PV power plants that use the optimum combination of inverters with different power ratings. Equipped with extensive electrical and mechanical protection, the inverters are engineered to provide a long and reliable service life of at least 25 years.

### Advanced grid support features

The PVS980-58 software includes all the latest grid support and monitoring features, including active power limitation, fault ride through (FRT) with current feed-in and reactive power control. Active and reactive power output can be controlled by an external control system or automatically by the inverter.

All grid support functions are parameterized, allowing easy adjusting for local utility requirements. FIMER central inverters are also able to support grid stability at night by providing reactive power with the DC input disconnected.

## Technical data and types

Product Type designation, PVS980-58	PVS980-58 4.3 MVA -4348kVA-I	PVS980-58 4.6 MVA -4565kVA-J	PVS980-58 4.8 MVA -4782kVA-K	PVS980-58 5.0 MVA -5000kVA-L
<b>Input (DC)</b>				
Maximum recommended input power ( $P_{PV,max}$ ) <sup>1)</sup>	8696 kWp	9130 kWp	9564 kWp	10000 kWp
Maximum DC short circuit current			16 kA	
Maximum operational DC current			5300 A	
Maximum operational DC voltage ( $U_{max(DC)}$ ) <sup>2)</sup>			1500 V	
DC voltage range for maximum power ( $U_{dc, mpp}$ ) @ -20 to +25 °C	850 to 1350 V	893 to 1350 V	935 to 1350 V	978 to 1350 V
DC voltage range for maximum power ( $U_{dc, mpp}$ ) @ 35 °C	850 to 1250 V	893 to 1250 V	935 to 1250 V	978 to 1250 V
DC voltage range for maximum power ( $U_{dc, mpp}$ ) @ 50 °C	850 to 1100 V	893 to 1100 V	935 to 1100 V	978 to 1100 V
Number of MPPT trackers			1	
Number of protected DC inputs <sup>3)</sup>			20-36 (+/-)	
<b>Output (AC)</b>				
Power @ 25 °C	4348 kVA	4565 kVA	4782 kVA	5000 kVA
AC current @ 25 °C			4184 A	
Power @ 35 °C	4229 kVA	4441 kVA	4652 kVA	4864 kVA
AC current @ 35 °C			4070 A	
Power ( $S_{N(AC)}$ ) @ 50 °C	3845 kVA	4037 kVA	4229 kVA	4421 kVA
AC current ( $I_{N(AC)}$ ) @ 50 °C			3700 A	
Nominal output voltage ( $U_{N(AC)}$ ) <sup>4)</sup>	600 V	630 V	660 V	690 V
Output frequency <sup>5)</sup>			50/60 Hz	
Harmonic distortion, current <sup>6)</sup>			< 3%	
Maximum AC short circuit current from network			80 kA (1 s RMS)	
Distribution network type <sup>7)</sup>			TN and IT	
<b>Efficiency</b>				
Maximum <sup>8)</sup>			98.8%	
Euro-eta <sup>8)</sup>			98.6%	
CEC efficiency <sup>9)</sup>			98.5%	
<b>Power consumption</b>				
Own consumption in normal operation			5000 W	
Maximum standby operation consumption			460 W	
Auxiliary voltage type			external <sup>10)</sup>	

<sup>1)</sup> DC/AC ratio close to 2.0 might shorten maintenance intervals

<sup>2)</sup> Throughout the temperature range

<sup>3)</sup> Standard 24 DC inputs with negative grounding, fuses on positive pole only

<sup>4)</sup> +/- 10%, consult FIMER for detailed information

<sup>5)</sup> +/- 10 Hz

<sup>6)</sup> At nominal power

<sup>7)</sup> Inverter side must be IT type

<sup>8)</sup> Without auxiliary power consumption at min  $U_{dc}$

<sup>9)</sup> Rounded according to CEC rules

<sup>10)</sup> Internal available as an option

**Technical data and types**

Product Type designation, PVS980-58	PVS980-58 4.3 MVA -4348kVA-I	PVS980-58 4.6 MVA -4565kVA-J	PVS980-58 4.8 MVA -4782kVA-K	PVS980-58 5.0 MVA -5000kVA-L
<b>Dimensions and weight</b>				
Width/Height/Depth, mm (W/H/D)	5600/2200/1600			
Weight appr.	Max. 6000 kg			
<b>Environmental limits</b>				
Degree of protection	IP55 /Type 3R, sand test certified.			
Ambient temp. range <sup>11)</sup>	-20 ... +50 °C			
Maximum ambient temperature <sup>12)</sup>	+60 °C			
Relative humidity	4 ... 100%			
Maximum altitude (above sea level) <sup>13)</sup>	4000m <sup>14)</sup>			
Maximum noise level	84 dBA <sup>15)</sup>			
<b>Protection</b>				
Ground fault monitoring	Yes			
Grid monitoring	Yes			
Anti-islanding	Yes			
DC reverse polarity	Yes			
AC and DC short circuit and over current	Yes			
AC and DC over voltage and temperature	Yes			
<b>User interface and communications</b>				
Local user interface	Local control panel			
Analog inputs/outputs	2/1 as standard, extendable as engineered option			
Digital inputs/relay outputs	7/1 as standard, extendable as engineered option			
Fieldbus connectivity	Modbus, Profinet, Ethernet IP <sup>16)</sup>			
<b>Product compliance</b>				
Safety and EMC	CE Declaration of Conformity, IEC62109-1, IEC62109-2, UL62109, UL1741, CSA C22.2 No. 107.1-16, RCM, IEC62920			
Characteristics	IEC60068-2-1, -2, -14, -30, IEC61683, EN50530, IEC61727, IEC62116, IEC62910, ANSI/UL1998			
Grid codes	IEEE1547-2003, VDE-AR-N 4110, UL1741SA, PO12.2 / NTS, G99, CEA (India), DEWA, Chile			
Grid support and grid functions	Reactive power compensation, Power reduction, LVRT, HVRT, FqRT			

<sup>11)</sup> -40 °C as option

<sup>12)</sup> Power limiting after 50 °C

<sup>13)</sup> Possible power limiting above 1000 m, depending on temperature

<sup>14)</sup> Standard device up to 2000m, up to 4000m as an option

<sup>15)</sup> At partial power typically < 75 dBA

<sup>16)</sup> More communication options as engineered option

**PVS980-58 central inverter block diagram**

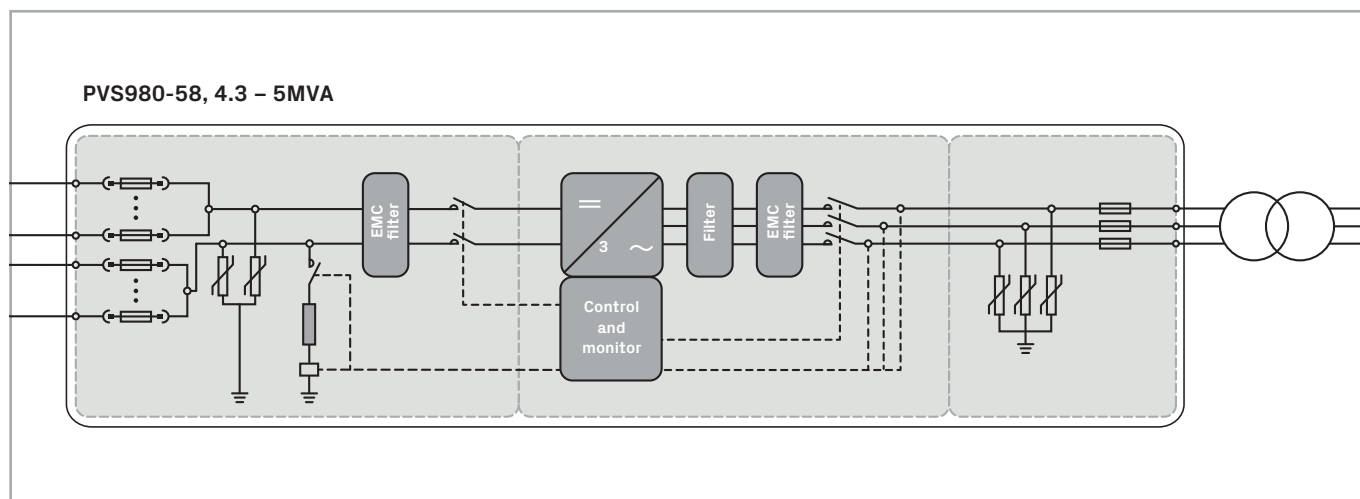

# Central inverter

## PVS980-58 from 4348 to 5000 kVA



### High total performance

- High efficiency
- Low auxiliary power consumption
- Innovative controlled cooling
- Efficient maximum power point tracking
- Long and reliable service life of at least 25 years

### Outstanding endurance for outdoor use

- Water- and dustproof outdoor enclosure
- Designed to withstand the toughest environments
- Long and reliable service life following the FIMER life cycle model

### Modular industrial design

- Compact and easy-to-maintain product design
- Fast and easy installation
- Integrated and flexible DC input section

### Life cycle service and support

- FIMER's extensive global service network
- Extended warranties
- Service contracts
- Technical support throughout the service life

### Patented cooling system

- Self-contained, thermosiphon cooled power modules
- Liquid-cooled inverter power ratings with the simplicity of air cooling
- No fillable liquids, pumps, valves, inhibitors or leaks
- Low maintenance

### Versatile design for largescale PV plants

- Fast AC connection with busbars, no AC cable pulling
- Integrated DC connection with variable number of inputs
- Wide standard option palette for tailoring

### Minimizes system costs

- Very high output power and small footprint allows cost efficient power block designs
- 1500 V<sub>dc</sub> system voltage
- Wide ranged and highly efficient MPPT algorithm
- Integrated protection to minimize external components
- Fast and easy installation and commissioning

### Wide communication options

- Complete range of industrial data communication options for SCADA connections
- Ethernet/Internet Protocol
- Remote monitoring

### Comprehensive simulation models

- PSS/E
- PSCAD
- DigSilent

## Data communication principle for PVS980-58 central inverter

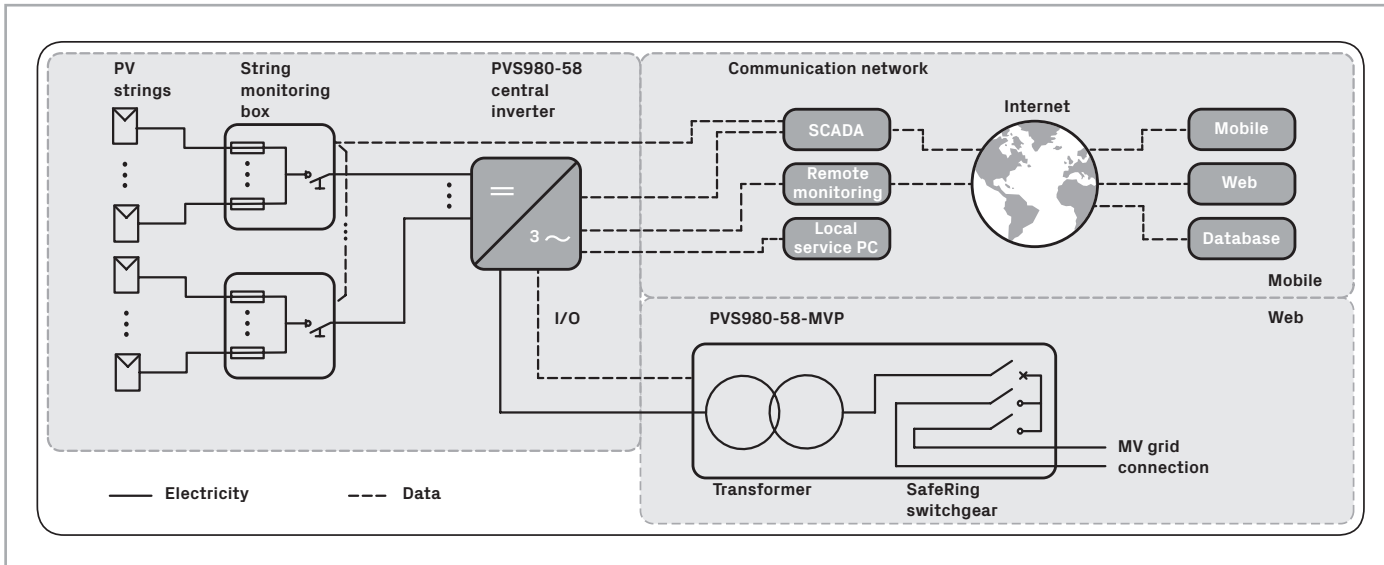

### Options

- Integrated and flexible DC input extension
- AC breaker
- Heavy duty (Type 1) surge protection
- Various internal auxiliary power supply options up to 10kVA for customer use
- Floating DC
- Fieldbus and Ethernet connections
- Current measurement to each DC input
- High altitude version
- Low temperature version
- Warranty extensions
- Solar inverter care contracts

### Related products

- Integrated products, pad mounted- or compact skid solutions
- String monitoring junction boxes
- Remote monitoring solutions

### Support and service

FIMER supports its customers with a global service network and provides a complete range of life cycle services from installation and commissioning to preventative maintenance, spare parts, repairs and recycling.



For more information please contact your local FIMER representative or visit:

[fimer.com](http://fimer.com)

We reserve the right to make technical changes or modify the contents of this document without prior notice. With regard to purchase orders, the agreed particulars shall prevail. FIMER does not accept any responsibility whatsoever for potential errors or possible lack of information in this document.

We reserve all rights in this document and in the subject matter and illustrations contained therein. Any reproduction, disclosure to third parties or utilization of its contents – in whole or in parts – is forbidden without prior written consent of FIMER. Copyright© 2021 FIMER. All rights reserved.

