



## **Bidirectional converter**

### **PVS980-58BC**

FIMER bidirectional converter, PVS980-58BC, is aimed at large-scale grid connected energy storage applications. The converters are available from 3478 kVA up to 5000 kVA. PVS980-58BC bidirectional converter is based on the world's leading converter platform used also in FIMER solar inverters ensuring high performance, reliability, and availability of global service support

### World's leading converter platform

Like FIMER inverters, PVS980-58BC bidirectional converter has been developed based on decades of experience in the industry and proven technology platform. Unrivaled expertise from the world's market and technology leader in frequency converters is the hallmark of the PVS980-58 series.

The PVS980-58BC converter is one of the most efficient and cost-effective ways of converting the direct current (DC) generated by batteries into high quality and CO<sub>2</sub>-free alternating current (AC) that can be fed into the power distribution network.

### PVS980-58 bidirectional converter from FIMER

FIMER PVS980-58BC bidirectional converters are ideal for multi-megawatt energy storage systems, providing maximum grid stability for power plants with intermittent energy sources.

For power plants combining photovoltaics and energy storage, the common platform shared with PVS980-58 solar inverter and PVS980-58BC bidirectional converters brings synergies in both the availability of service and support personnel and the spare part logistics

### Highlights

- High total performance
- Modular product design
- High DC input voltage up to 1500 V<sub>DC</sub>
- Extensive DC and AC side protection
- Easy to commission, no separate chiller installation
- Fast and easy AC coupling to transformer by busbars
- Versatile design for large-scale plants to minimize system costs
- Complete range of industrial data communication options, including remote monitoring
- Life cycle service and support through FIMER's extensive global service network



## Maximum energy revenues

FIMER bidirectional converters have a high total efficiency. Precise, optimized system control combined with the unit's highly efficient power converter design deliver the maximum energy from the batteries to the power distribution network. For end users, this generates the highest possible revenues from the energy sales.

### Patented cooling system

PVS980-58BC converters utilizes patented self-contained cooling system in power module cooling. This innovative, low-maintenance cooling solution is also used in other industrial applications and is designed for demanding environments.

The cooling system needs no separate commission and it ensures outstanding endurance.

### Compact and modular design

PVS980-58BC converters are designed for fast and easy installation. The industrial design and modular platform provide a wide range of options, such as remote monitoring, fieldbus connection and modular and flexible DC input connections. PVS980-58BC converters are customized for the needs of end users and will be available with short delivery times

### Versatile design for large-scale Projects to minimize system costs

FIMER's PVS980-58BC bidirectional converters enables system integrators to design power plants that use the optimum combination of converters with different power ratings. Equipped with extensive electrical and mechanical protection, the inverters are engineered to provide a long and reliable service life of at least 25 years.

### Advanced grid support features

The PVS980-58BC software includes all the latest grid support and monitoring features, including active power limitation, fault ride through (FRT) with current feed-in and reactive power control. Active and reactive power output can be controlled by an external control system or automatically by the converter.

All grid support functions are parameterized, allowing easy adjusting for local utility requirements. FIMER bidirectional converters are also able to support grid stability at night by providing reactive power with the DC input disconnected.

## Technical data and types

Product	PVS980-58BC-3478-E	PVS980-58BC-3767-F	PVS980-58BC-4057-G	PVS980-58BC-4348-I	PVS980-58BC-4565-J	PVS980-58BC-4782-K	PVS980-58BC-5000-L
---------	--------------------	--------------------	--------------------	--------------------	--------------------	--------------------	--------------------

### Input (DC)

DC voltage operating range, (UDC) <sup>1)</sup>	680 to 1500 V	737 to 1500 V	794 to 1500 V	850 to 1500 V	893 to 1500 V	935 to 1500 V	978 to 1500 V
Full power DC voltage range, (UDC) a 50 °C <sup>1)</sup>	680 to 880 V	737 to 950 V	794 to 1020 V	850 to 1100 V	893 to 1100 V	935 to 1100 V	978 to 1100 V
Max DC short circuit withstand	73 kApeak, 17 MA2s, external aR fuses required between converter and BES						
Number of protected DC inputs <sup>3)</sup>	20						
Maximum operational DC current	5300 A						
Maximum operational DC voltage (U <sub>max</sub> (DC)) <sup>2)</sup>	1500 V						

### Output (AC)

Power @ 25 °C	3478 kVA	3767 kVA	4057 kVA	4348 kVA	4565 kVA	4782 kVA	5000 kVA
AC current @ 25 °C	4184 A						
Power @ 35 °C	3383 kVA	3665 kVA	3947 kVA	4229 kVA	4441 kVA	4652 kVA	4864 kVA
AC current @ 35 °C	4070 A						
Power @ 50 °C	3075 kVA	3332 kVA	3589 kVA	3845 kVA	4037 kVA	4229 kVA	4421 kVA
AC current @ 50 °C	3700 A						
Nominal output voltage (UN (AC)) <sup>4)</sup>	480 V	520 V	560 V	600 V	630 V	660 V	690 V
Output frequency <sup>5)</sup>	50/60 Hz						
Harmonic distortion, current <sup>6)</sup>	< 3%						
Maximum AC short circuit current from network	66 kA (1 s RMS)						
Power factor	Four quadrant						
Distribution network type <sup>7)</sup>	TN and IT						

### Efficiency

Maximum <sup>8)</sup>	98.8%
Euro-eta <sup>8)</sup>	98.6%
CEC efficiency <sup>9)</sup>	98.5%

### Power consumption

Own consumption in normal operation	5000 W
Maximum standby operation consumption	460 W
Auxiliary voltage type	external <sup>10)</sup>

1) Minimum DC (UDC,min) for UN(AC) and power factor=1. The minimum DC voltage depends on AC voltage and power factor. The AC dependency follows formula  
 $UDC,min = UAC * \sqrt{2} * 1.002$

2) Throughout the temperature range

3) Standard 20 DC inputs.

4) +/- 10%, consult FIMER for detailed information

5) +/- 10 Hz

6) At nominal power

7) Inverter side must be IT type

8) Without auxiliary power consumption at min UDC

9) Rounded according to CEC rules

10) Internal available as an option

## Technical data and types

Product	PVS980-	PVS980 -	PVS980-	PVS980-	PVS980-	PVS980-	PVS980-
Type designation, PVS980-58BC	58BC-3478-F	58BC-3767-G	58BC-4057-H	58BC-4348-I	58BC-4565-J	58BC-4782-K	58BC-5000-L

### Dimensions and weight

Width/Height/Depth, mm (W/H/D) 5694/2350/1634

Weight appr. Max. 6000 kg

### Environmental limits

Degree of protection IP55 Enclosure (IP65 Electronics Section as option)

Ambient temp. range <sup>11)</sup> -20 ... +50 °C

Maximum ambient temperature <sup>12)</sup> +60 °C

Relative humidity 4 ... 100%

Maximum altitude (above sea level) <sup>13)</sup> 4000m <sup>14)</sup> Deration to be considered

Maximum noise level 84 dBA <sup>15)</sup>

### Protection

Ground fault monitoring Yes

Grid monitoring Yes

Anti-islanding Yes

DC reverse polarity Yes

AC and DC short circuit and over current Yes

AC and DC over voltage and temperature Yes

### User interface and communications

Local user interface Local control panel

Analog inputs/outputs 2/1 as standard, extendable as engineered option

Digital inputs/relay outputs 7/1 as standard, extendable as engineered

option Fieldbus connectivity Modbus, Profinet, Ethernet IP <sup>16)</sup>

### Product compliance

Safety and EMC CE Declaration of Conformity, IEC 62477-1

Characteristics IEC60068-2-1,-2,-14,-30, IEC61683, EN50530, IEC61727, IEC62116, IEC62910

Grid codes IEC

Grid support and grid functions Reactive power compensation, Power reduction, LVRT, HVRT, FqRT

11) -40 °C as an option

12) Power limiting after 51 °C as an optional model

13) Possible power limiting above 1000 m, depending on temperature

14) Standard device up to 2000m, up to 4000m as an option, considering the deration

15) At partial power, typically < 75 dBA

16) More communication options as an engineered option

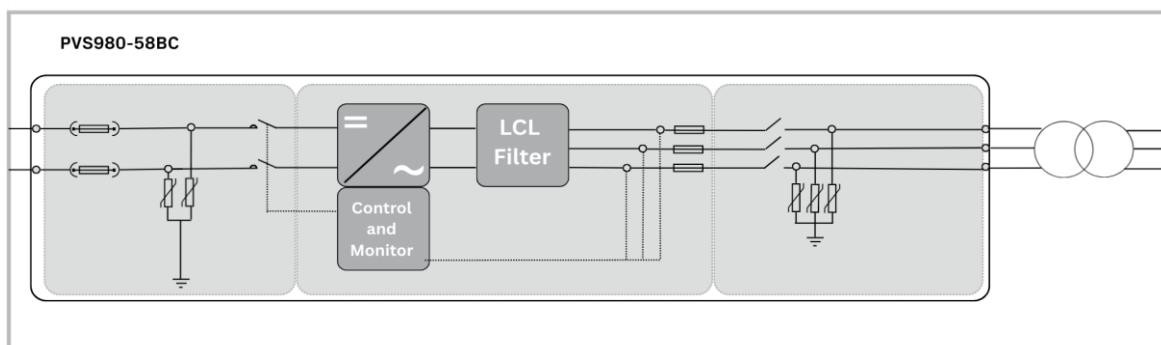

# Bidirectional Converters

## PVS980-58BC from 3478 to 5000 kVA



### High total performance

- High efficiency
- Low auxiliary power consumption
- Innovative controlled cooling
- Long and reliable service life of at least 25 years

### Outstanding endurance for outdoor use

- Water- and dustproof outdoor enclosure
- Designed to withstand the toughest environments
- Long and reliable service life following the FIMER life cycle model

### Modular industrial design

- Compact and easy-to-maintain product design
- Fast and easy installation
- Integrated and flexible DC input section

### Life cycle service and support

- FIMER's extensive global service network
- Extended warranties
- Service contracts
- Technical support throughout the service life

### Patented cooling system

- Self-contained, thermosyphon cooled power modules
- Liquid-cooled inverter power ratings with the simplicity of air cooling
- No fillable liquids, pumps, valves, inhibitors, or leaks
- Low maintenance

### Versatile design for largescale BESS plants

- Fast AC connection with AC cable
- Integrated DC connection with variable number of inputs
- Wide standard option palette for tailoring

### Minimizes system costs

- Very high output power and small footprint allows cost efficient power block designs
- 1500 V<sub>DC</sub> system voltage
- Integrated protection to minimize external components.
- Fast and easy installation and commissioning

### Wide communication options

- Complete range of industrial data communication options for SCADA connections
- Ethernet/Internet Protocol
- Remote monitoring

### Comprehensive simulation models

- PSS/E
- PSCAD
- DigSilent

## Battery energy storage system example with FIMER PVS980-58BC bidirectional converter

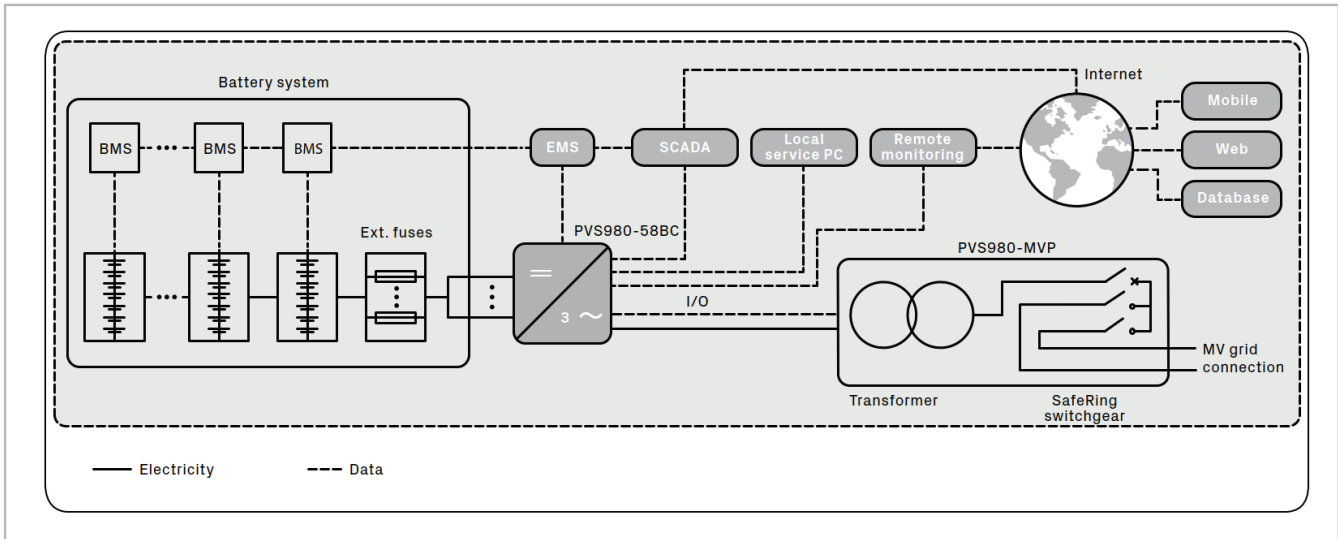

### Options

- Integrated and flexible DC input extension
- Heavy duty (Type 1) surge protection
- Various internal auxiliary power supply options up to 10kVA for customer use
- Floating DC
- Fieldbus and Ethernet connections
- High altitude version
- Low temperature version
- Warranty extensions
- Bidirectional PCS care contracts

### Related products

- Integrated products, pad mounted- or compact skid solutions
- Remote monitoring solutions

### Support and service

FIMER supports its customers with a global service network and provides a complete range of life cycle services from installation and commissioning to preventative maintenance, spare parts, repairs and recycling.



For more information please contact your local FIMER representative or visit:

[fimer.com](http://fimer.com)

We reserve the right to make technical changes or modify the contents of this document without prior notice. With regard to purchase orders, the agreed particulars shall prevail. FIMER does not accept any responsibility whatsoever for potential errors or possible lack of information in this document.

We reserve all rights in this document and in the subject matter and illustrations contained therein. Any reproduction, disclosure to third parties or utilization of its contents – in whole or in parts – is forbidden without prior written consent of FIMER. Copyright© 2021 FIMER.

