

# ABB inverter station

PVS800-IS – 1.645 to 4.156 MW



The ABB inverter station is a compact turnkey solution designed for large-scale solar power generation. The inverter station houses all equipment that is needed to rapidly connect ABB central inverters to a medium voltage (MV) transformer station.

01

01 ABB inverter station, PVS800-IS, 1.645 to 4.156 MW, with one or two PVS800-57B inverters in a compact and transportable 20-foot sea container.

## Turnkey solution for photovoltaic (PV) power plants

The ABB inverter station design capitalizes on ABB's long experience in the development and manufacture of secondary substations for electrical authorities and major end-users worldwide in conventional power transmission installations.

The station houses one or two ABB central inverters and embedded auxiliary power, monitoring and air filtration systems. It enables easy and rapid connection to a MV transformer station. Depending on the size of the PV power plant, several ABB inverter stations can be used to meet the capacity need.

## Proven design with long operating life

The housing is based on a standard, insulated, steel-framed 20-foot shipping container. The total package weighs only 11 metric tons with two inverters or 8 metric tons with one inverter. The optimized shipping container solution ensures cost-effective and safe transportability to the site. The station's optimized air circulation and filtering system together with thermal insulation enable operation in harsh temperature and humidity environments. The inverter station is designed for at least 25 years of operation.

## Highlights

- Proven technology and reliable components
- Standard and robust design
- Compact and transportable 20-foot sea container based design
- Protected working interior
- Modular and redundant system
- Easy connection to a MV station
- Extendable manufacturing footprint with fast deliveries
- Embedded auxiliary power distribution system
- Double-stage air pre-filtering for reduced maintenance
- Life cycle service and support through ABB's extensive global service network

## ABB inverter station

### Solar inverters

ABB's PVS800 central inverters are the result of decades of industry experience and the use of proven frequency converter technology. As such the central inverters provide a highly efficient and cost-effective way to convert the direct current generated by solar modules into high-quality and CO<sub>2</sub>-free alternating current. One or two ABB central inverters are used in the ABB inverter station. The inverters provide high efficiency conversion with low auxiliary power consumption.

### Easy connection to a MV station

The inverter station is easy to connect to any MV station configuration to match specific country or project requirements. ABB can provide oil or dry type transformers to go with a wide selection of switchgear configurations. Mounting options can be selected to match exactly the environmental and project-specific needs.

### Embedded auxiliary power distribution system

The embedded auxiliary power supply system supports needs of both inverter and MV stations. The system includes protected power supply terminals for stations accessories and signal terminals for alarm and control sensors.

The embedded auxiliary transformer can be included if external power supply is not available at the plant.



### Technical data and types

Type designation	PVS800-IS-1645kW-C	PVS800-IS-1732kW-C	PVS800-IS-3290kW-C	PVS800-IS-3464kW-C
<b>Input (DC)</b>				
Maximum input power ( $P_{PV,max}$ ) <sup>1)</sup>	2468 kW	2598 kW	2 × 2468 kW	2 × 2598 kW
DC voltage range, mpp ( $U_{DC,mpp}$ )	550 to 850 V	580 to 850 V	550 to 850 V	580 to 850 V
Maximum DC voltage ( $U_{DC,max}$ )	1000 V	1000 V	1000 V	1000 V
Maximum DC current ( $I_{DC,max}$ )	3700 A	3700 A	2 × 3700 A	2 × 3700 A
Number of protected DC inputs	20 to 24	20 to 24	2 × 20 to 24	2 × 20 to 24
Number of mpp trackers	1	1	2	2
<b>Output (AC)</b>				
Nominal AC output power ( $P_{AC,N}$ ) <sup>2)</sup>	1645 kW	1732 kW	2 × 1645 kW	2 × 1732 kW
Power at $\cos\varphi = 0.95$ <sup>2)</sup>	1562 kW	1645 kW	2 × 1562 kW	2 × 1645 kW
Maximum AC output power ( $P_{AC,max}$ ) <sup>3)</sup>	1975 kW	2078 kW	2 × 1975 kW	2 × 2078 kW
Nominal AC current ( $I_{AC,N}$ )	2500 A	2500 A	2 × 2500 A	2 × 2500 A
Nominal output voltage ( $U_{AC,N}$ )	380 V	400 V	380 V	400 V
Output frequency	50/60 Hz	50/60 Hz	50/60 Hz	50/60 Hz
Harmonic distortion, current <sup>4)</sup>	< 3%	< 3%	< 3%	< 3%
Power factor compensation	Yes	Yes	Yes	Yes

<sup>1)</sup> Inverter limits power to safe level

<sup>2)</sup> At 45 °C ambient temperature

<sup>3)</sup> At 20 °C ambient temperature

<sup>4)</sup> At nominal power

ABB inverter station design and power network connection

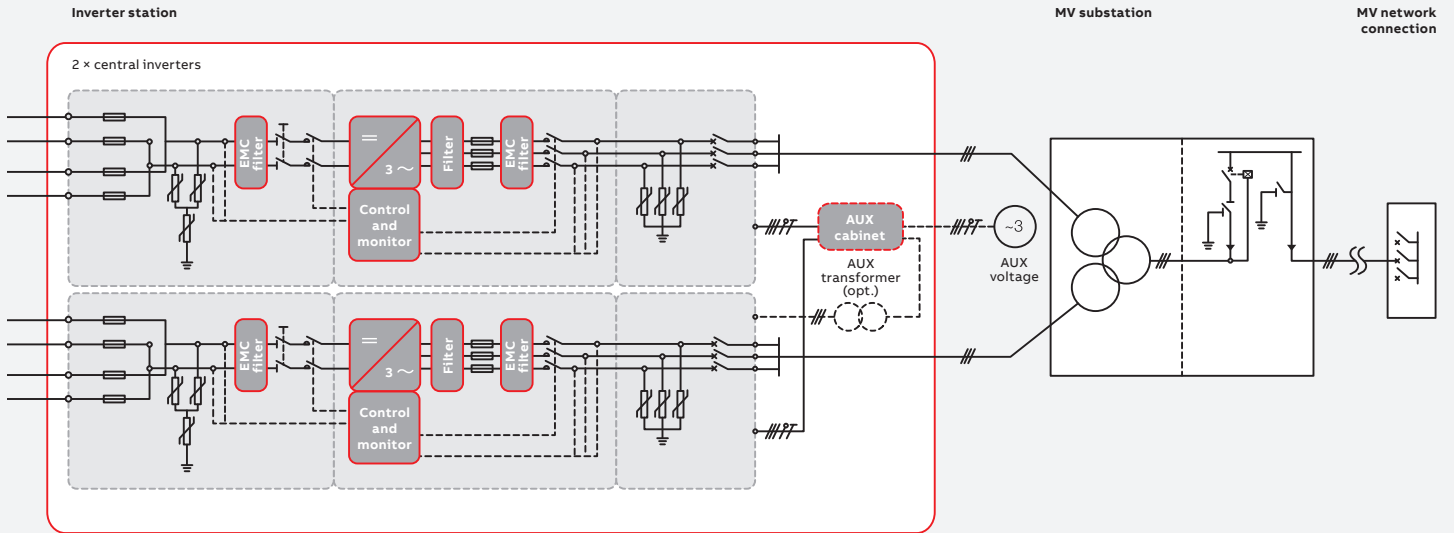

Technical data and types

Type designation	PVS800-IS-1645kW-C	PVS800-IS-1732kW-C	PVS800-IS-3290kW-C	PVS800-IS-3464kW-C
<b>Efficiency<sup>5)</sup></b>				
Maximum	98.5%	98.3%	98.4%	98.5%
Euro-eta	98.3%	98.4%	98.3%	98.4%
<b>Power consumption</b>				
Own consumption in operation <sup>6)</sup>	< 1800 W		< 3600 W	
Standby operation consumption <sup>6)</sup>	< 60 W		< 120 W	
External auxiliary voltage	3/N/PE AC 400 V 50 Hz		3/N/PE AC 400 V 50 Hz	
<b>Dimensions and weight</b>				
Width/Height/Depth, (W x H x D)	6058 x 2896 x 2438 mm		6058 x 2896 x 2438 mm	
Weight approx.	8 t		11 t	
<b>Environmental limits</b>				
Degree of protection <sup>7)</sup>	IP54		IP54	
Ambient temperature range (nominal ratings)	-20 °C to +45 °C		-20 °C to +45 °C	
Maximum ambient temperature <sup>8)</sup>	+55 °C		+55 °C	
Relative humidity, non condensing	15 to 95%		15 to 95%	

<sup>5)</sup> Efficiency without auxiliary power consumption at min. UDC

<sup>6)</sup> Without options and heating

<sup>7)</sup> After installation. During transportation IP55.

<sup>8)</sup> Power derating after 45 °C



02

02 View to internal parts of ABB inverter station

#### Accessories

- Solar array junction boxes with string monitoring
- Remote monitoring solutions
- Warranty extensions
- Solar inverter care contracts

#### Options

- Auxiliary transformer
- Upgrades to match environmental conditions

#### Support and service

ABB supports its customers with a dedicated service network in more than 60 countries and provides a complete range of life cycle services from installation and commissioning to preventative maintenance, spare parts, repairs and recycling.

For more information please contact your local ABB representative or visit:

[www.abb.com/solarinverters](http://www.abb.com/solarinverters)  
[www.abb.com](http://www.abb.com)

We reserve the right to make technical changes or modify the contents of this document without prior notice. With regard to purchase orders, the agreed particulars shall prevail. ABB does not accept any responsibility whatsoever for potential errors or possible lack of information in this document.

We reserve all rights in this document and in the subject matter and illustrations contained therein. Any reproduction, disclosure to third parties or utilization of its contents – in whole or in parts – is forbidden without prior written consent of ABB. Copyright © 2018 ABB. All rights reserved

