

Solar Inverters

Application Note

REACT-3.6/4.6-TL- BACKUP OUTPUT USE

Operation and Configuration



Power and productivity  
for a better world™



## **TABLE OF CONTENTS**

1. Scope and field of application
2. Operation principle
3. General recommendations
4. Specifications
5. Operation modes
  - 5.1 Selecting the mode: overview
  - 5.2 Operating conditions
  - 5.3 Mode configuration
  - 5.2 Control/signal from external logic
6. Priority loads relay

<b>Date</b>	<b>Notes</b>
18/03/16	First Release

## 1. Scope and field of application

The REACT system is provided with a source of alternating current (AC) available with an output on a dedicated terminal block, capable of feeding household utilities independently on the local power grid. This function is called a “backup”. The purpose of this document is to describe the operation and configuration of the backup function available for the models listed in the following table:

Models
REACT-UNO-3.6 -TL (with or without REACT-BATT-AP1)
REACT-UNO-4.6 -TL (with or without REACT-BATT-AP1)

## 2. Operation principle

Backup operation is an additional feature provided by the REACT system that allows the inverter to feed household utilities independently on the network of the local distributor. The system works based on the typical principle of Stand-Along systems non-connected to the network with, in addition, a backup energy supply due to the presence of batteries capable of supporting photovoltaic production to feed the users connected to the line dedicated to the backup.

The backup output can be used to feed loads (that will be defined as “priority loads”) connected either to the home network or to the dedicated line, or to feed utilities connected exclusively with the same backup line.

For a description of the operating principle and referring to the connection layout shown in the figure below, 3 types of loads can be identified in a system where the REACT device has been installed, namely:

- **Priority Loads:** utilities connected exclusively either to the electric system or to the backup line. Priority loads will be fed by the local network or by the backup line depending on the configuration of the connection circuit and on the type of relay used (see an example in Chapter 6).  
*Priority loads will never be fed simultaneously by the backup and the electric system.*
- **Backup Loads:** these loads are connected exclusively to the backup line, i.e. utilities independent on the local electric system. These utilities can be fed only in backup mode, when enabled for operation (e.g. Emergency lights).
- **Grid Loads:** these loads are connected exclusively to the electric system, therefore they are never fed by the backup output.

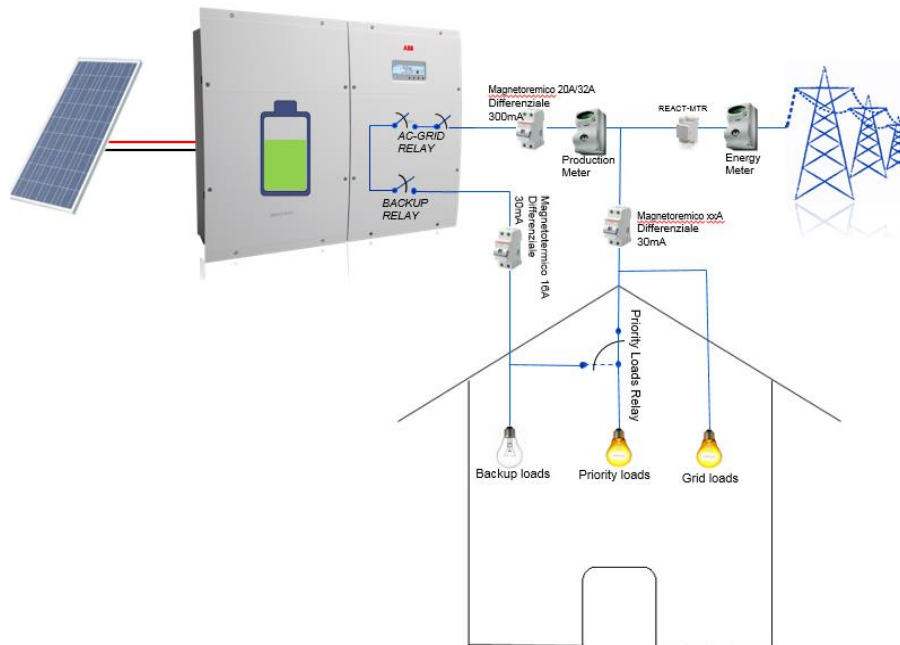

Schematic diagram of a household system with backup line

The backup output can support household loads (e.i. A refrigerator, a freezer, heat pumps, hoovers, etc.) and electronic devices that comply with the specifications shown in Chapter 4.

### 3. General recommendations

The backup output must be considered as a source of power completely independent on the electric grid of the local distributor, which provides dedicated loads or priority loads as defined in the previous section, so it must be sized and designed in a workmanlike manner in compliance with the applicable legislation in force in the place where the system is installed (see Chapter 4). All the utilities fed by the backup line will be supported as long as the energy from the photovoltaic field and the energy accumulated in the battery will be sufficient to meet the demand of connected users.

Furthermore, we point out that the backup function should not be considered as an emergency function, but rather as an uninterruptible power supply (**UPS**) system installed to provide constant power to the equipment connected, even in case of network malfunction. If, and only if, the automatic mode is set (see Chapter 5), the backup output can be activated in about two minutes after a network fault to provide power to the utilities connected.

**For safety reasons, it is mandatory** to appropriately identify the electric sockets connected to the backup line, since they could be powered even if there is no network connection. For this reason, all the sockets connected to the backup output should be marked with an identification tag, with indication, in the main switchboard, of the presence of an alternative source of power to the distributor's grid.

So, as for the systems where emergency/UPS systems are installed, the presence of any dangerous voltage in the circuit must be indicated to prevent risks in case of actions and operations on the electric system. We recommend using warning methods like the one shown in the figure:



**Prima di operare su questo circuito**

- Sezionare la linea di Backup
- Quindi verificare, la presenza di Tensione Pericolosa tra tutti i morsetti, compresa la terra di protezione

**Rischio di Ritorno di Tensione**

In the backup operating mode, the system automatically connects the neutral conductor of the earth line, this ensuring a correct operation of the dedicated differential protection.

### 4. Specifications

The backup output is a single-phase AC voltage supply made available by the inverter, which must be sized like any single-phase line. The following section provides the specifications of the output and indications on how to size the connected line.

The backup output is accessible through the AC-1 connector available on the REACT-UNO inverter by wiring the BACK-UP terminal block in the machine, which can be reached after disconnecting the machine (consult the manual for the procedure) by removing the front panel of the inverter, as shown in the figure:

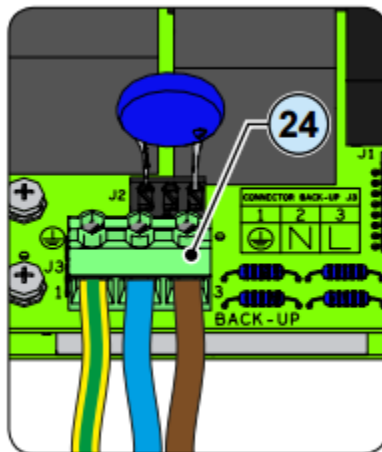
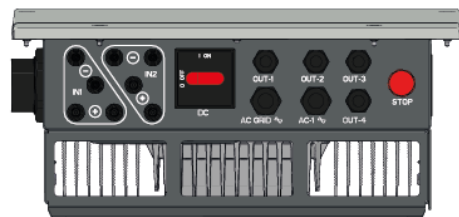
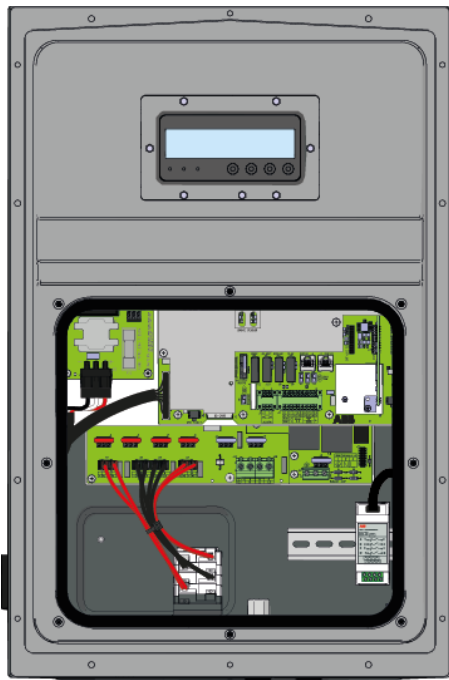

three connections are required to connect the backup output: Phase, Neutral and Earth, with a cable of a maximum size of 4 mm<sup>2</sup> (the connection of the earth wire is mandatory).

The electrical features of the backup output to be taken into account for the sizing of the line are indicated in the table below:

BACKUP OUTPUT – Technical Data	
Rated AC output Voltage (V <sub>acr</sub> )	230 V (1Ø)
Maximum output Current (I <sub>ac max</sub> )	13 A
Rated output Frequency (f <sub>r</sub> )	50 Hz
Maximum Apparent output Power (S <sub>acr</sub> )	3000 VA
Maximum output fault current	27 A rms (60ms)
Maximum AC overcurrent protection	16A

We recommend sizing the conductor by defining the section based on the length of the line in order to limit voltage dips at the load terminals, and therefore avoid any unwanted disconnection of the utilities connected to the backup source. In this regard, the following table should be considered as reference:

BACKUP OUTPUT – Sizing of the line conductor	
Conductor size (mm <sup>2</sup> )	Maximum length of conductor (m)
1.5	6
2.5	11
4	19

The values are determined in nominal power conditions by considering:  
- max 1% loss of power along the line  
- copper cable used with HEPR rubber insulation, laid in free air

The backup line must be protected by installing a device against maximum current and dispersion currents characterised by the features below:

BACKUP OUTPUT – Dedicated under load protection	
Type	Circuit breaker with differential magnetic-thermal protection
Voltage rating	230 Vac
Current rating	16 A
Magnetic protection charact.	B/C
Type of differential protection	A/AC
Differential sensitivity	30 mA
Number of poles	2

For differential protection, we suggest using the ABB DS201C16 model.

## 5. Operation modes

There are 6 modes that can be selected for the operation of the backup system. They can be set on the inverter's display through the backup menu or through the web server inside the inverter.

The user/designer will select the most appropriate operation mode for the intended use of the system in the house or, more generally, in the place where the system is installed.

These 6 operation modes are described below, with indication on how to enable and disable them for each input and output of the backup system.

The types of work include 4 manual modes, that need an external manual input to be activated, and 2 automatic modes, that are activated automatically depending on the state of external logics, such as a power failure or the state of a dedicated control.

In the description of the various operation modes, the term “power failure” means the absence of voltage at the output terminals of the inverter, a condition that can NOT coincide with the absence of voltage inside the house or in the system in general.

We specify that the inverter will never be simultaneously operating in Grid Connected mode and Backup mode, therefore the contactors connected to the AC GRID terminal block and to the BACKUP terminal block inside the machine will never be simultaneously closed. The principle is that the inverter will switch between three different states that exclude one another, as shown in the figure below:

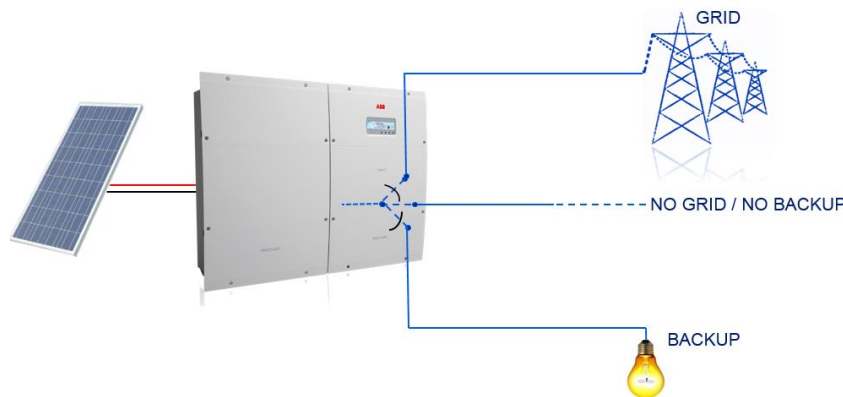

## 5.1 Selecting the mode: overview

Before describing each individual Mode, we will provide a summary table of all the conditions for the activation and operation of the system in connection with the mode selected in order to guide the user/designer in the selection of the most appropriate mode:

	<b>Power failure</b> <i>(at the output terminals of the inverter)</i>	<b>Manual start</b> <i>(press 'Enter' for 5 sec)</i>	<b>External logic signal</b>	<b>Black-out system</b>
<b>Manual 1</b>		√	√	
<b>Manual 2</b>		√		
<b>Manual 3</b>	√	√		√
<b>Manual 4</b>	√	√	√	√
<b>Auto 1</b>			√	
<b>Auto 2</b>	√			√
<b>None</b>				

The following section describes in detail each individual backup operation mode indicated in the table.

## 5.2 Operating conditions

### 1. Mode: Manual 1

In Manual Mode 1, the inverter may operate in the backup mode if and only if the following two conditions simultaneously exist:

1. *Control/signal* from external logic (to set the control, see section 5.4)
2. Manual start (press “Enter” on the display for at least 5 sec);

INPUT  
CONDITION

This mode may be used whenever condition 1 exists (previously established according to a preset control logic) and the user wants to activate backup operation, even in presence of the home network. The external control logic can be associated with the state of the network by closing a NO contact in case of malfunction or absence of power in certain sections of the system or in the entire dwelling. The activation signal may even be linked to a contact of the Load Manager Relay installed in the REACT system by using the time window setting of the relay (see the product's manual) or to any other external logic established by the user/designer during the design of the system.

In the event that the activation logic is not linked to a power failure, when Conditions 1 and 2 occur, the inverter will disconnect and switch to backup operation mode.

Two possible schemes that can be designed and that describe the operation of this mode are shown below:

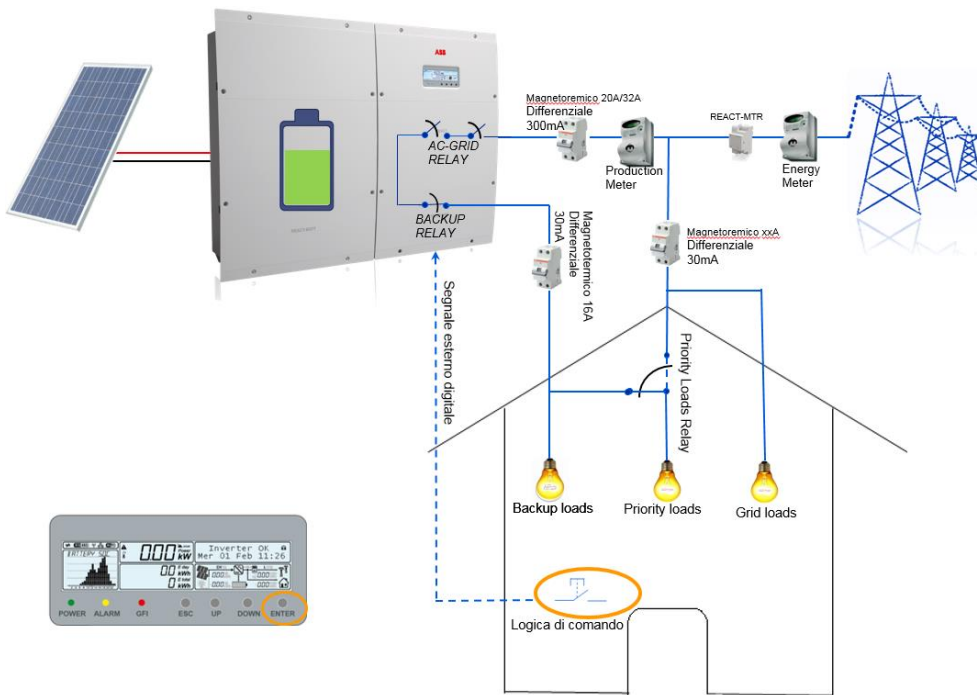

**Manual1: Backup operation in the presence of power, through manual activation and signal from external logic**

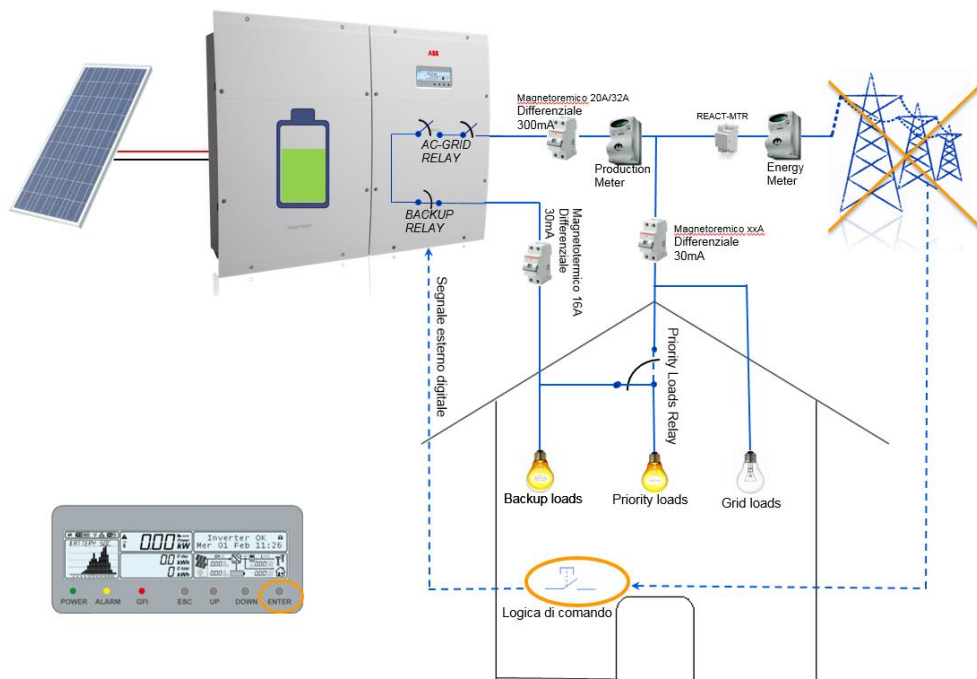

**Manual1: External logic linked to power failure, backup operation through manual activation**

At least one of the following STOP conditions must be met for the backup mode output:

1. Press 'ESC' on the display for at least 5 seconds
2. External control signal cancelled (open contact)

Once it has left the backup mode, the inverter will check the conditions of the network and, after ensuring that Voltage and Frequency parameters are correct, it will start the reconnection sequence.



## 2. Mode: Manual 2

In the Manual 2 mode, the inverter may operate in backup mode if the following condition exists:

INPUT  
CONDITION

1. Manual activation (press “Enter” on the display for at least 5 sec).

If it is set, this mode can be activated whenever the user wants to power only the loads connected to the backup line, even in the presence of the home network. In this case, the inverter will disconnect from the network and switch to backup operation.

A possible scheme that can be designed and that describes the operation of this mode is shown below:

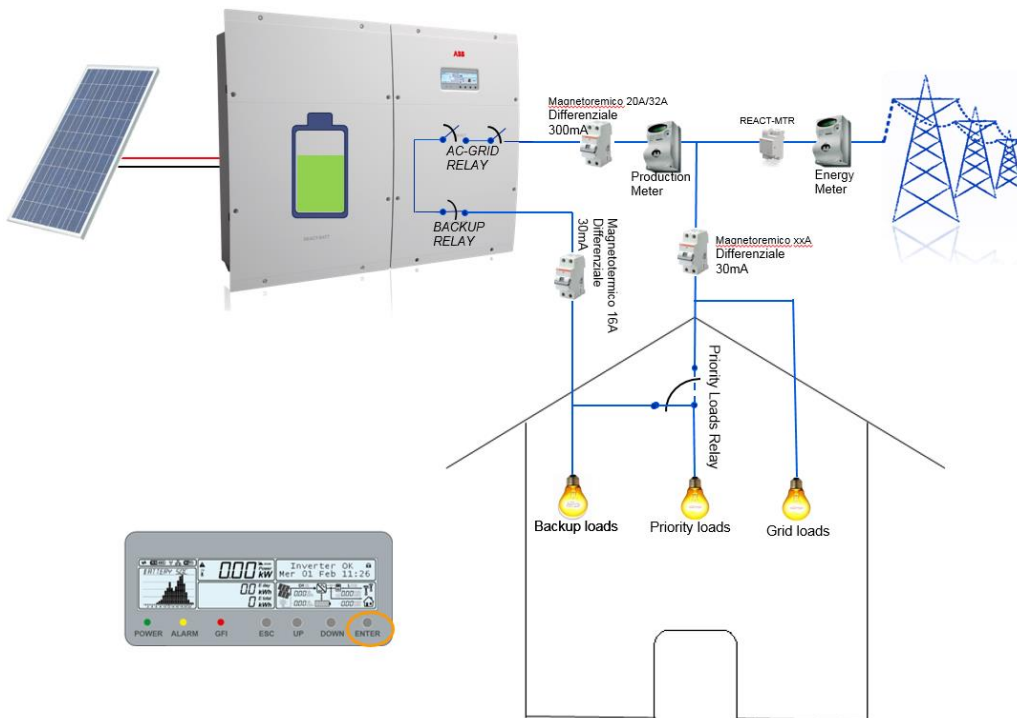

Manual 2: Backup operation in the presence of power, through manual activation

The following STOP conditions must be met for the backup mode output:

INPUT  
CONDITION

1. Press ‘ESC’ on the display for at least 5 seconds

Once it has left the backup mode, the inverter will check the conditions of the public mains network and, after ensuring that Voltage and Frequency parameters are correct, it will start the reconnection sequence.

## 3. Mode: Manual 3

In Manual Mode 3, the inverter may operate in the backup mode if and only if the following two conditions simultaneously exist:

INPUT  
CONDITION

1. Power failure at the output terminals of the inverter (Voltage and Frequency values outside the Mains OK range, established according to local standards).
2. Manual activation (press “Enter” on the display for at least 5 sec).

If this mode has been set, the inverter will switch to backup operation if and only if the system is in power failure conditions (absence of voltage at the inverter's output terminals) and the user decides to feed the loads connected to the backup line.

Two possible schemes that can be designed and that describe the operation of this mode are shown below:

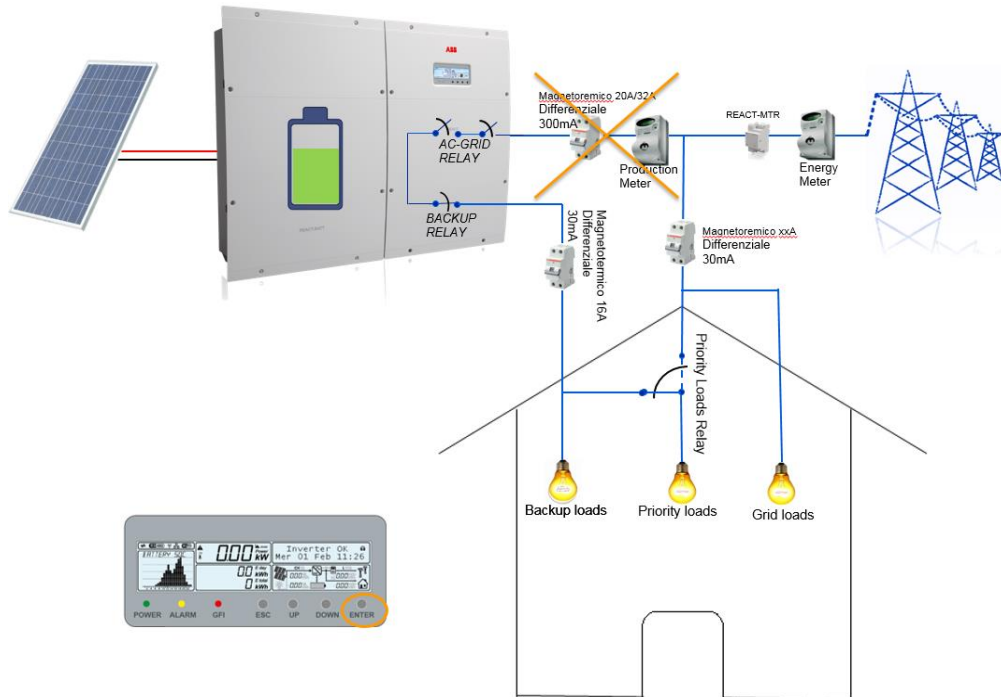

**Manual 3: Power failure due to activation of the protection device at the inverter output and backup operation through manual activation**

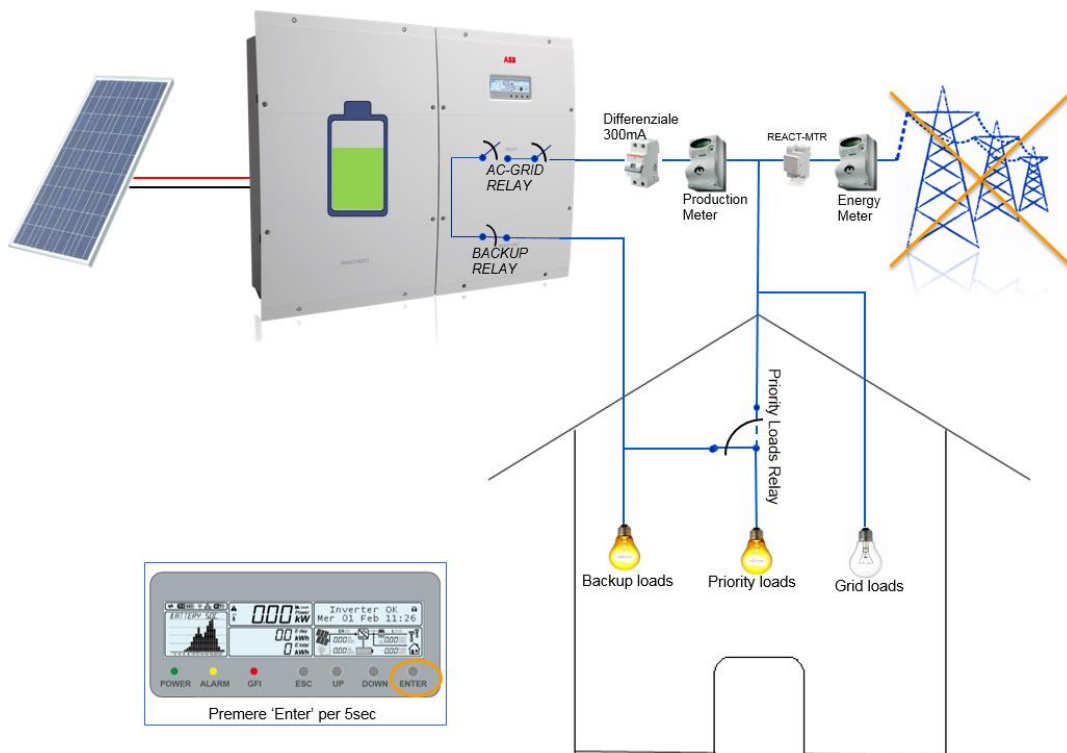

**Manual 3: System black out and backup operation through manual activation**

At least one of the following STOP conditions must be met for the backup mode output:

INPUT  
CONDITION

1. Press 'ESC' on the display for at least 5 seconds
2. Return of mains voltage (Voltage OK at the inverter's output terminals)

Once it has left the backup mode, the inverter will check the conditions of the public mains network and, after ensuring that Voltage and Frequency parameters are correct, it will start the reconnection sequence.

#### 4. Mode: Manual 4

In Manual Mode 4, the inverter may operate in the backup mode if and only if the following three conditions simultaneously exist:

INPUT  
CONDITION

1. Power failure at the output terminals of the inverter (Voltage and Frequency values outside the Mains OK range, established according to local standards).
2. Control/signal from external logic (to set the control, see section 5.4);
3. Manual user activation (press "Enter" on the display for at least 5 sec);

If this mode has been set, the inverter will switch to backup operation if and only if the system is in power failure conditions (absence of voltage at the inverter's output terminals), the activation signal sent by the external logic is present, and the user decides to activate the system's backup operation.

A possible scheme that can be designed and that describes the operation of this mode is shown below:

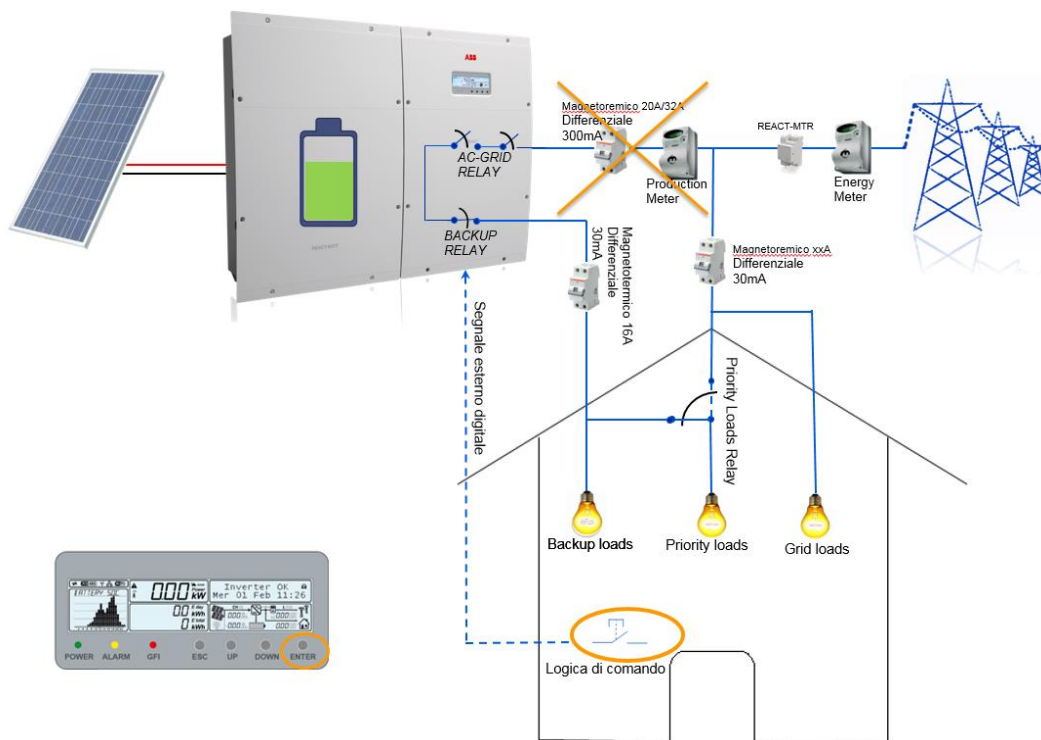

**Manual 4: Backup operation after activation of the 300mA differential switch, presence of external control and manual activation**

At least one of the following STOP conditions must be met for the backup mode output:

INPUT  
CONDITION

1. Press 'ESC' on the display for at least 5 seconds.
2. External control signal cancelled (open contact)
3. Return of mains voltage (Voltage OK at the inverter's output terminals)

Once it has left the backup mode, the inverter will check the conditions of the public mains network and, after ensuring that Voltage and Frequency parameters are correct, it will start the reconnection sequence to the same network.

### 5. Mode: Auto 1

In the Automatic 1 mode, the inverter may operate in backup if and only if the indicated condition exists:

INPUT  
CONDITION

1. *Control/signal* from external logic (to set the control, see section 5.4)

This mode may be used whenever the indicated condition exists (previously established according to a preset control logic), even in presence of the home network. The external control logic can be associated with the state of the network by closing a NO contact in case of malfunction or absence of power in certain sections of the system or in the entire dwelling. The activation signal may even be linked to a contact of the Load Manager Relay installed in the REACT system by using the time window setting of the relay (see the product's manual) or to any other external logic established by the user/designer during the design of the system capable of automating the activation of the backup operation.

In the event that the activation logic is not linked to a power failure, when Condition 1 occurs, the inverter will disconnect from the network and switch to backup operation mode.

A possible scheme that can be designed and that describes the operation of this mode is shown below:

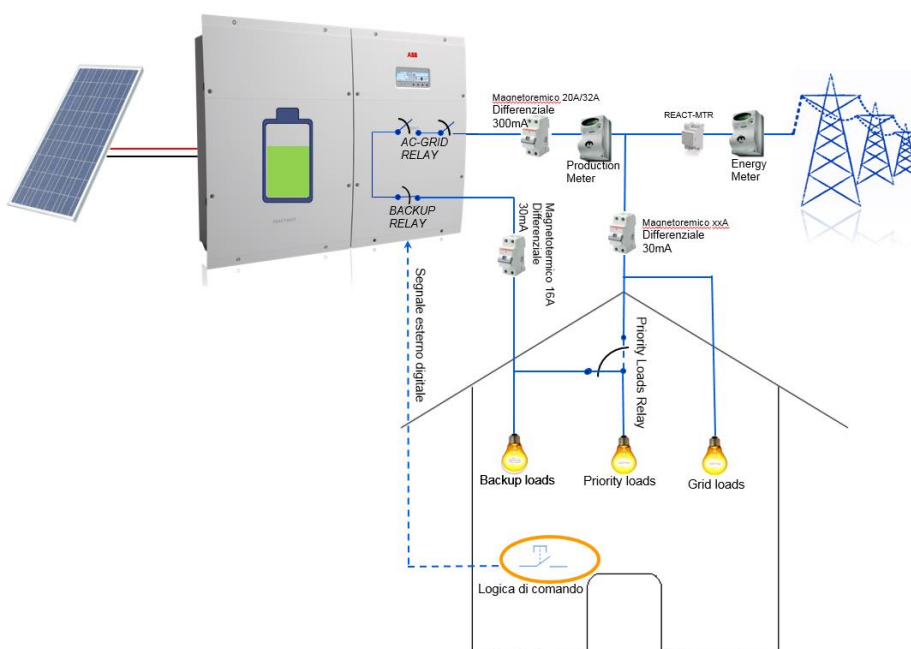

Auto 1: Backup operation to send external control from automatic logic

The following STOP conditions must be met for the backup mode output:

INPUT  
CONDITION

1. External control signal cancelled (open contact)

Once it has left the backup mode, the inverter will check the conditions of the public mains network and, after ensuring that Voltage and Frequency parameters are correct, it will start the reconnection sequence.

## 6. Mode: Auto 2

In the Automatic 2 mode, the inverter may operate in backup if and only if the following condition exists:

1. Power failure at the output terminals of the inverter (Voltage and Frequency values outside the Mains OK range, established according to local standards).

If Mode 2 is set, the inverter will enter in backup mode in case of malfunction or power failure at general level (system black-out) or in case of malfunction at inverter level (e.g. activation of protection devices at inverter output).

Three possible schemes that can be designed and that describe the operation of this mode are shown below:

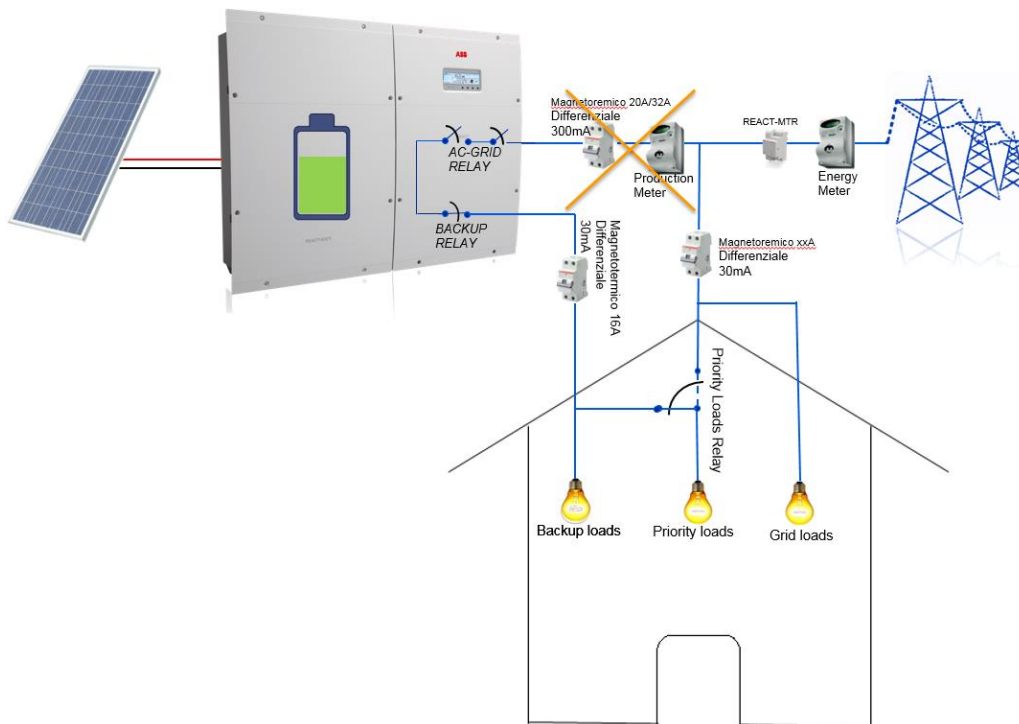

**Auto2: Backup operation due to activation of protection devices installed at inverter output (power failure at inverter output terminals)**

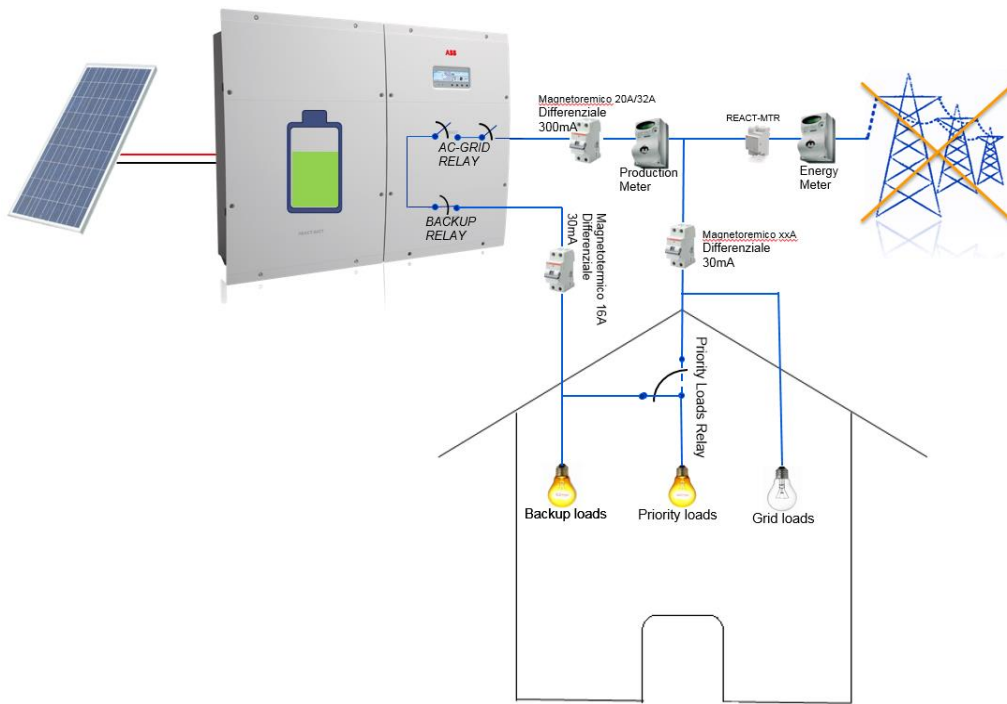

**Auto2: Backup operation after general system black-out**

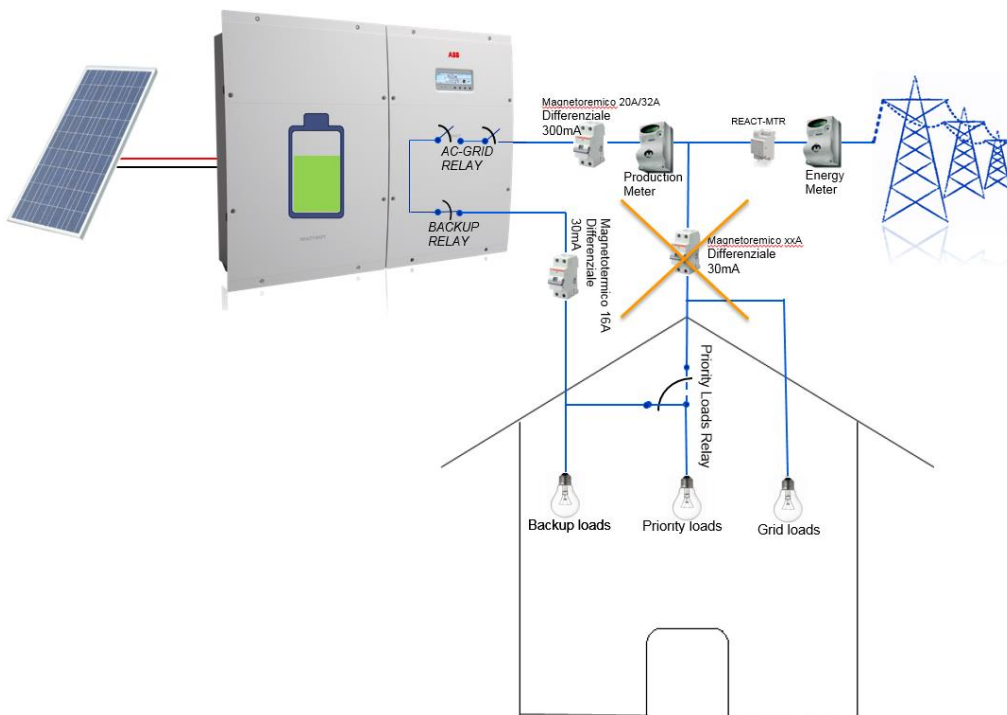

**Auto2: activation of residential protection system, connected inverter, utilities OFF, NO backup**

The following STOP conditions must be met for the backup mode output:

1. Return of power to inverter terminals (Voltage and Frequency values within the Mains OK range, established according to local standards).

Once it has left the backup mode, the inverter will check the conditions of the public mains network and, after ensuring that Voltage and Frequency parameters are correct, it will start the reconnection sequence.

INPUT  
CONDITION

### 5.3 Mode configuration

The 6 modes described in section 5.2 must be set during the commissioning of the system (see product’s manual) or later by using the display of the inverter or a web server. Preset factory values are “None”, which means that there is no backup operation by default.

Before setting backup operation modes, the user must consider another parameter to be set, which is described below:

**Set SOC Th. -** : Battery charge percentage value indicating the percentage preserved for backup operation (default: 4%). During normal “Grid connected” operation, the battery will never be discharged beyond the value set. Therefore, if we assume a 2 kWh battery charge and we set the parameter at 50% in the normal Grid Connected operation, the inverter, if necessary, will draw up to a maximum of 1 kWh from the battery and, if the system switches to backup operation, it may use all the available accumulated energy, i.e. From 1 kWh to a maximum of 2 kWh.

If users are not planning to use backup operation often, we recommend keeping this parameter set at the minimum value or disabled (‘None’).

This value can be set from the display or web server following the two procedures indicated below:

- **Display setting**

To set the desired values through the display, use the “up” and “down” keys to browse the menus and confirm by pressing “Enter”, as shown in the flow diagram below (*further details on the use of the display are provided in the product's manual*):

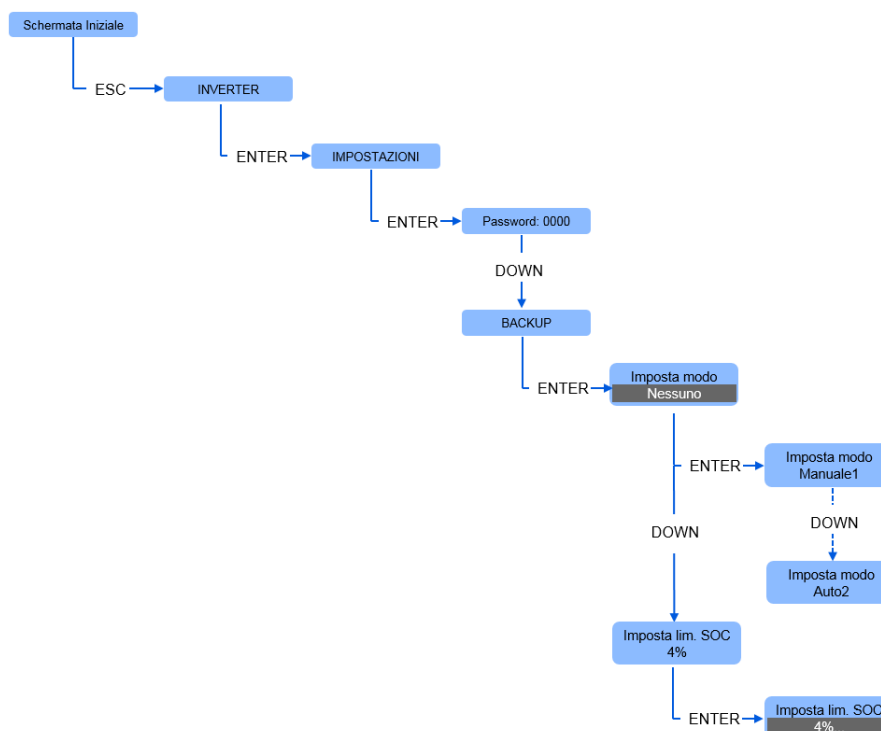

- **Web server setting**

To set the desired values from the web server, first of all the REACT system must be connected with a PC/Tablet/Smartphone by means of a Wi-Fi connection (*consult the product's manual for indications on how to connect to the web server or for further information*), then the desired parameters can be set as shown in the sequence below:

1. From the main page or “Dashboard”, click on “REACT Parameters” in the Settings menu:

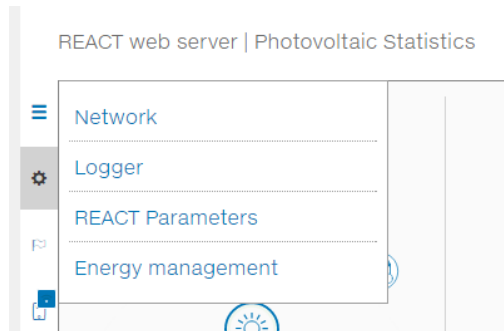

2. Select “Backup output” as the desired mode in the “Backup type” drop-down menu and the residual charge state from the “Residual SOC” drop-down menu (default value: 4%), then press the “Save” button to enable the settings:

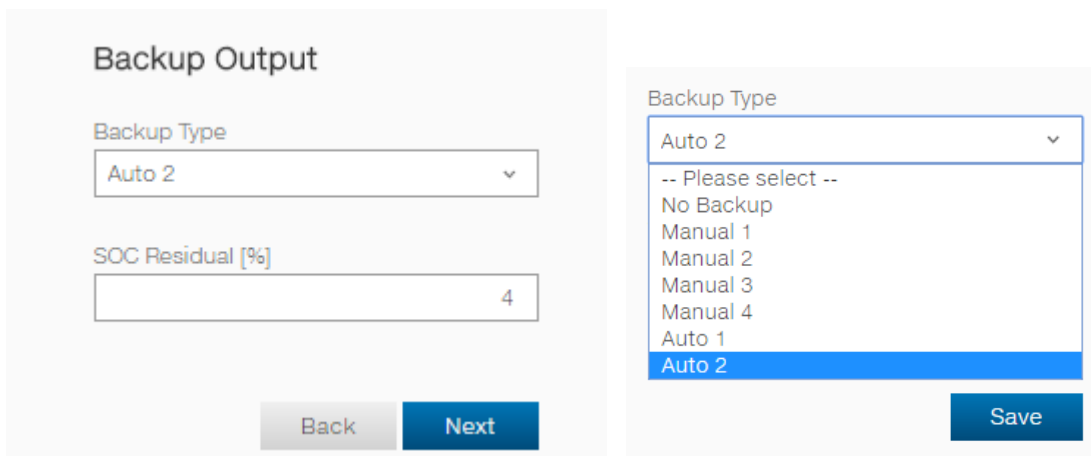

## 5.4 Control/signal from external logic

To use the external digital control required in the *Auto1*, *Manual 1* and *Manual 3* modes, the user must connect terminals 1 and 3 from the terminal block J3 as shown below:  
(*Before performing any action on the terminal block, make sure that the machine is disconnected by pressing the STOP push-button and selecting the DC and AC section.*)



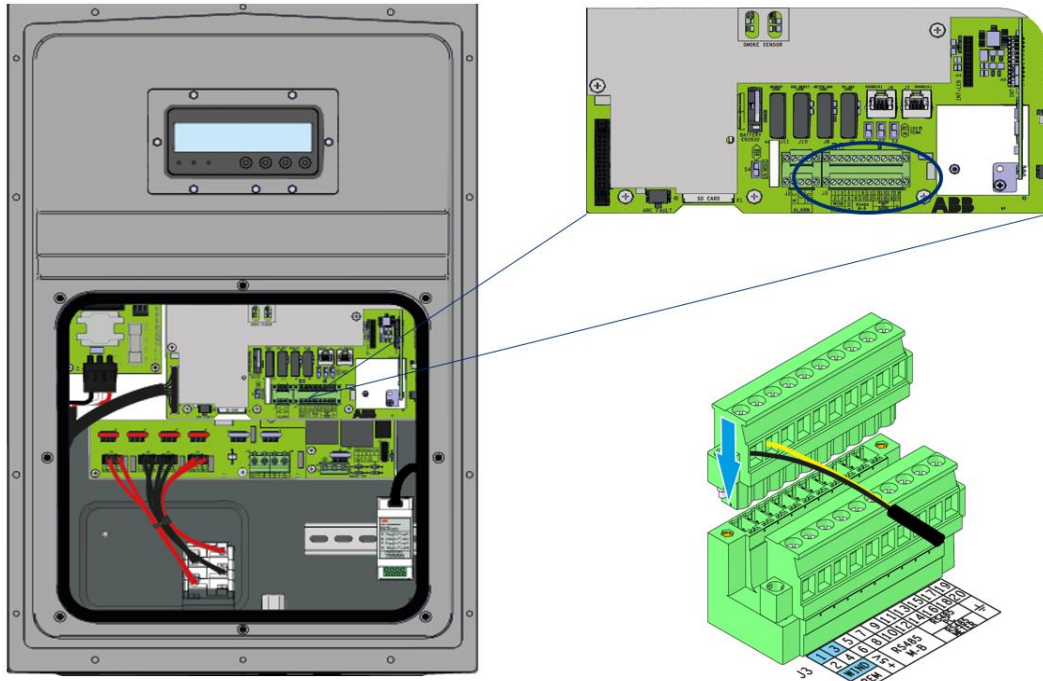

To enable the indicated modes, a short circuit must be created across terminals 1 and 3. Since this is a digital input, there are no instructions on the size of the cable to be used (just comply with the recommended sizing for the passage of cables on the cable glands and terminal block).

## 6. Priority loads relay

For a correct use of the backup function with Priority Loads, a configuration IS REQUIRED that can maintain a separation between the backup line / distributor grid connection in every operating condition. We recommend using two ABB *ESB40-22-230AC/DC* model contactors with the following simplified electrical diagram:

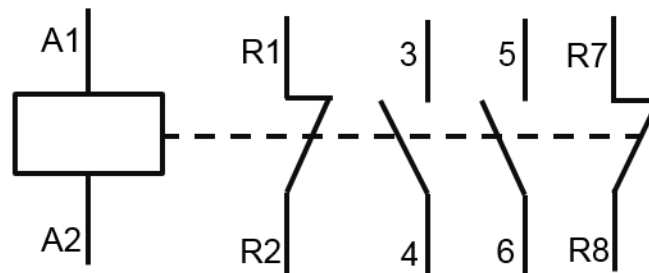

As shown in the diagram, contacts between terminals R1/R2 and R7/R8 are normally closed (NC), while contacts between terminals 3/4 and 5/6 are normally open (NO), and a drive coil is provided at terminals A1/A2.

By interlocking two relays of the indicated model, the backup line can be kept separated from the mains in every operating condition, as shown in the electric diagram provided in the two images below.

If modes *Manual 2*, *Manual 3* and *Auto 2* are set, for which there is NO need for an external digital signal, this is a possible connection diagram:

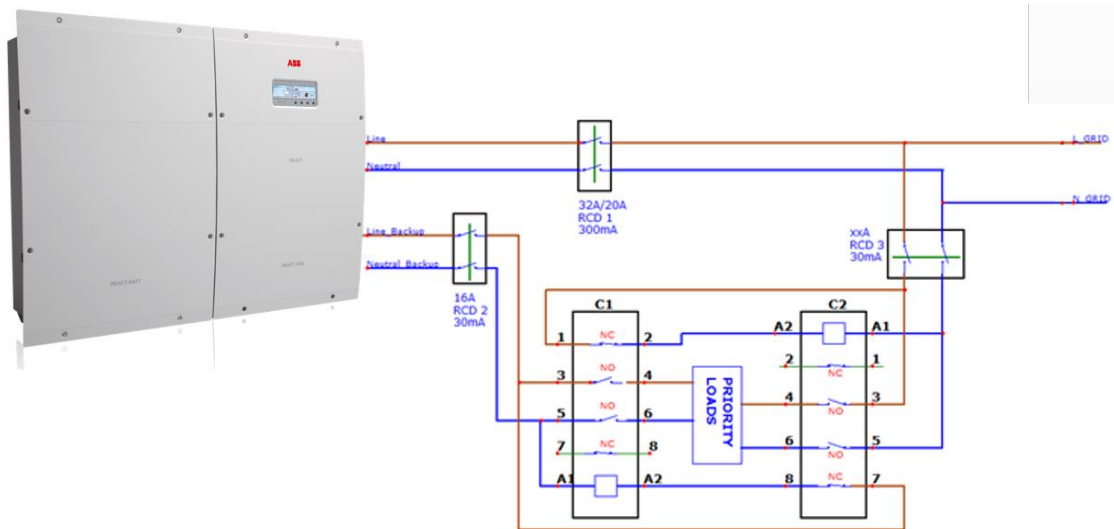

Relay connection diagram with Manual 2, Manual 3 and Auto 2 modes

If modes *Manual 1*, *Manual 4* and *Auto 1* are set, for which an external digital signal is needed, this is a possible connection diagram:

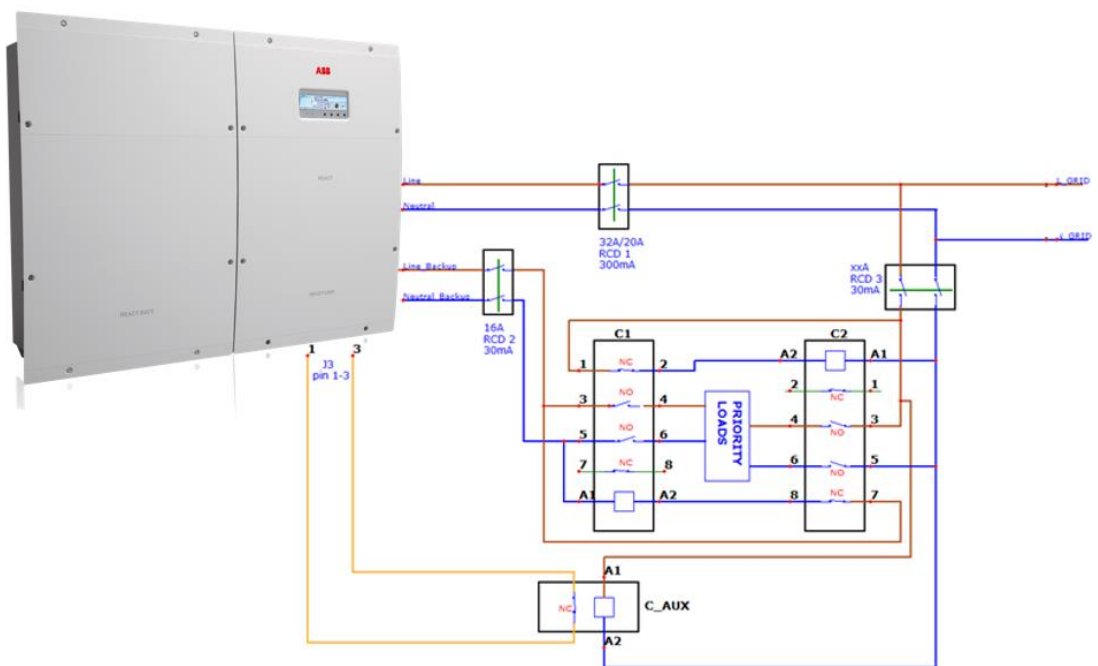

Relay connection diagram with Manual 1, Manual 4 and Auto 1 modes

In order to ensure the separation of the two power systems (backup and mains), the connections between the terminals of the contactors must be met as shown in the figure, where C1 and C2 are the two contactors of the same *ESB40-22-230AC/DC* model.

**Note:** With the configurations shown, the priority loads could be powered from the mains even in case of backup system operation, depending on which of the two contactors (C1,C2) is activated first.



Each operation on the *REACT-3.6/4.6-TL* system shown in this document must be performed in compliance with the safety measures recommended by the local

For more information contact your local ABB representative or visit:

[www.abb.com/solarinverters](http://www.abb.com/solarinverters)

© Copyright 2014 ABB. All rights reserved.  
Specifications subject to change without notice.