

ABB solar inverters

Product manual
ULTRA 6/8 DC input
(700 to 1400 kW)





IMPORTANT SAFETY INSTRUCTIONS

This manual contains important safety instructions that must be followed during installation and maintenance of the equipment.



SAVE THESE INSTRUCTIONS!

This manual must be considered as an integral part of the equipment, and must be available at all times to everyone who interacts with the equipment.

The manual must always accompany the equipment, even when it is transferred to another user.



Operators are required to read this manual and scrupulously follow the indications reported in it, since ABB cannot be held responsible for damages caused to people and/or things, or the equipment, if the warranty conditions are not observed.

Product Manual

ULTRA-6/8 DC

1 - Introduction and general information



2 - Characteristics



3 - Safety and accident prevention



4 - Lifting and transport



5 - Installation



6 - Instruments



7 - Operation



8 - Maintenance



Warranty and Supply Conditions

The warranty conditions are described in a special certificate supplied with the equipment. Furthermore, the warranty conditions are considered to be valid if the customer adheres to the indications in this manual; any conditions deviating from those described herein must be expressly agreed in the purchase order.

The equipment complies with the pertinent legislation currently in force in the country of installation and it has issued the corresponding declaration of conformity.

Not included in the supply

ABB accepts no liability for failure to comply with the instructions for correct installation and will not be held responsible for systems upstream or downstream the equipment it has supplied. It is absolutely forbidden to modify the equipment. Any modification, manipulation, or alteration not expressly agreed with the manufacturer, concerning either hardware or software, shall result in the immediate cancellation of the warranty.

The Customer is fully liable for any modifications made to the system.



Given the countless array of system configurations and installation environments possible, it is essential to check the following: sufficient space suitable for housing the equipment; airborne noise produced depending on the environment; potential flammability hazards.

ABB will NOT be held liable for defects or malfunctions arising from: improper use of the equipment; deterioration resulting from transportation or particular environmental conditions; performing maintenance incorrectly or not at all; tampering or unsafe repairs; use or installation by unqualified persons.

ABB will NOT be held responsible for the disposal of: displays, cables, batteries, accumulators etc. The Customer shall therefore arrange for the disposal of substances potentially harmful to the environment in accordance with the legislation in force in the country of installation.

Contents



Introduction and general information	5
Warranty and Supply Conditions	5
Not included in the supply.....	5
Contents	6
Reference Number Index	10
Graphical representation of references	11
General view	11
DC input compartment (6-input version).....	12
DC input compartment (8-input version).....	13
Conversion compartment.....	14
Conversion module and cooling system.....	15
AC and user interface compartment.....	16
The document and who it is for	17
Purpose and structure of the document	17
List of annexes	17
Staff characteristics.....	17
Symbols and signs	18
Field of use, general conditions	19
Intended or allowed use.....	19
Limits in field of use	19
Improper or prohibited use	19
Characteristics	21
General conditions	21
Models and range of equipment	22
Conversion module configurations	22
Grounding configuration of the DC inputs	24
Identification of the equipment and manufacturer	25
Safety labels present on the inverter	26
Characteristics and technical data	27
Tightening torques	29
Characteristics of the LV-MV/LV-LV transformer for -TL models	30
Multi-inverter installation on a single transformer	30
Overall dimensions of ULTRA-700.0-TL.....	31
Overall dimensions of ULTRA-1050.0-TL.....	32
Overall dimensions of ULTRA-1400.0-TL.....	33
Efficiency curves	34
Power derating	34
Power derating due to environmental conditions	35
Power reduction due to the input voltage	36
Power reduction as a function of the grid voltage	36
Characteristics of a photovoltaic generator	37
Strings and Arrays.....	37



Description of the equipment	38
Main characteristics	38
Operating diagram	39
Mutual connection of multiple inverters	39
Notes on the system sizing.....	39
Topographic diagram of the equipment	40
Equipment features and components	41
Protective awning.....	43
Safety devices	44
Anti-Islanding	44
Protection fuses	44
Overvoltage surge arresters	45
Monitoring the components	45
Other protective devices	45
Safety and accident prevention	47
Safety instructions and general information	47
Hazardous areas and operations	48
Environmental conditions and risks	48
Signs and Labels	48
Thermal hazard	49
Clothing and protective devices for staff.....	49
Residual risks	50
Table: residual risks.....	50
Lifting and transport	51
General conditions	51
Transport and handling	51
Lifting.....	51
Unpacking and checking	51
Mode of lifting.....	52
List of components supplied	55
Installation	57
General conditions	57
Environmental checks.....	58
Installations above 2000 metres	58
Installation position.....	59
Preparation and requirements of the base	60
ULTRA-700 base dimensions	62
ULTRA-1050 base dimensions	63
ULTRA-1400 base dimensions	64
Location and mounting on the base	65
Operations to be performed after mounting	66
Operations preparatory to electrical connections	66
Operations preparatory to PV generator connection	67
Checking the correct polarity of the strings	67
Checking of leakage to ground of the photovoltaic generator.....	67
Connections to the DC input compartment (6/8-input versions)	68
Opening and accessing the DC connections zone	68
Feeding the DC cables inside the inverter.....	69
Preparation of the DC cables.....	69
Installation of DC cable glands	70



Installation of cables on the DC input bar.....	72
Final operations.....	73
Connections to the AC and user interface compartment.....	74
Opening and accessing the AC connections zone.....	74
Feeding the AC cables inside the inverter.....	75
Preparation of the AC output, ground and auxiliary voltage cables	75
Installation of AC cable glands.....	76
Connections of the ground conductors.....	78
Connection of the AC auxiliary line.....	78
Connection of the output cables to the AC output bars.....	79
Final operations.....	80
Connections to the communication and control board.....	81
Communication and control board.....	82
Auxiliary contact connection (AUX CONT).....	83
RS485 PC serial connection.....	84
RS485 SC (PVI-STRINGCOMB) Serial Connection.....	85
RS485 MON (monitoring system) Serial Connection.....	86
Connections to the power monitoring unit (PMU).....	87
Instruments.....	89
General conditions	89
Display and buttons	90
Description of the display.....	90
Description of warning lights and switches on the front door	90
Display status LED indication	91
Auxiliary panel	92
Description of the panel	92
Control relay of phases and sequence.....	92
Power monitoring unit (PVI-PMU)	93
“Aurora Central CVI Ultra” advanced configuration software.....	94
Operation.....	95
General conditions	95
Monitoring and data transmission	96
User interface mode.....	96
Types of data available	96
Commissioning.....	97
Preliminary checks with no auxiliary voltage	97
Preliminary checks for the inverter configuration and monitoring	97
Preliminary checks for the external heat exchangers	98
Preliminary checks for the DC, AC output and auxiliary AC voltages	98
Preliminary checks for the emergency system.....	99
Commissioning procedure.....	100
Using the display and menu structure.....	103
Statistics Menu	104
Total.....	104
Partial	104
Today.....	104
Last 7 days.....	105
Last 30 days.....	105

Last 365 days	105
User period.....	105
Settings Menu	106
Date/Time.....	106
Currency.....	106
Display.....	106
Language	107
Configuration Wizard	107
Service	109
Info Menu.....	112
Rack Monitor Menu	113
Solar Field Menu.....	114
Status lights (WARNING LIGHTS) behaviour	115
Inverter switch-off.....	116
Software switch-off.....	116
Hardware switch-off	116
Maintenance.....	119
General conditions	119
Routine maintenance	120
Troubleshooting	122
Alarm messages	122
Storage and dismantling	127
Storage of the equipment or prolonged stop	127
Dismantling, decommissioning and disposal.....	127
Further information	128
Contact us	129



Reference Number Index

- i**
- 01 protective awning
 - 02 eyebolts
 - 03 safety switch
 - 04 support feet
 - 05 forklift slots
 - 06 front brackets
 - 07 rear brackets
 - 09 DC input compartment
 - 10 conversion compartment
 - 11 AC and user interface compartment
 - 12 crank handle
 - 13 casing

 - 21 latches
 - 22 DC input protection fuses
 - 23 DC cable glands
 - 24 DC input bars
 - 25 DC fuses cover plate
 - 26 DC bus bars cover plate

 - 30 external heat exchanger
 - 31 external heat exchanger fans
 - 32 pressure gauge
 - 33 coolant temperature display
 - 34 liquid cooling system manifolds
 - 35 internal heat exchanger
 - 36 top-up joint
 - 37 cold water joint
 - 38 hot water joint

 - 41 AC contactors
 - 42 front recirculation fan
 - 43 conversion module
 - 44 control logic module
 - 45 power supply module
 - 46 capacitor module
 - 47 DC disconnect switch
 - 48 DC overvoltage surge arresters
 - 49 quick connection assembly
 - 50 rear recirculation fans
 - 51 common board
 - 52 AC protection test board
 - 53 ground fault control board
 - 54 ground fault fuse
 - 55 ground fault relay
 - 56 AC zone cover plate
 - 57 conversion module cover plate
 - 58 DC zone cover plate
 - 59 conversion module locking screw
 - 60 communication and control board cover
 - 61 EMI filters
 - 62 AC output protection fuses
 - 63 auxiliary panel
 - 64 communication and control board
 - 65 display
 - 66 red warning light
 - 67 yellow warning light
 - 68 green warning light
 - 69 emergency button
 - 70 key switch
 - 71 AC disconnect switch
 - 72 AC overvoltage surge arresters
 - 73 AC output bars
 - 74 auxiliary overvoltage surge arresters
 - 75 auxiliary connector
 - 76 ground bar
 - 77 signal conduit
 - 78 AC cable glands
 - 79 AC fuses cover plate
 - 80 AC bars cover plate
 - 81 AC door
 - 82 display door

Graphical representation of references

General view

The ULTRA inverter is designed for external use and is normally supported by a base (see further details in the manual) that offers stability and allows easy routing of the input/output cables underneath the inverter.

The main sections composing the ULTRA inverter are:

- DC input compartment 09.
- Conversion compartment 10 and corresponding cooling system
- AC and user interface compartment 11

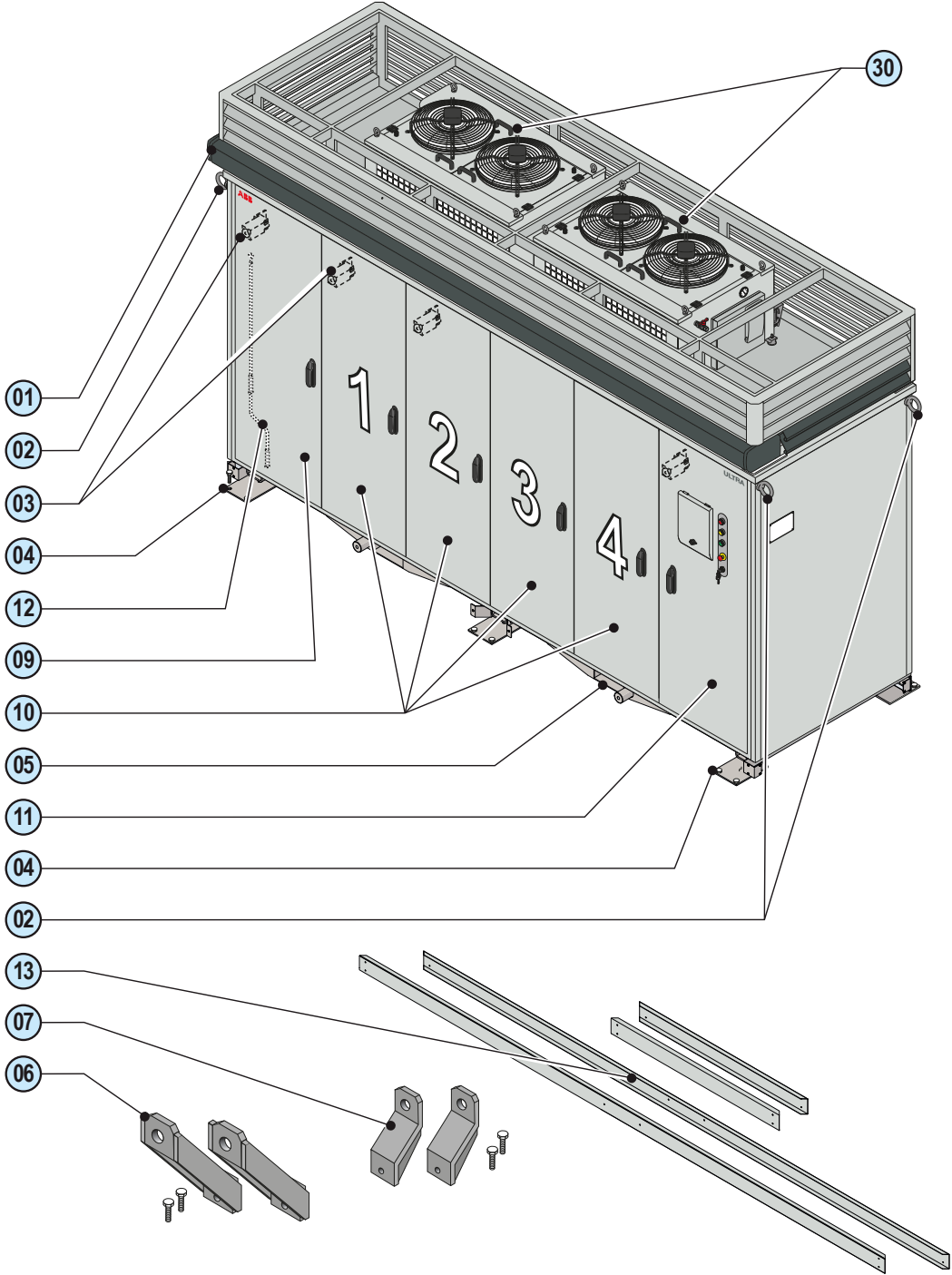

DC input compartment (6-input version)

This section of the inverter contains the DC connections and the housings for the input protection fuses (22).

The cables coming from the photovoltaic generator must be fed through the DC cable glands (23) to ensure IP65 protection rating and subsequently connected to the DC input bars (24).

The DC photovoltaic generator voltage is fed to the input of the conversion module (43) housed in the conversion compartment (10).

The desired number of available connections per conversion module (43) must be specified when the inverter is ordered:

- 6-input version (6 positive + 6 negative cable head connections)
- 8-input version (8 positive + 8 negative cable head connections).

The number of DC input bars (24) and fuse groups varies according to the number of conversion modules (43) inside the ULTRA inverter. The correspondence between input bar / fuse group and conversion module is marked in this manual and on special labels affixed inside the DC input compartment.

The figure on the side shows the correspondence between inputs and the corresponding fuses for each conversion module.

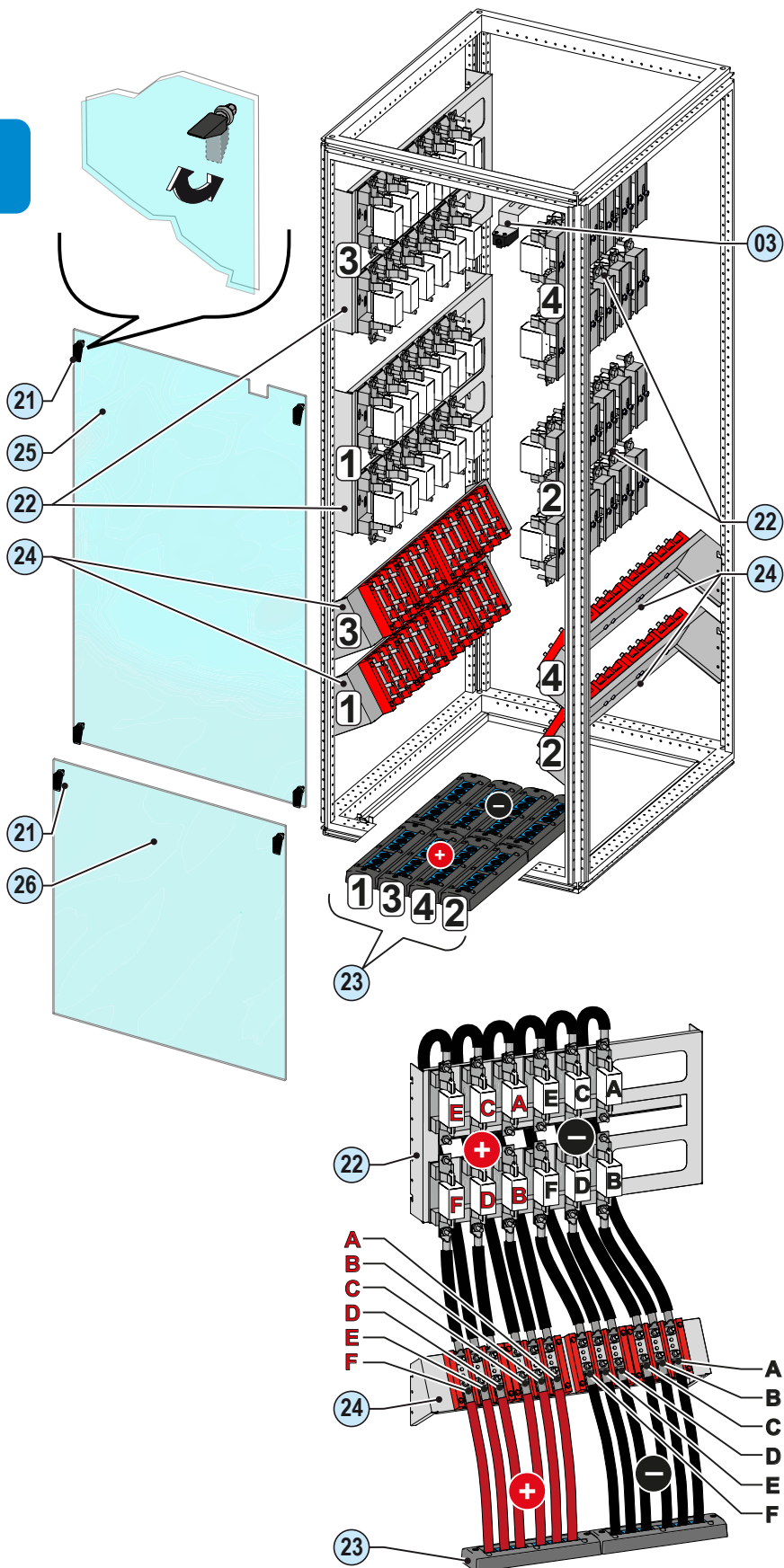

Dc input compartment (8-input version)

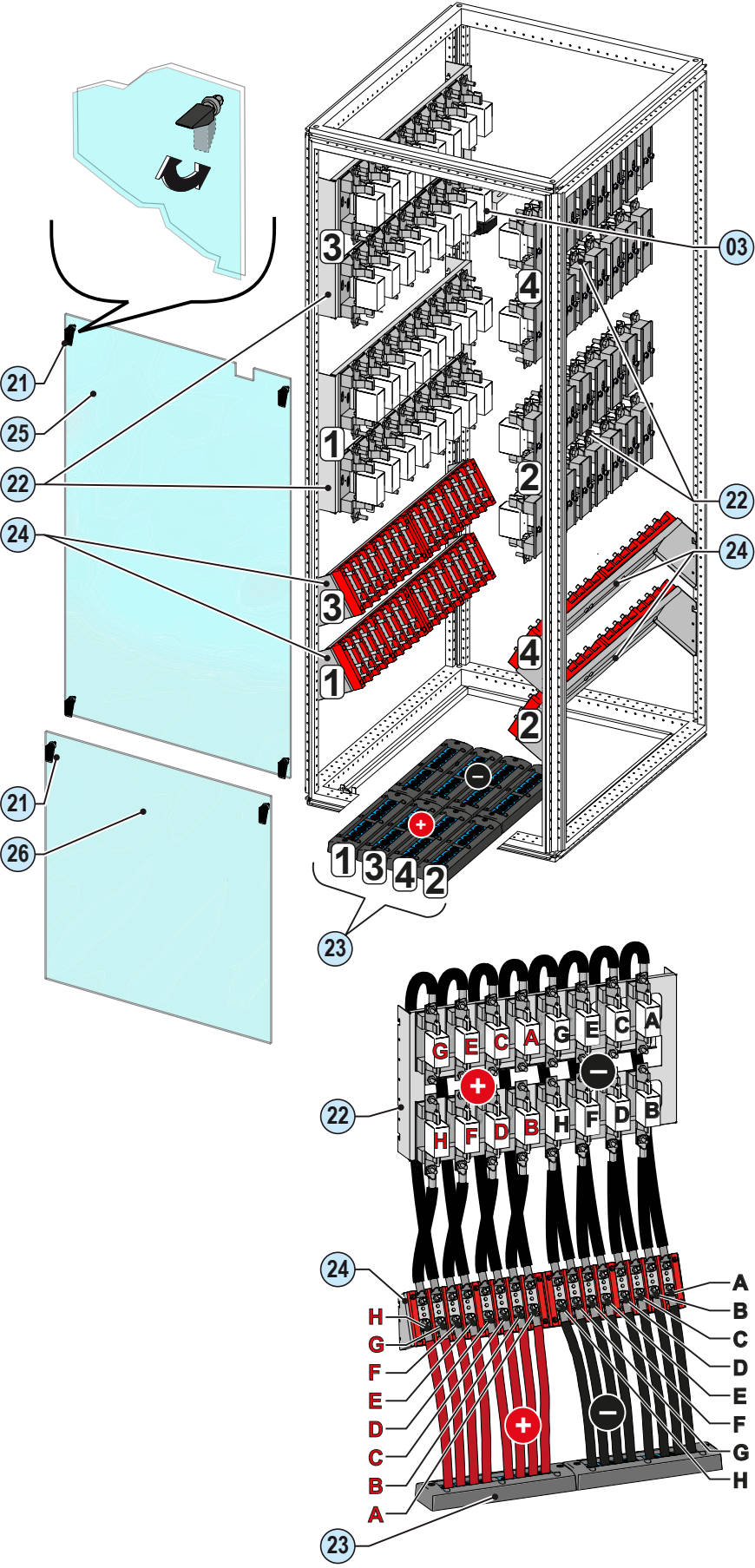

All aspects taken into consideration for the 6-input version apply to this DC input compartment 09 too.

The only differences are the number of available connections on each individual DC input bar 24 and the corresponding number of input protection fuses 22



The figure on the side shows the correspondence between inputs and the corresponding fuses for each conversion module.

Conversion compartment

The conversion compartment is the heart of the ULTRA inverter, as it contains the conversion module (43) responsible for the conversion of direct DC current (input) into alternating AC current (output).

The number of conversion compartments varies according to the output power of the inverter (2 for ULTRA-700.0-TL; 3 for ULTRA-1050.0-TL; 4 for ULTRA-1400.0-TL) and the compartments follow a numbering from 1 to 4 (left to right).

Each conversion compartment (10) is connected to the corresponding DC input bar that transmits the voltage from the photovoltaic generator through the DC disconnect switch (47); if the DC disconnect switch is closed, the input voltage is fed to the conversion module, (43) which converts it into AC voltage. The AC voltage is then fed to the AC and user interface compartment (11) through the corresponding AC contactors (41) and filters.

The compartment is cooled by a dedicated liquid cooling system and by internal air recirculation fans.

The figure on the side shows two coupled conversion modules (10).

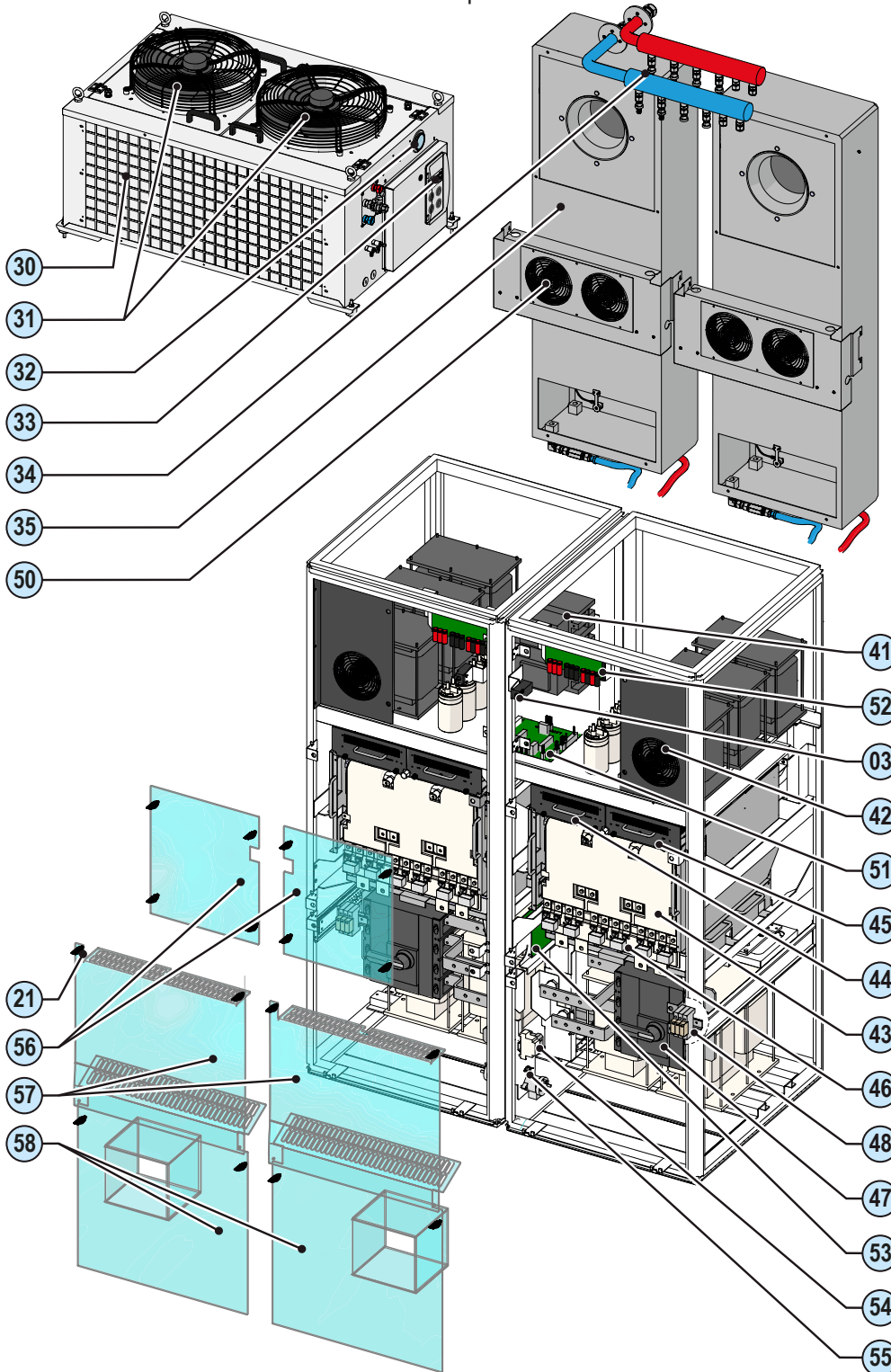

Conversion module and cooling system

The cooling system is powered by the auxiliary voltage and is mainly composed of:

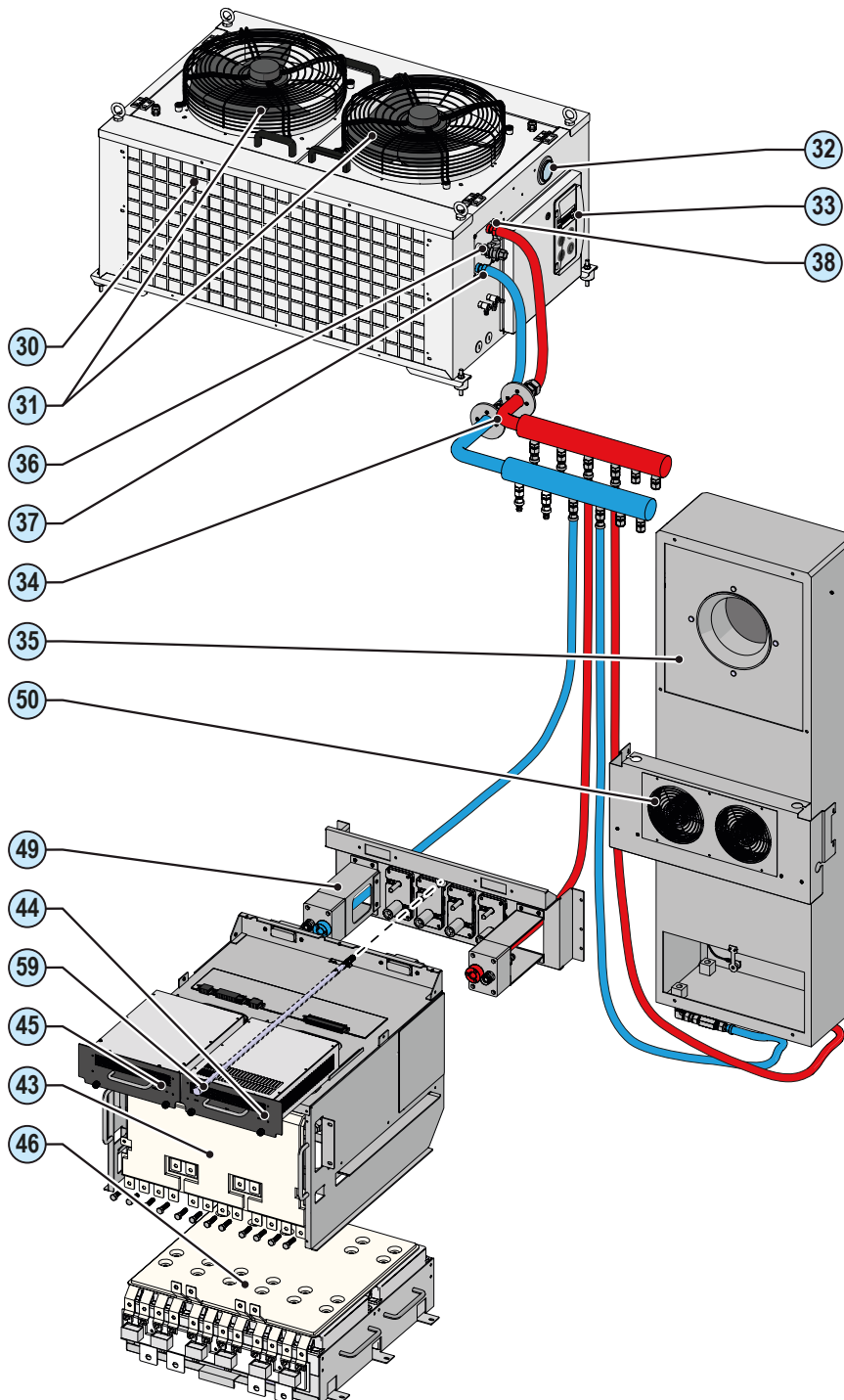

- Cold plate. Placed inside the conversion module (43), it dissipates the heat generated by the active components during their operation and it transfers it to the liquid coolant in the hydraulic cooling circuit.

- Internal heat exchanger (35). Placed inside the conversion compartment on the rear side (10), it contributes to the cooling of the passive components (coils, capacitors) housed in the conversion compartment. In this case cooling of the internal air of the compartment provides the required cooling mechanism.

- External heat exchanger (30). Placed on the external top side of the conversion compartment (10), it dissipates into the external environment the heat collected by the coolant in the cooling circuit.

- Recirculation fans (50) e (42). Internally placed, they circulate the air in order to avoid hot air stagnation inside the conversion compartment.

The entire system is factory-tested and the only checks needed during installation are to ensure that the coolant in the hydraulic circuit is at the right pressure and that no leaks are present.

The coolant liquid is a mixture of water and propylene glycol and its injection into the system requires a special pump (not supplied with the inverter).

The liquid cooling system is further equipped with heaters that prevent the coolant from freezing in case of extreme environments.



AC and user interface compartment

This section of the inverter contains the connections for the AC (output and auxiliary) voltages and the communication and control signals, and houses the auxiliary and AC output protection devices.

The output cables must be fed through the AC cable glands (78) to ensure IP65 protection rating and subsequently connected to the AC output bars (73).

The number of AC fuse groups varies according to the number of conversion modules (43) inside the ULTRA inverter. The correspondence between input bar / fuse group and conversion module is marked in this manual and on special labels affixed inside the AC and user interface compartment.

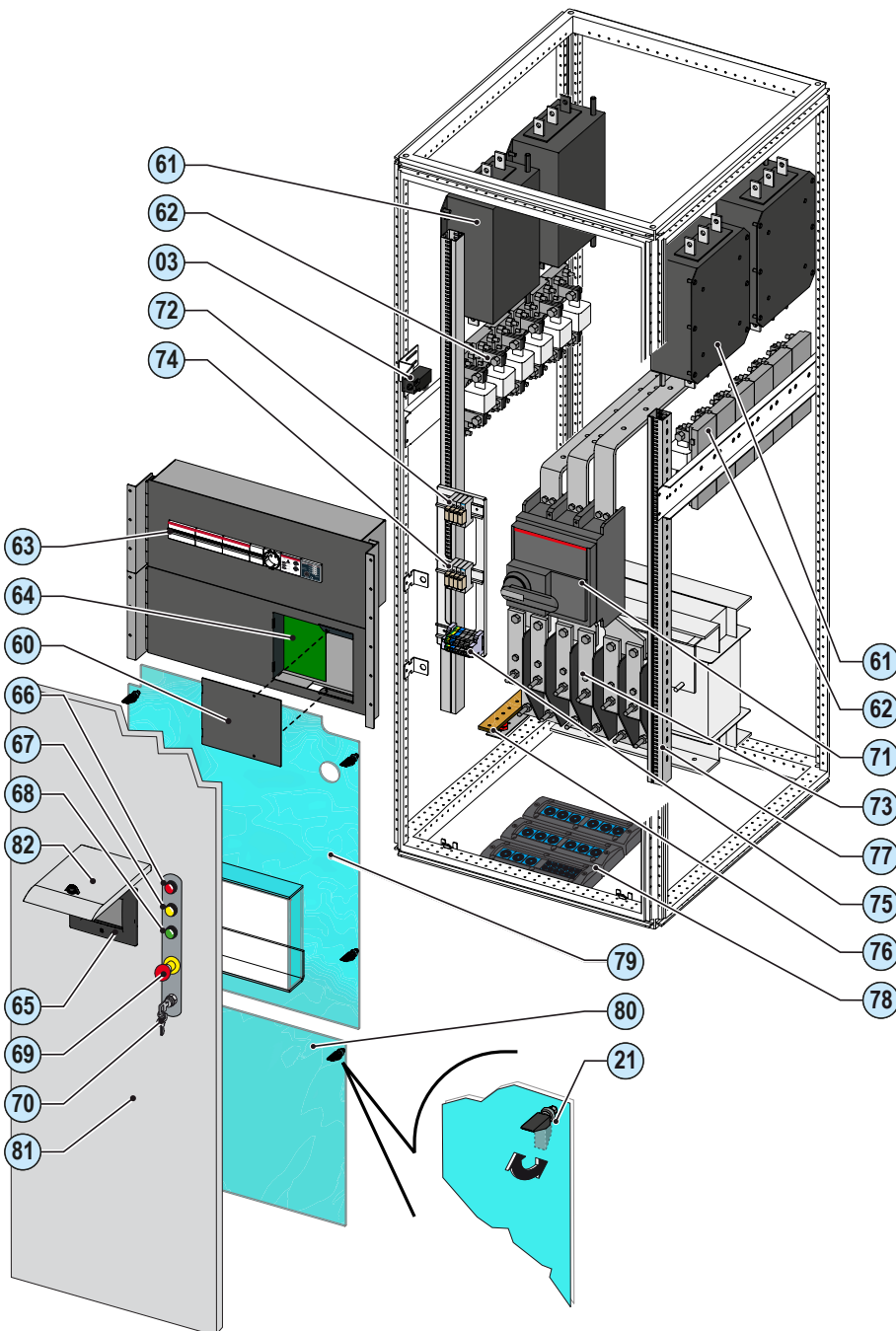

The output circuit of the conversion modules is connected to the EMI filters (61) that attenuate the harmonic components of the current fed into the grid by the inverter. The current is then driven into the AC disconnect switch (71) through the output fuses (62).

The auxiliary connector (75) and the auxiliary panel (63) allow to connect and energise the internal circuits of the inverter.

The auxiliary panel (63) also contains the communication and control board (64) that allows to connect (and configure) the inverter control and communication signals.

The user control devices are located on the AC door (81):

- Touchscreen display for viewing the inverter data
- Warning LIGHTS that indicate the status of the inverter
- Emergency button for the hardware switch-off of the inverter
- Key switch for the software switch-off of the inverter

The document and who it is for

Purpose and structure of the document

This operating and maintenance manual is a useful guide that will enable you to work safely and carry out the operations necessary for keeping the equipment in good working order.



If the equipment is used in a manner not specified in the installer manual, the protection provided by the equipment may be impaired.



The language in which the document was originally written is ITALIAN; therefore, in the event of inconsistencies or doubts please ask the manufacturer for the original document.

List of annexes

In addition to this operating and maintenance manual, (if applicable or on request) the following enclosed documentation is supplied:

- EC declaration of conformity
- quick installation guide
- warranty



WARNING: Part of the information given in this document is taken from the original documents of the suppliers. This document contains only the information considered necessary for the use and routine maintenance of the equipment.

Staff characteristics



The customer must make sure that the operator has the necessary skill and training to do his/her job. Personnel in charge of using and maintaining the equipment must be expert, aware and skilled for the described tasks and must reliably demonstrate their capacity to correctly interpret what is described in the manual.



For safety reasons, only a qualified electrician who has received training and/or demonstrated skills and knowledge on the structure and operation of the unit may install the inverter.



The installation must be performed by qualified installers and/or licensed electricians in accordance with the existing regulations in the country of installation.



The employment of a person who is NOT qualified, is drunk, or on narcotics, is strictly forbidden.



The customer has civil liability for the qualification and mental or physical state of the professional figures who interact with the equipment. They must always use the personal protective equipment required by the laws of the country of destination and whatever is provided by their employer.

Symbols ad signs

In the manual and/or in some cases on the equipment, the danger or hazard zones are indicated with signs, labels, symbols or icons.

Table: Symbols

i		This points out that it is mandatory to consult the manual or original document, which must be available for future use and must not be damaged in any way.
		Generic hazard - Important safety information. This points out operations or situations in which staff must be very careful.
		Hazardous voltage - This points out operations or situations in which staff must be very careful due to hazardous voltage.
		Hot parts - This points out a hazard due to the presence of heated areas or in any case areas that have hot parts (danger of burns).
		This points out that the examined area must not be entered or that the described operation must not be carried out.
		This points out that it is mandatory to carry out the described operations using the clothing and/or personal protective equipment provided by the employer.
		This indicates the degree of protection of the equipment according to IEC standard 70-1 (EN 60529 June 1997).
		Point of connection for grounding protection.
		This indicates the allowed temperature range
		This indicates the risk of electric shock. Time need to discharge stored energy: 5/10 minutes
		Respectively direct current and alternating current
		Isolating transformer present or not present
		Positive pole and negative pole of the input voltage (DC)
		This indicates the centre of gravity of the equipment.

Field of use, general conditions

ABB shall not be liable for any damages whatsoever that may result from incorrect or careless operations.



*You may not use the equipment for a use that does not conform to that provided for in the field of use. The equipment **MUST NOT** be used by inexperienced staff, or even experienced staff if carrying out operations on the equipment that fail to comply with the indications in this manual and enclosed documentation.*



Intended or allowed use

This equipment is an inverter designed for:
transforming a continuous electrical current (DC)
supplied by a photovoltaic generator (FV)
in an alternating electrical current (AC)
suitable for feeding into the public distribution grid.

Limits in field of use

Only a photovoltaic generator can be connected in the input of the inverter (do not connect batteries or other sources of power supply)

The inverter can be connected to the electricity grid only in countries for which it has been certified/approved.

The inverter can only be used only if all the technical characteristics are observed, as well as the conditions presented in this manual..

Improper or prohibited use



IT IS STRICTLY FORBIDDEN TO:

- *Install the equipment in environments subject to particular conditions of flammability or in adverse or disallowed environmental conditions, (temperature and humidity).*
- *Use the equipment with safety devices which are faulty or disabled.*
- *Use the equipment or parts of the equipment by linking it to other machines or equipment, unless expressly provided for.*
- *Modify operating parameters that are not accessible to the operator and/or parts of the equipment to vary its performance or change its isolation.*
- *Clean with corrosive products that could eat into parts of the equipment or generate electrostatic charges.*
- *Use or install the appliance or parts of it without having read and understood the contents of the user and maintenance manual.*
- *Heat or dry rags and clothing on the parts in temperature. In addition to being hazardous, doing so would compromise component ventilation and cooling.*



General conditions

A description of the characteristics of the equipment is given so as to identify its main components and specify the technical terminology used in the manual.

Technical terminology and the fast retrieval system for information, are supported by:

- Contents
- Reference number index

The Characteristics chapter contains information about the models, details of the equipment, characteristics and technical data, overall dimensions and identification of the equipment itself.



The customer/Installer takes full responsibility if, when reading this manual, the chronological order of its presentation established by the manufacturer is not observed. All information is provided considering occasional inclusion of that provided in previous chapters.



In certain cases, there may be a need to separately document software functionality or attach supplementary documentation to this manual intended for more qualified professionals.

Models and range of equipment

The specific models of inverters covered by this manual are divided into three groups according to their maximum output power (700 kW, 1050 kW, 1400 kW).

For inverters with the same output power the characteristics must be defined in the order form, relating primarily to:

- type of DC input compartment ⑨: 6 or 8 inputs for each conversion module ④.
- the configuration of the conversion modules ④: Multi-Master or Master-Slave
- type of input grounding: floating, positive, or negative grounding.



The choice of the inverter model must be made by a qualified technician who knows about the installation conditions, the devices that will be installed outside the inverter and possible integration with an existing system.

Each conversion module ④ is operationally independent from the others, but can work in parallel with another; this allows for implementing two different configurations.

Conversion module configurations

• ULTRA-700.0-TL (700 kW MODELS)

Multi-Master configuration:

- independent conversion modules ④ (1) and (2)
- MPPT Number → 2 (one per module)

Each conversion module ④ is connected to a dedicated array (each photovoltaic field connected to a module must be isolated from the others). In this case, each conversion module ④ activates maximum power point tracking (MPPT) in the photovoltaic generator independently from the others. This means that arrays may be installed with various positions or orientations.

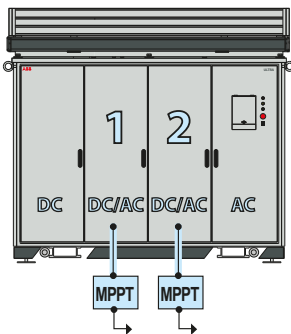

Master/Slave configuration:

- parallel conversion modules ④ (1) and (2)
- MPPT Number → 1

The conversion modules ④ are connected on the DC input side in parallel with each other. In this mode, only one of the conversion modules ④ ("MASTER" module) activates maximum power point tracking (MPPT) while the others work at the set-point indicated by the MASTER module; in this case they are known as "SLAVE" modules. This means that each array must consist of homogenous strings, characterized by the same number of panels in series and the same installation conditions (inclination and orientation)

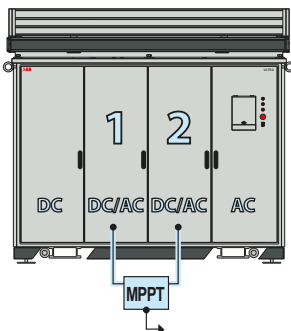

• ULTRA-1050.0-TL (1050 kW MODELS)

Multi-Master configuration:

- independent conversion modules 43 (1), (2), and (3)
- MPPT Number → 3 (one per module)

Each conversion module 43 is connected to a dedicated array (each photovoltaic field connected to a module must be isolated from the others). In this case, each conversion module 43 activates maximum power point tracking (MPPT) in the photovoltaic generator independently from the others. This means that arrays may be installed with various positions or orientations.

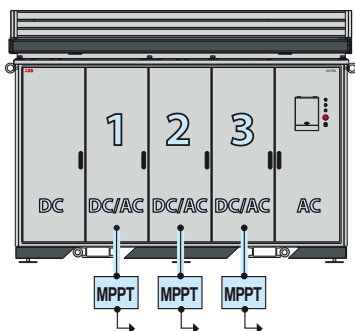

Master/Slave configuration:

- parallel conversion modules 43 (1), (2), and (3)
- MPPT Number → 1

The conversion modules 43 are connected on the DC input side in parallel with each other. In this mode, only one of the conversion modules 43 ("MASTER" module) activates maximum power point tracking (MPPT) while the others work at the set-point indicated by the MASTER module; in this case they are known as "SLAVE" modules. This means that each array must consist of homogenous strings, characterized by the same number of panels in series and the same installation conditions (inclination and orientation)

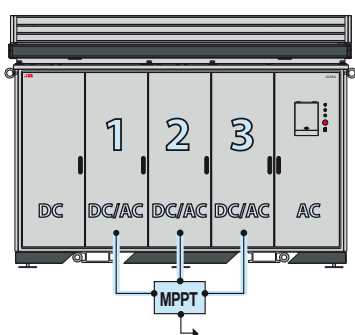

• ULTRA-1400.0-TL (1400 kW MODELS)

Multi-Master configuration:

- independent conversion modules 43 (1), (2), (3) and (4)
- MPPT Number → 4 (one per module)

Each conversion module 43 is connected to a dedicated array (each photovoltaic field connected to a module must be isolated from the others). In this case, each conversion module 43 activates maximum power point tracking (MPPT) in the photovoltaic generator independently from the others. This means that arrays may be installed with various positions or orientations.

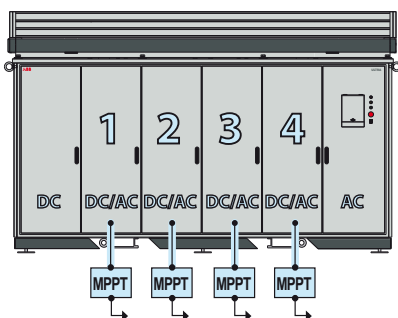

Master/Slave configuration:

- parallel conversion modules 43 (1), (2), (3) and (4)
- MPPT Number → 1

The conversion modules 43 are connected on the DC input side in parallel with each other. In this mode, only one of the conversion modules 43 ("MASTER" module) activates maximum power point tracking (MPPT) while the others work at the set-point indicated by the MASTER module; in this case they are known as "SLAVE" modules. This means that each array must consist of homogenous strings, characterized by the same number of panels in series and the same installation conditions (inclination and orientation)

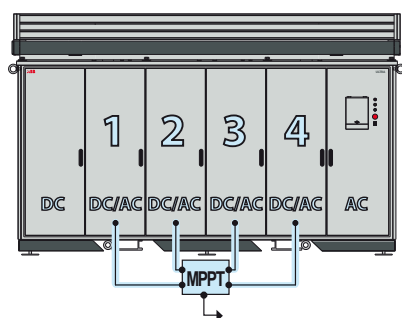

Grounding configuration of the DC inputs

Based on the photovoltaic panels used for the construction of the photovoltaic generator 3 different configurations of the DC input poles are possible:

- floating input poles
- negative pole connected to ground
- positive pole connected to ground

The configurations which provide for the grounding for one of the inverter's input poles are equipped with a grounding kit installed inside the conversion compartment ⑩ consisting of:

- Grounding resistance (100Ohm) necessary for connecting the input pole to ground
- Ground fault fuse ⑤④ and relay ⑤⑤, which intervene in the event of a ground fault at the photovoltaic generator
- Ground fault control board ⑤③

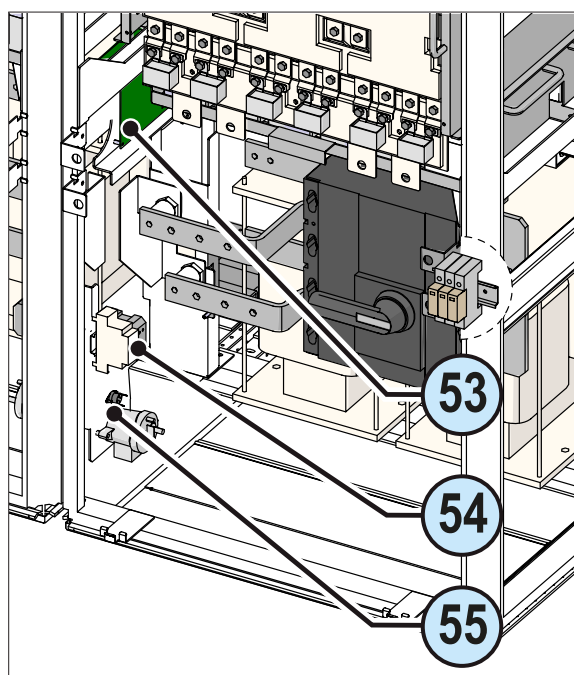

The desired configuration must be specified on the special form upon placement of the order for the inverter

Identification of the equipment and manufacturer

The technical data shown in this manual do not in any case replace those shown on the labels attached to the equipment.



The labels affixed to the equipment must NOT be removed, damaged, stained, hidden, etc., for any reason whatsoever.



Note: The labels are NOT to be hidden by foreign objects and parts (rags, boxes, equipment, etc.); they must be regularly cleaned and always kept in sight.

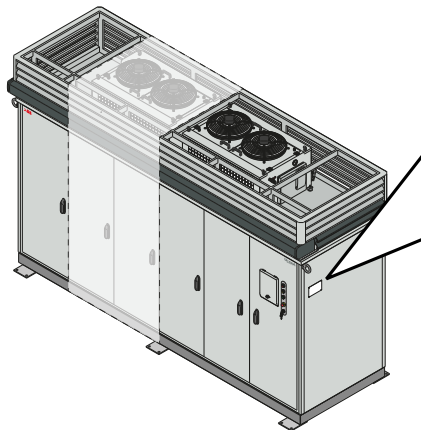

The approval label contains the following information:

1. Manufacturer
2. Model
3. Rating data
4. Certification marks



PROTECTIVE CLASS: I

Made in Italy

www.abb.com/solar

MODEL:

SOLAR INVERTER

ULTRA-700.0-TL

V_{DC} max	1000 V		V_{AC} nom	690 V 3Ø
V_{DC} MPP	470 - 900 V		f_{nom}	50 Hz
I_{DC} max	2 x 694 A		P_{AC} nom	780 kVA @ 50 °C amb.
I_{SC} max	2 x 750 A		I_{AC} max	650 A

AUXILIARY INPUT	
V_{AC} nom	400 V 3Ø
f_{nom}	50 Hz
I_{AC} max	10 A

5 minutes

 -40 to +60 °C
 -40 to +140 °F

SERIAL NUMBER

WEEK/YEAR

WEIGHT

 kg

PROTECTIVE CLASS: I

Made in Italy

www.abb.com/solar

MODEL:

SOLAR INVERTER

ULTRA-1050.0-TL

V_{DC} max	1000 V		V_{AC} nom	690 V 3Ø
V_{DC} MPP	470 - 900 V		f_{nom}	50 Hz
I_{DC} max	3 x 694 A		P_{AC} nom	1170 kVA @ 50 °C amb.
I_{SC} max	3 x 750 A		I_{AC} max	975 A

AUXILIARY INPUT	
V_{AC} nom	400 V 3Ø
f_{nom}	50 Hz
I_{AC} max	15 A

5 minutes

 -40 to +60 °C
 -40 to +140 °F

SERIAL NUMBER

WEEK/YEAR

WEIGHT

 kg

PROTECTIVE CLASS: I

Made in Italy

www.abb.com/solar

MODEL:

SOLAR INVERTER

ULTRA-1400.0-TL

V_{DC} max	1000 V		V_{AC} nom	690 V 3Ø
V_{DC} MPP	470 - 900 V		f_{nom}	50 Hz
I_{DC} max	4 x 694 A		P_{AC} nom	1560 kVA @ 50 °C amb.
I_{SC} max	4 x 750 A		I_{AC} max	1300 A

AUXILIARY INPUT	
V_{AC} nom	400 V 3Ø
f_{nom}	50 Hz
I_{AC} max	20 A

5 minutes

 -40 to +60 °C
 -40 to +140 °F

SERIAL NUMBER

WEEK/YEAR

WEIGHT

 kg

In addition to the approval label showing the inverter rating data, there is also an additional identification label located inside the AC and user interface compartment door ¹¹.

The label displays the following information:

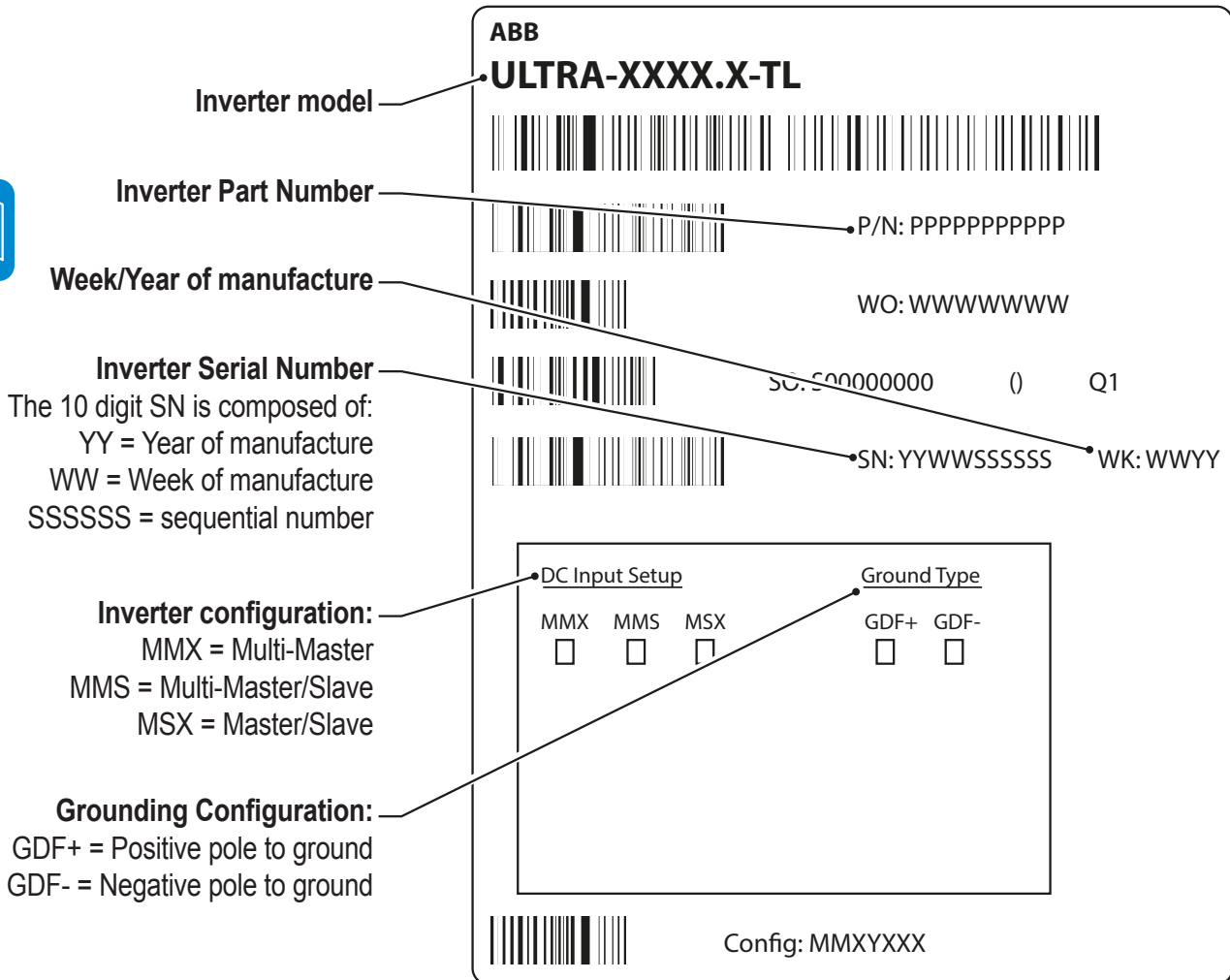

The officially required information is located on the approval label. The identification label is an accessory label which shows the information necessary for the identification and characterisation of the inverter by ABB.

Safety labels present on the inverter

Various labels are affixed to the equipment, including those bearing safety notifications and/or warnings. This type of label must be read before beginning the installation of the inverter.



Safety labels are usually identified by a yellow background.

Characteristics and technical data

Table: Technical Data ULTRA-700.0-TL ULTRA-1050.0-TL ULTRA-1400.0-TL

Input			
DC input voltage range in MPPT ($V_{MPPTmin,r} \dots V_{MPPTmax,r}$) @ $V_{ac,r}$	470...900 V Linear Derating from MAX to 7.5 kW per conversion module [850 V < V_{MPPT} < 900 V] 280 kW @ 470 V per conversion module		
DC input voltage range in MPPT ($V_{MPPTmin} \dots V_{MPPTmax}$) @ $P_{ac,r}$ and $V_{ac,r}$	585...850V@700 kW 645...850V@780 kW	585...850V@1050 kW 645...850V@1170 kW	585...850V@1400 kW 645...850V@1560 kW
Absolute Maximum Input Voltage $V_{max,abs}$	1000 V		
Number of Independent MPPT Multi-Master	2	3	4
Number of Independent MPPT Master/Slave	1	1	1
Possibility of input poles configuration	Floating / negative or positive grounding to be defined during ordering phase of the inverter ⁽⁵⁾		
Maximum Combined Input Current (I_{dcmax})	1388 (2 x 694A)	2082 (3 x 694A)	2776 (4 x 694A)
Maximum Input Current for Each Module ($I_{dcmax,m}$)	694 A	694 A	694 A
Number of DC Connection Pairs in Input (version with 6 inputs per conversion module)	12	18	24
DC Connections Type (each module , each pole)	24x50mm ² ...240mm ² (M10) ⁽⁴⁾	36x50mm ² ...240mm ² (M10) ⁽⁴⁾	48x50mm ² ...240mm ² (M10) ⁽⁴⁾
Number of DC Connection Pairs in Input (version with 8 inputs per conversion module)	16	24	32
DC Connection Type (version with 8 inputs - positive and negative poles)	32x50mm ² ...240mm ² (M10) ⁽⁸⁾	48x50mm ² ...240mm ² (M10) ⁽⁸⁾	64x50mm ² ...240mm ² (M10) ⁽⁸⁾
Input Protection			
Reverse Polarity Protection	Yes, via input disconnect switch		
Input Over Voltage Protection - SPD	1 for each module		
DC Switch Each Input Module	800 A / 1100 V		
Fuse Size Each Input Poles	up to 400 A / 1100 V		
Ground fault fuse size	2 A / 1000 V ⁽⁶⁾		
Insulation check, Floating neutral, Floating panels (IT SYSTEM)	Yes, via proprietary check ⁽⁹⁾⁽¹⁰⁾		
Output Side			
AC Grid Connection Type	Three phases 3W+PE		
Nominal AC output power ($P_{ac,r}$)	780 kVA	1170 kVA	1560 kVA
Rated Grid Voltage ($V_{ac,r}$)	690 Vac		
AC Voltage Range ($V_{acmin} \dots V_{acmax}$)	621...759 ⁽¹⁾		
Maximum Output Current ($I_{ac,max}$)	650A	975A	1300 A
Rated Frequency (fr)	50/60 Hz		
Frequency Range (fmin...fmax)	47...53 / 57...63 Hz ⁽²⁾		
Power Factor (Cosphiac,r)	>0.995 (adj. ± 0.90)		
Total Harmonic Distortion	< 3% (@ $P_{ac,r}$)		
Standard plant typology	IT ⁽⁷⁾		
AC Connections Type each phase	2x 240 mm ² (M12)	3 x 240 mm ² (M12)	4 x 240 mm ² (M12)
Output Protection			
Anti-Islanding Protection	According to local standard		
Output Overvoltage Protection - SPD	Yes (Class II)		
AC Circuit Breaker	3 x 1000 A / Icm = 52,2 kA, Icw = 20kA	3 x 1250 A / Icm = 52,2 kA, Icw = 20kA	3 x 1600 A / Icm = 52,2 kA, Icw = 20kA
AC Fuse for each module	3 X 450A/200kA		
Night Time Disconnect	Yes		



Table: Technical Data ULTRA-700.0-TL ULTRA-1050.0-TL ULTRA-1400.0-TL

Auxiliary AC voltage			
Auxiliary AC power supply connection	3W+N+PE		
Nominal auxiliary AC power supply voltage	400 Vac		
Nominal auxiliary AC power supply frequency	50/60 Hz		
Auxiliary Power Supply Consumption	< 0.50% of $P_{ac,r}$	< 0.60 % of $P_{ac,r}$	< 0.50% of $P_{ac,r}$
Auxiliary Power Supply Consumption without Cooling	< 0.05% of $P_{ac,r}$	< 0.06% of $P_{ac,r}$	< 0.05% of $P_{ac,r}$
Type of auxiliary AC connections	Screw terminal block - max cross-section 16 mm ²		
Auxiliary AC protections			
Output Overvoltage Protection - SPD	Yes (Class II)		
Auxiliary AC disconnect switch	Yes, 4 x 63 A		
Thermal-magnetic circuit breaker (per pair of conversion compartments)	Yes, 4 x 25 A		
Operating performance			
Maximum Efficiency (η_{max})	98.7% ⁽³⁾		
Weighted Efficiency (EURO/CEC)	98.2% / 98.0% ⁽³⁾		
Stand-by Consumption/Night-time power loss	< 90 W	< 110 W	< 180 W
Inverter Switching Frequency	9 kHz		
Communication			
Wired Local Monitoring	PVI-USB-RS232_485 (opt.)		
Monitoring System (PC/Data logger)	PVI-AEC-EVO (opt.), VSN700 DATA LOGGER (opt.)		
String Combiner	PVI-STRINGCOMB (opz.)		
User Interface	Touchscreen display LCD 5.7"		
Environmental			
Ambient Temperature Range	"-20...+ 60°C/-4...140°F with derating above 50°C/ 122° F -40...+ 60°C/-40...140°F with derating above 50°C/ 122° F (opt.)"		
Relative Humidity	0...100% condensing		
Noise Emission	< 78 dB(A) @ 1 m		
Maximum Operating Altitude without Derating	2000 m / 6560 ft		
Environmental pollution classification for external environment	3 outside (2 inside the IP65 enclosure)		
Environmental Category	Outdoor		
Physical			
Environmental Protection Rating	IP 65		
Cooling	Liquid and forced air		
Overvoltage Category in accordance with IEC 62109-1	II (DC input - 1000 Vdc) III (AC output - 690 Vac Phase-Phase) III (auxiliary input - 400 Vac Phase-Phase)		
Required Air Cooling Flow	13000m ³ /h 7652 ft ³ /min	26000m ³ /h 7652 ft ³ /min	26000m ³ /h 15304 ft ³ /min
Dimension (H x W x D)	2920mm x 3020mm x 1520mm / 114.9" x 118.9" x 59.9"	2920 mm x 3720 mm x 1520 / 114.9" x 146.5" x 59.9"	2920 mm x 4420 mm x 1520 / 114.9" x 174.0" x 59.9"
Weight	< 3000 kg / 6613 lbs	< 3800 kg / 8377 lbs	< 4600 kg / 10141 lbs
Weight of the module	< 55 kg / 121 lbs		
Safety			
Safety class	I		
Transformer	No (TL)		
Marking	CE (50 Hz only)		

Table: Technical Data ULTRA-700.0-TL ULTRA-1050.0-TL ULTRA-1400.0-TL

Safety and EMC Standards	EN 50178, EN62109-1, EN61000-6-2	EN61000-6-4
Grid Standard	Attachment A70 Terna, CEI-0-16, BDEW	
1. The output voltage range may vary according to the grid standard of the country of installation		
2. The output frequency range may vary according to the grid standard of the country of installation		
3. Inverter auxiliary consumption not included		
4. The maximum width for the DC input cable terminal is 30 mm; the maximum admitted diameter for the DC cables is 32.5 mm		
5. The input configuration (floating; negative or positive pole grounded) must be specified on the special form upon placement of the order for the ULTRA inverter.		
6. The ground fault fuse is installed only if one of the input poles is connected to ground		
7. The possibility to connect neutral to earth/ground (TN system) must be assessed by consulting ABB technicians		
8. The maximum width for the DC input cable terminal is 30 mm; the maximum admitted diameter for the DC cables is 25.0 mm		
9. Disconnection if the input is not balanced with respect to ground (not enabled by default)		
10. In models with grounding kit the monitoring of the 30mA Touch current and checking of the array insulation resistance are not carried out by the inverter.		



Note. Features not specifically mentioned in this data sheet are not included in the inverter product.

Tightening torques

To maintain the IP65 protection of the system and for optimal installation, the following tightening torques must be used:

Inverter

Lifting brackets fitting bolts	395.0 Nm
Support feet screws	26.0 Nm

DC input compartment

Cable lug on DC connection terminal	40.00 Nm
Roxtec cable gland locking screws	5.0 / 7.0 Nm

AC and user interface compartment ⁽¹¹⁾

Auxiliary voltage terminals	1.80 Nm
Signal terminal blocks on the communication and control board	0.25 Nm
Cable lug on AC connection bars	22.00 Nm
Cable lug on grounding connection bar	14.00 Nm
Roxtec cable gland locking screws	5.0 / 7.0 Nm

Characteristics of the LV-MV/LV-LV transformer for -TL models

The centralised version of the inverter without transformer is intended for use in systems connected with medium or low voltage (compatibly with local installation regulations) through use of a transformer guaranteeing at least one simple isolation.

Because of the inverter's rated outgoing voltage, the low voltage winding must be 320/380 V AC, while the typical medium voltage winding is 20 kV, though there may be other voltage levels, depending on the country or area of installation (10, 15, 22, 25, 27, 30, 33, 35kV).

The input of the auxiliary power supply must be galvanically isolated from the power output and must comply with the following features, specified in the technical data.

Voltage	AC connection type	Overvoltage category	Frequency
400V	Three-phase + N + PE	III	50Hz

Multi-inverter installation on a single transformer

If multiple inverters must be connected to the same transformer, all the inverters may be connected on the same secondary low voltage winding. Unlike conventional inverters, centralised ABB inverters do not require galvanic isolation between low voltage windings. A standard double winding transformer may be used (1 primary medium voltage winding, and 1 secondary low voltage winding).

The limitation on this solution depends on the breaking ability of the thermal-magnetic circuit breaker on the inverter's AC output and the impedance of the transformer, which in turn determines the maximum current of the theoretical fault that might be generated in the inverter in the event of an internal short circuit.

Type of ABB inverter	Maximum transformer power	DC voltage % (Vcc)	Secondary LV type	Secondary LV voltage	Maximum number of conversion modules connected to a single LV secondary
ULTRA	3150kVA	6%	Triangle	690V Overvoltage category II	8 (390kW conversion modules)

Verification of ambient conditions for transformer installation and scaling of the inverter parallel protection breaker is the installer's responsibility.

Overall dimensions of ULTRA-700.0-TL

The overall dimensions are given in mm

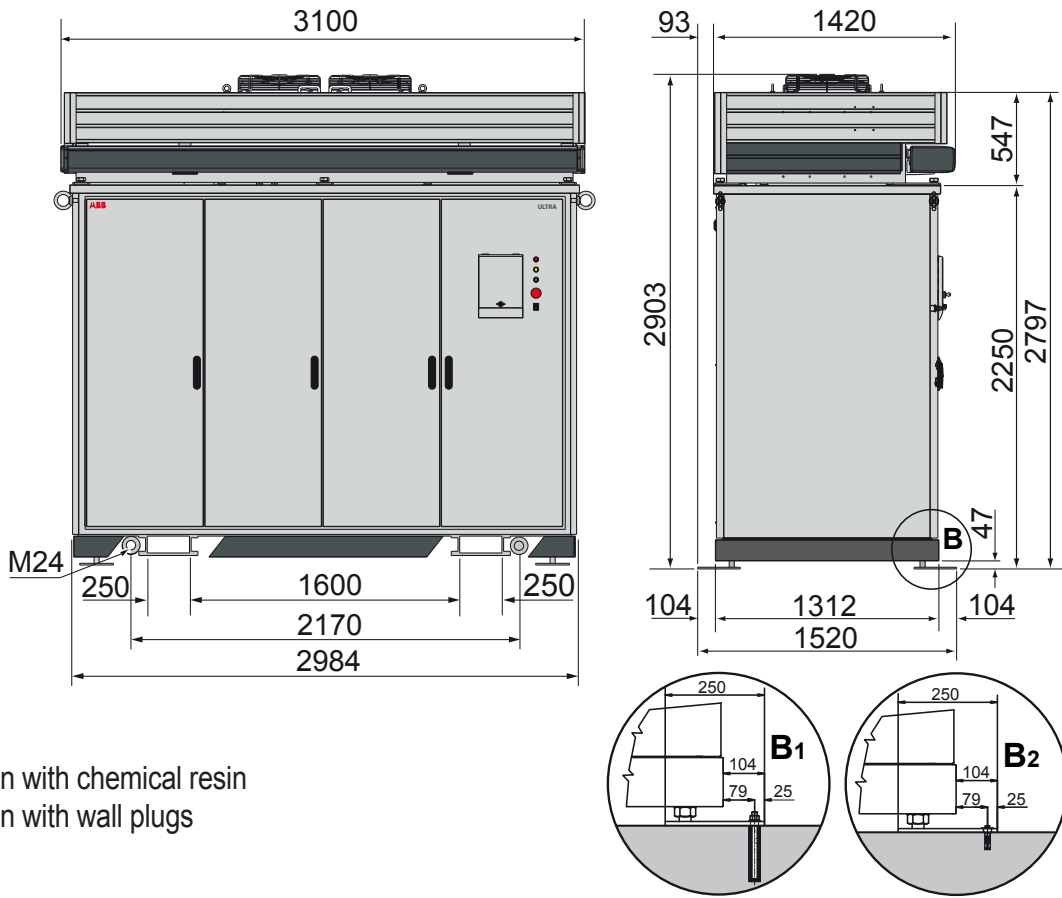

B₁ Installation with chemical resin
 B₂ Installation with wall plugs

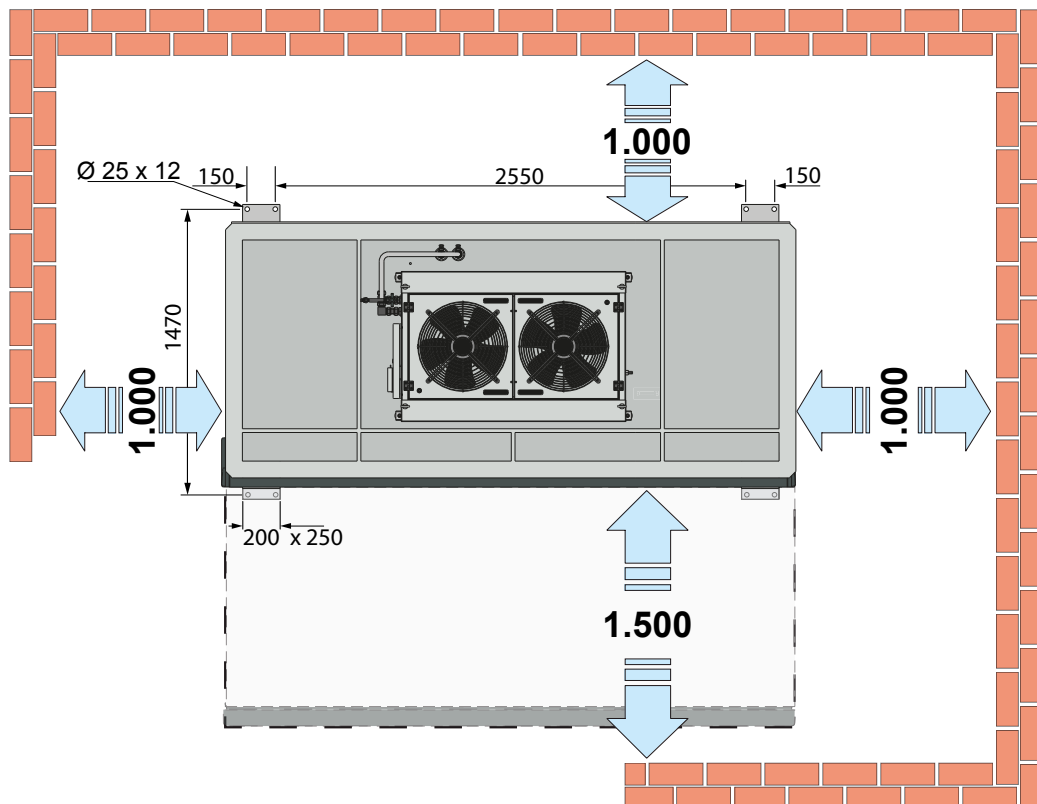

Overall dimensions of ULTRA-1050.0-TL

The overall dimensions are given in mm

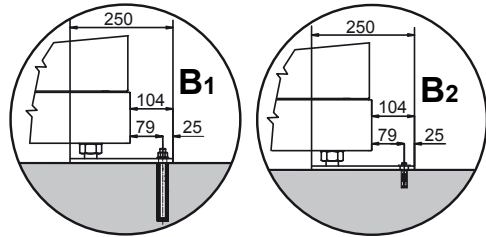
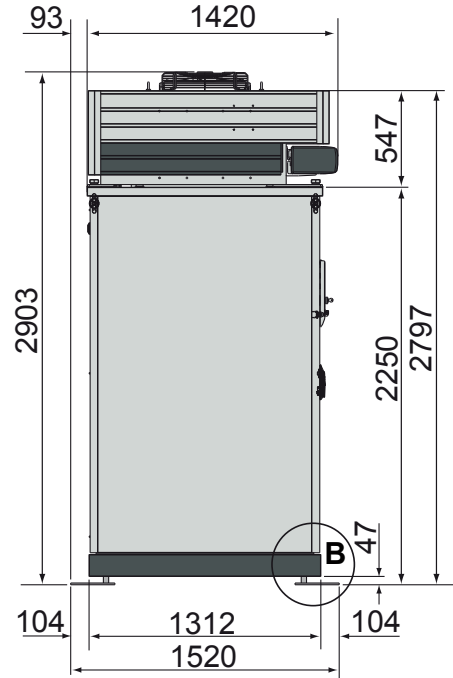
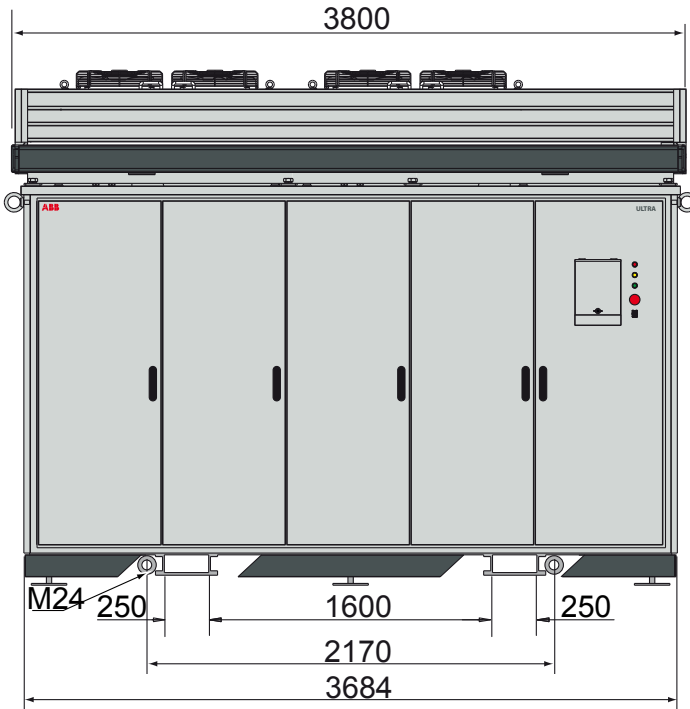

B₁ Installation with chemical resin
 B₂ Installation with wall plugs

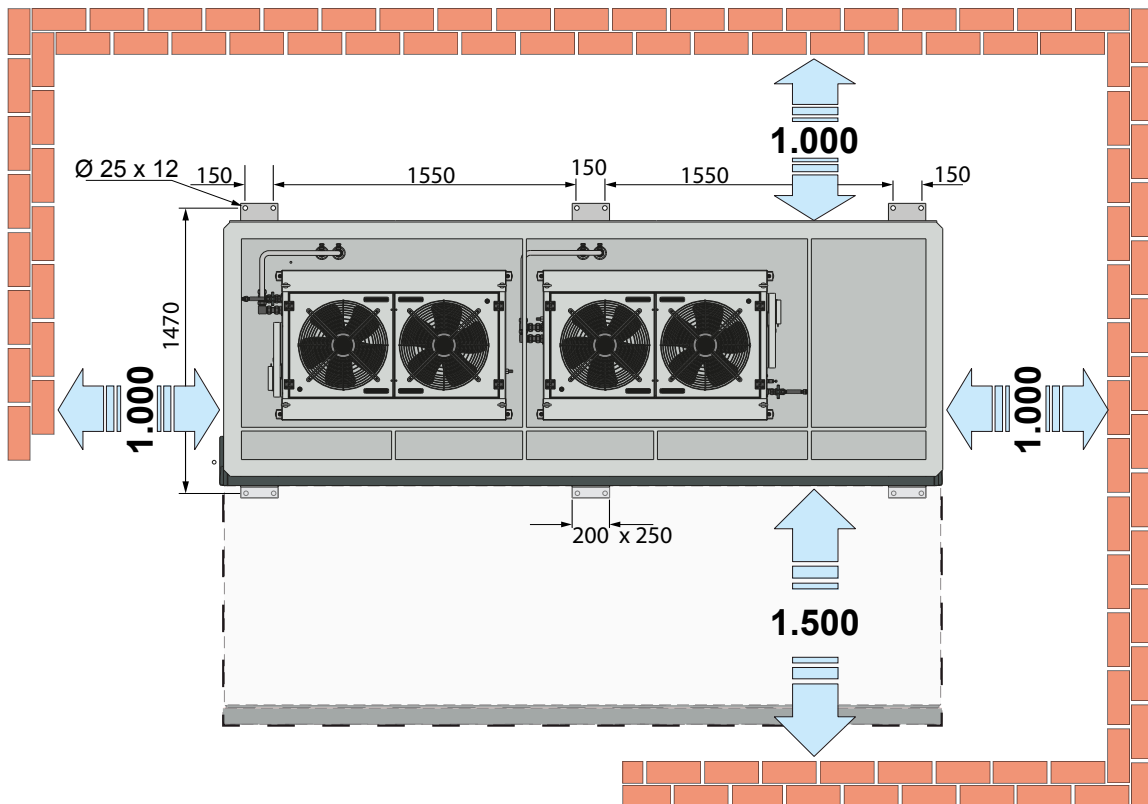

000076FG

Overall dimensions of ULTRA-1400.0-TL

The overall dimensions are given in mm

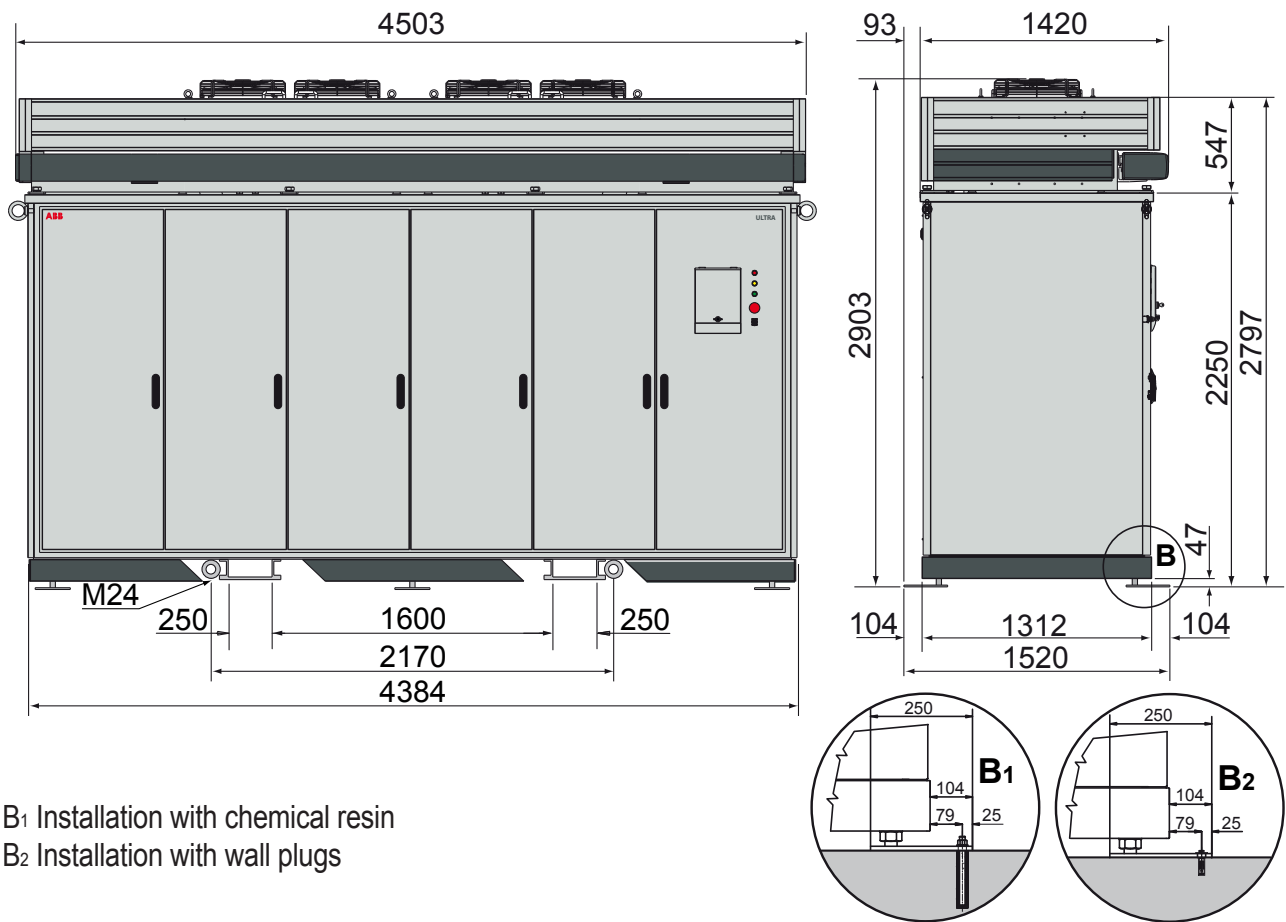

B1 Installation with chemical resin
 B2 Installation with wall plugs

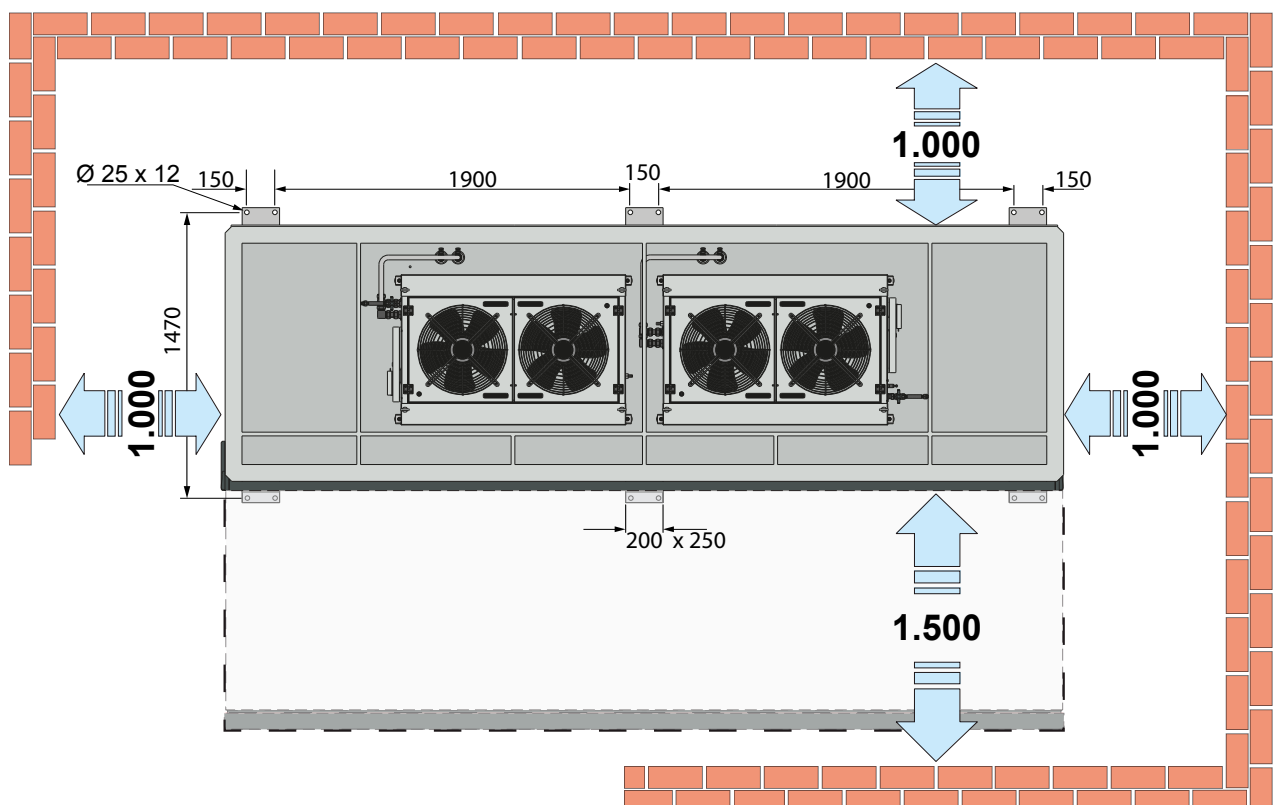

000076FG

Efficiency curves

The equipment was designed in consideration of current energy conservation standards, to avoid waste and unnecessary leakage.

Graphs of the efficiency curves of all models of inverter described in this manual are shown below.

The efficiency curves are linked to technical parameters that are continually being developed and improved and should therefore be considered approximate.



ULTRA-1400-TL-OUTD
 ULTRA-1050-TL-OUTD
 ULTRA-700-TL-OUTD

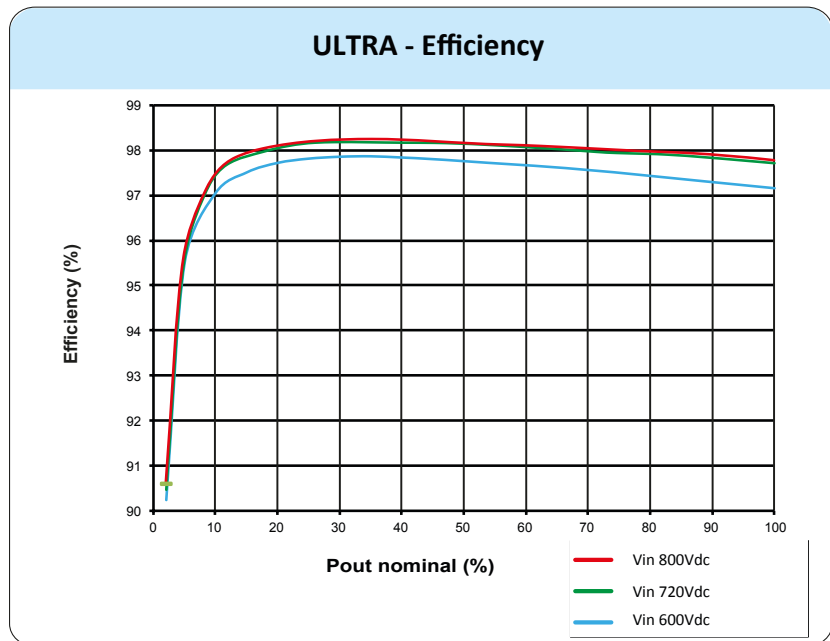

Power derating

In order to allow inverter operation in safe thermal and electrical conditions, the unit automatically reduces the value of the power fed into the grid.

Power derating can take place due to adverse environmental conditions or due to input and/or output voltage values which are not suited for full-power operation.

The circumstances that lead to power derating due to conditions associated to the environment and the input voltage can occur at the same time, but the power reduction will always be determined by the lowest detected value.

Power derating due to environmental conditions

The power reduction value and the inverter temperature at which it occurs depend on the ambient temperature and on many operating parameters. Example: input voltage, grid voltage and power available from the photovoltaic field.

The inverter can therefore reduce the power during certain periods of the day according to the value of these parameters.

ULTRA-1400-TL-OUTD
 ULTRA-1050-TL-OUTD
 ULTRA-700-TL-OUTD

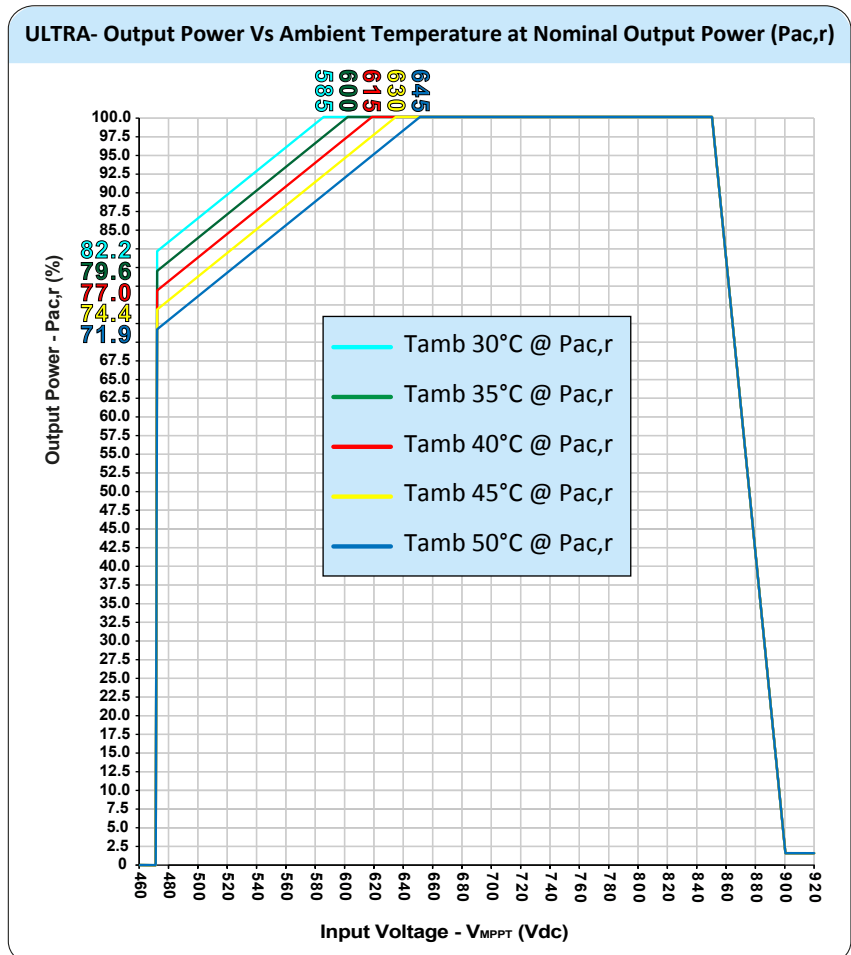

ULTRA-1400-TL-OUTD
 ULTRA-1050-TL-OUTD
 ULTRA-700-TL-OUTD

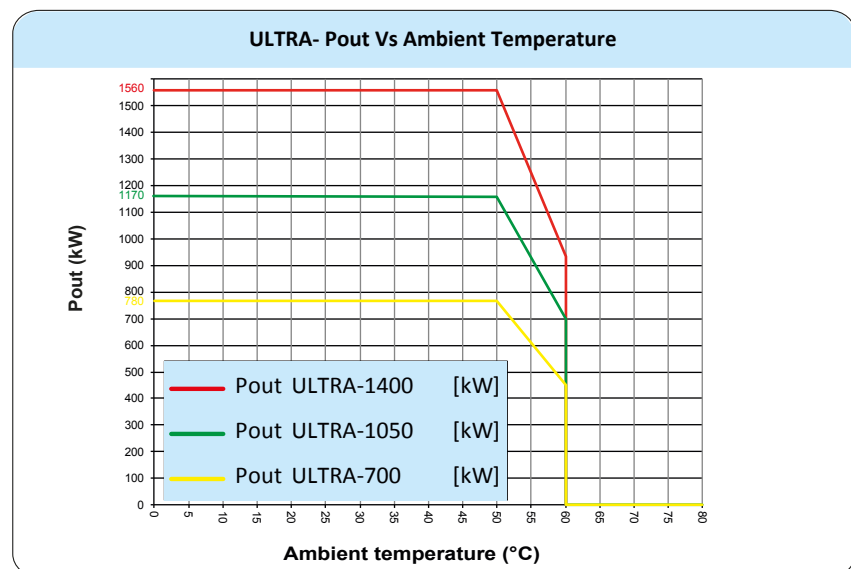

Power reduction due to the input voltage

The graphs show the automatic reduction of supplied power when input voltage values are too high or too low.

ULTRA-1400-TL-OUTD
 ULTRA-1050-TL-OUTD
 ULTRA-700-TL-OUTD

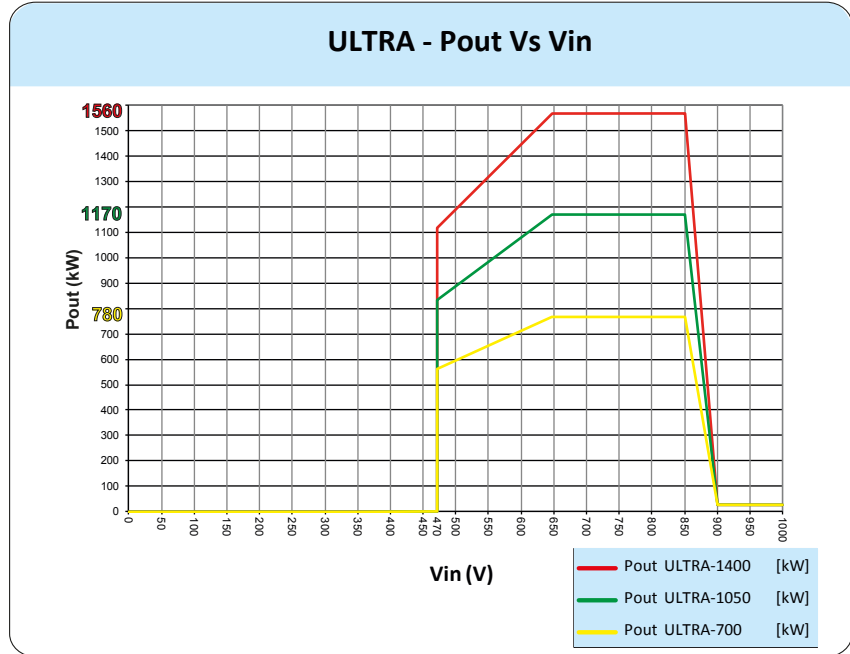

Power reduction as a function of the grid voltage

By construction, the ULTRA inverters vary the output power as a function of the grid voltage.

ULTRA-1400-TL-OUTD
 ULTRA-1050-TL-OUTD
 ULTRA-700-TL-OUTD

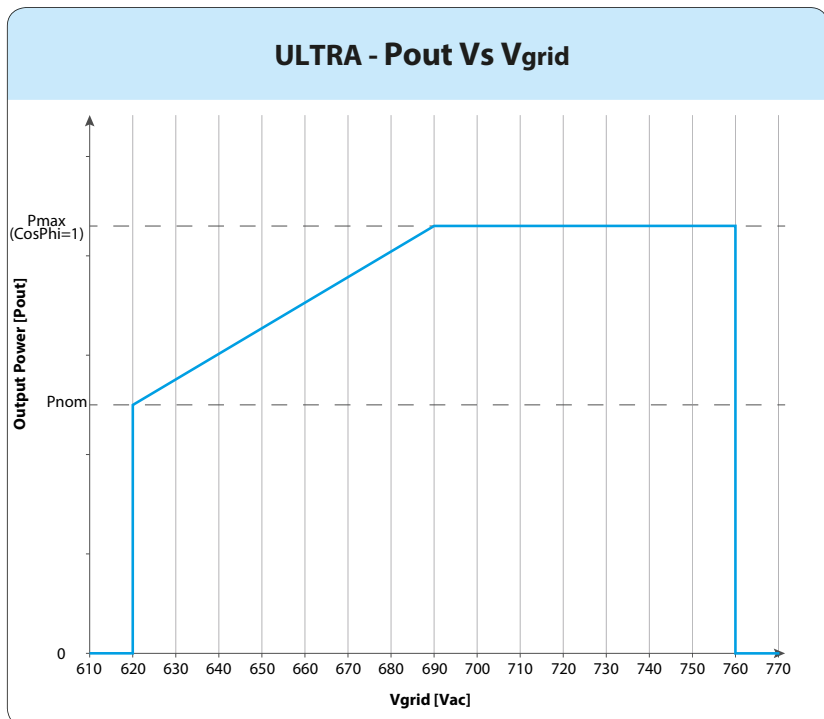

Characteristics of a photovoltaic generator

A PV generator consists of an assembly of photovoltaic panels that transform solar radiation into DC electrical energy and can be made up of:

Strings: X number of PV panels connected in series

Array: group of X strings connected in parallel

Strings and Arrays

In order to considerably reduce the cost of installing a photovoltaic system, mainly associated with the problem of wiring on the DC side of the inverter and subsequent distribution on the AC side, the string technology has been developed. A photovoltaic panel consists of many photovoltaic cells mounted on the same support.

- A string consists of a certain number of panels connected in series.
- An array consists of two or more strings connected in parallel.

Large photovoltaic systems can be made up of several arrays, connected to one or more inverters.

By maximizing the number of panels inserted into each string, it is possible to reduce the cost and complexity of the connection system of the photovoltaic system.

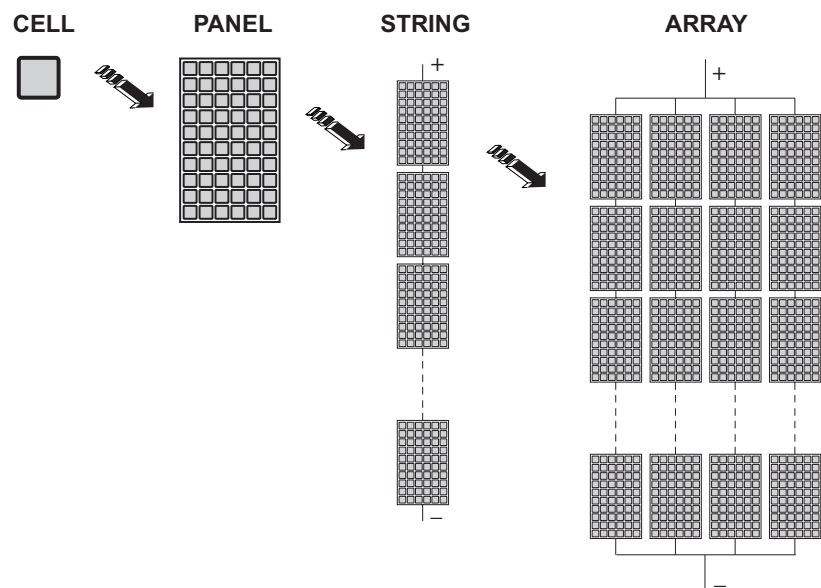

The current of each array must fall within the limits of the inverter.



To work, the inverter must be connected to the national electricity grid since its operation can be equated to a current generator that supplies power in parallel with the grid voltage. That is why inverters cannot support the grid voltage (islanding).

Description of the equipment

This equipment is an inverter for utilities of large dimensions, designed exclusively for conversion of photovoltaic energy into electrical energy compatible with the network of the country in which it is marketed.

The photovoltaic panels convert the energy irradiated by the sun into “DC” electrical energy (via a photovoltaic system, also called PV generator); using this energy requires its conversion into “AC” alternate current. This conversion, known as inversion from DC to AC, is done in an efficient way by the inverter ABB, without using any rotary elements, rather only via static electronic systems.

In order to allow inverter operation in safe thermal and electrical conditions, the unit automatically reduces the value of the power fed into the grid under adverse environmental conditions or unsuitable input voltage values.

The inverter is primarily meant for systems with connection to the MV (Medium Voltage) electricity grid, where the use and installation (on the part of the party implementing the system) of a “dedicated” MV/LV transformer in compliance with the electrical characteristics of the model of the inverter used is mandatory.

If the inverters are connected to the PVI-STRINGCOMB string combiners, it is possible to monitor the entire photovoltaic system by performing the following checks:

- String currents reading
- Total field voltage reading
- Check that internal fuses protecting the photovoltaic panels are operational.

Main characteristics

- High-performance inverters with peak efficiency up to 98.7%
- External manufacturing for use under any environmental conditions (IP65 protection rating)
- Cooling with passive liquid with total separation of internal compartments
- Direct conversion without transformer to 690 V of AC output
- Maximum input voltage up to 1000 V, allowing for high project flexibility and reducing the input distribution losses for large photovoltaic systems
- Ease of installation and maintenance. Frontally extractable conversion modules ⁴³.

Operating diagram

The drawing shows the typical main components constituting the photovoltaic system with the ULTRA inverter

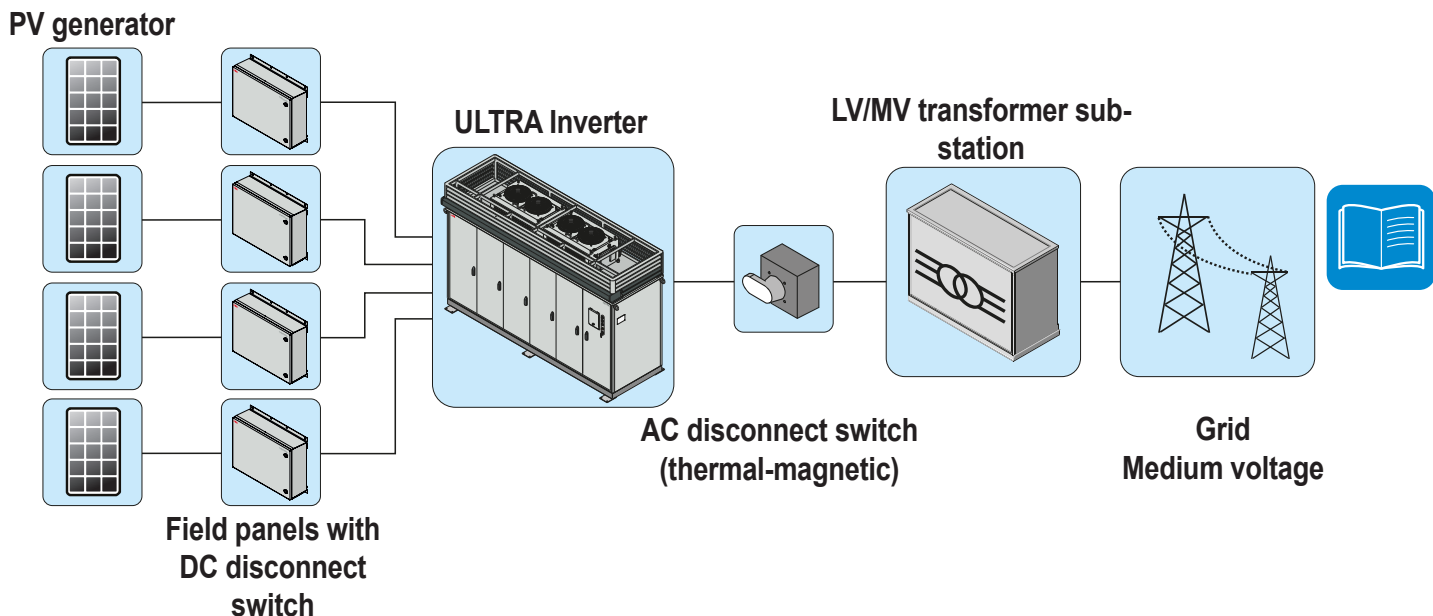

Mutual connection of multiple inverters

For photovoltaic systems where a single inverter is not sufficient, it is possible to connect multiple inverters, each of them in turn connected on the DC side to an appropriate section of the photovoltaic system itself, and on the AC side to the distribution grid (via a medium voltage transformer).

Each inverter will operate independently of the others and feed the maximum power available from its own section of PV generator to the grid.

Notes on the system sizing

Decisions on how to structure a photovoltaic system depend on a series of factors and considerations, such as the type of panels, the space availability, the future location of the system, energy production goals over the long term, etc.

A configuration program that can help to correctly set the size of the photovoltaic system is available on the **ABB** (www.abb.com) Web site.

Topographic diagram of the equipment

The ULTRA inverter is composed of conversion modules ⁽⁴³⁾, functionally independent and transformerless. It is presented as the ideal solution for multi-MW systems implemented to operate even in unfavourable environmental conditions.

The inverter can be configured with different solutions. There can be three power ratings as a function of the number of conversion modules installed on board the equipment: 700kW, 1050kW and 1400kW.

The DC/AC converters (conversion modules) are at the core of ULTRA. All converters work at a high switching frequency, and so are small and relatively light, thus facilitating maintenance.

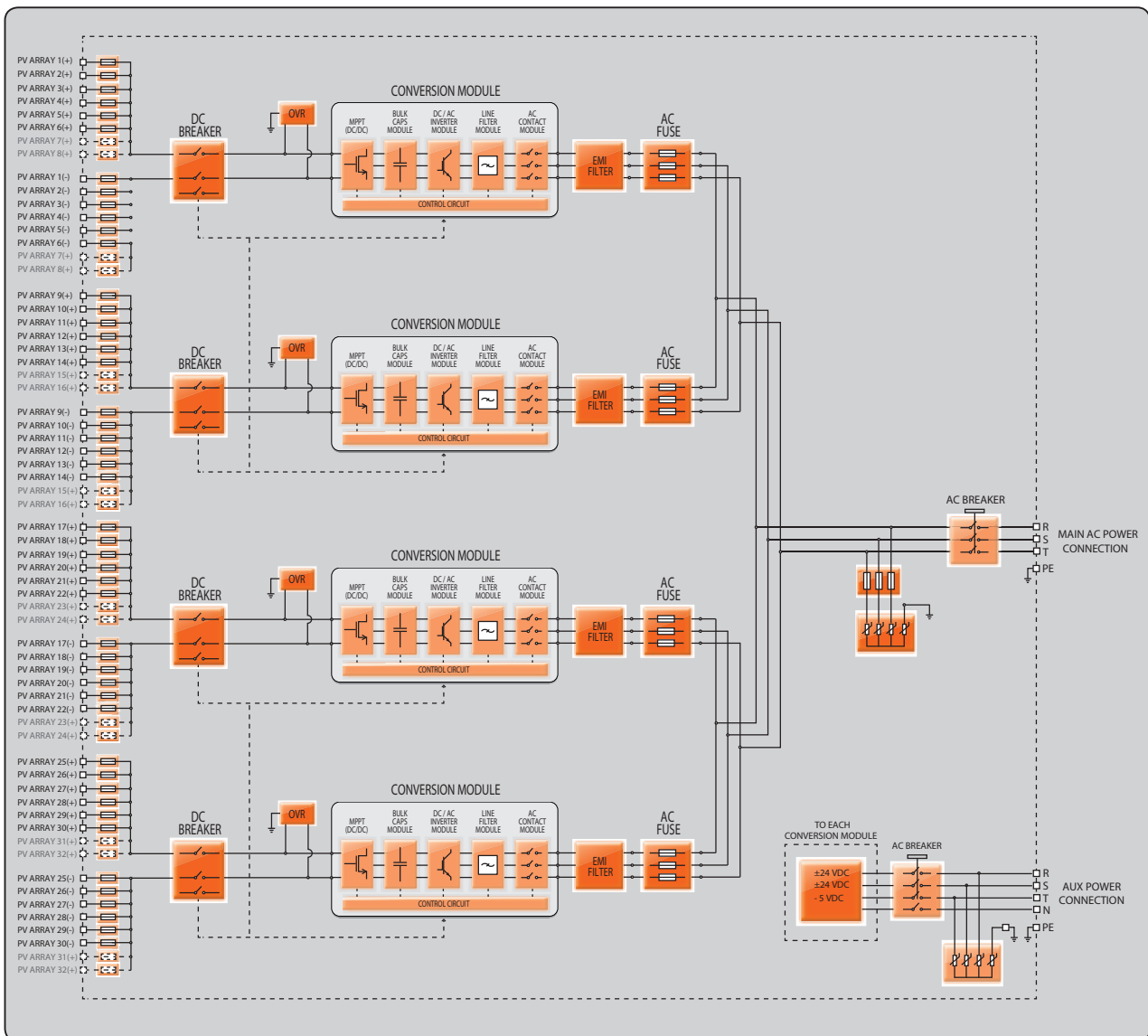

000080CG

Equipment features and components

Extractable conversion module

The liquid cooling system allows the conversion compartment ⑩ to achieve high power densities in a very limited space. The extremely compact dimensions allow the conversion module ④③ to be mounted on extractable drawers that facilitate its replacement. Module connections are ensured by the quick connection assembly ④⑨ both for the electrical and hydraulic section.

Cooling with liquid

One of the main characteristics of the inverter is that it is cooled with liquid. This allows a significant footprint reduction for a given generated power and ensures IP65 protection rating for the whole structure.



Data transmission and control

The inverter or networks of several inverters use a AURORA or ModBus communication protocol and can be remotely monitored via an advanced communication system based on a RS485 serial interface.

Auxiliary contacts (Relays)

The inverter is equipped with 4 switching relays that regulate the operation of the 4 conversion modules ④③ on board the equipment. If a lower number of conversion modules ④③ is present (700 kW and 1050 kW versions), a number of relays is installed matching the number of installed modules.

Switching of the relay state occurs when it goes from a state of feeding power to the grid to a state of disconnection from the grid (or vice versa). A typical application of auxiliary contacts is the connection of warning lights or acoustic alarm that signal any problems on the inverter.

Remote switch-on/switch-off

This control can be used to switch the inverter off/on via an external command sent via the RS485 serial line and the AURORA CVI-ULTRA software.

If this functionality is active, switching on the inverter, besides being dictated by the presence of normal parameters which allow the inverter to be connected to the grid, also depends on the external control for switching on/off.

Warning Lights

3 warning lights visible from outside the equipment, and which indicate the operating state of the inverter, are present.

Touchscreen display

The inverter is equipped with a TFT-LCD 5.7" interactive touchscreen display (on the AC door ⁸¹). The display ⁶⁵ allows to monitor the system status, i.e. the status of the conversion modules ⁴³. The display shows information on:

- The operating state of the conversion modules and statistical data
- The operating state of all the PVI-STRINGCOMBs connected to the inverter.
- Alarm messages
- The operating state of the cooling system

SD card

The rear of the display houses a SD memory card, where the inverter statistical data are stored during operation; the files necessary for the correct operation of the display are also installed on the card.

Control on the active/reactive power fed into the grid by the grid company

The inverter is capable of feeding reactive power into the grid, besides active power, through this connection, by setting the phase factor. The power feeding management may be directly monitored by the grid company. This task can be performed by the PVI-PMU device (optionally integrated in the inverter) or via RS485 serial commands (Aurora or Modbus communication protocols).

Power feeding modes vary according to the country of installation and the grid companies. For detailed information on the parameters and characteristics of this function, contact ABB directly.

Safety devices

The equipment is provided with both software and hardware protection devices that guarantee a redundant structure for a strictly safe operation, including:

- DC input protection fuses ²² with monitoring function
- AC output protection fuses ⁶² with monitoring function
- DC overvoltage surge arresters ⁴⁸ with monitoring function
- AC overvoltage surge arresters ⁷² with monitoring function
- auxiliary overvoltage surge arresters ⁷⁴ with monitoring function
- emergency button ⁶⁹ that opens the inverter internal AC and DC disconnect switches
- safety switches ⁰³, on board each module that perform a software switch-off when the doors are open

Protective awning

The inverter is equipped with a protective awning ⁰¹ installed on the top part of the front cover.

The awning is used to protect operators and inverter internal components from rain or sunlight during installation or maintenance operations. To unfold the protective awning ⁰¹ rotate the hook located on the left side using the special crank handle ¹² provided.

The crank handle is located in the DC input compartment ⁰⁹ and it must always be stored back after use.

*Always remember to fold the awning at the end of any installation or maintenance operations!
The awning is NOT designed to protect the inverter from sunlight or adverse environmental conditions during normal operation!*

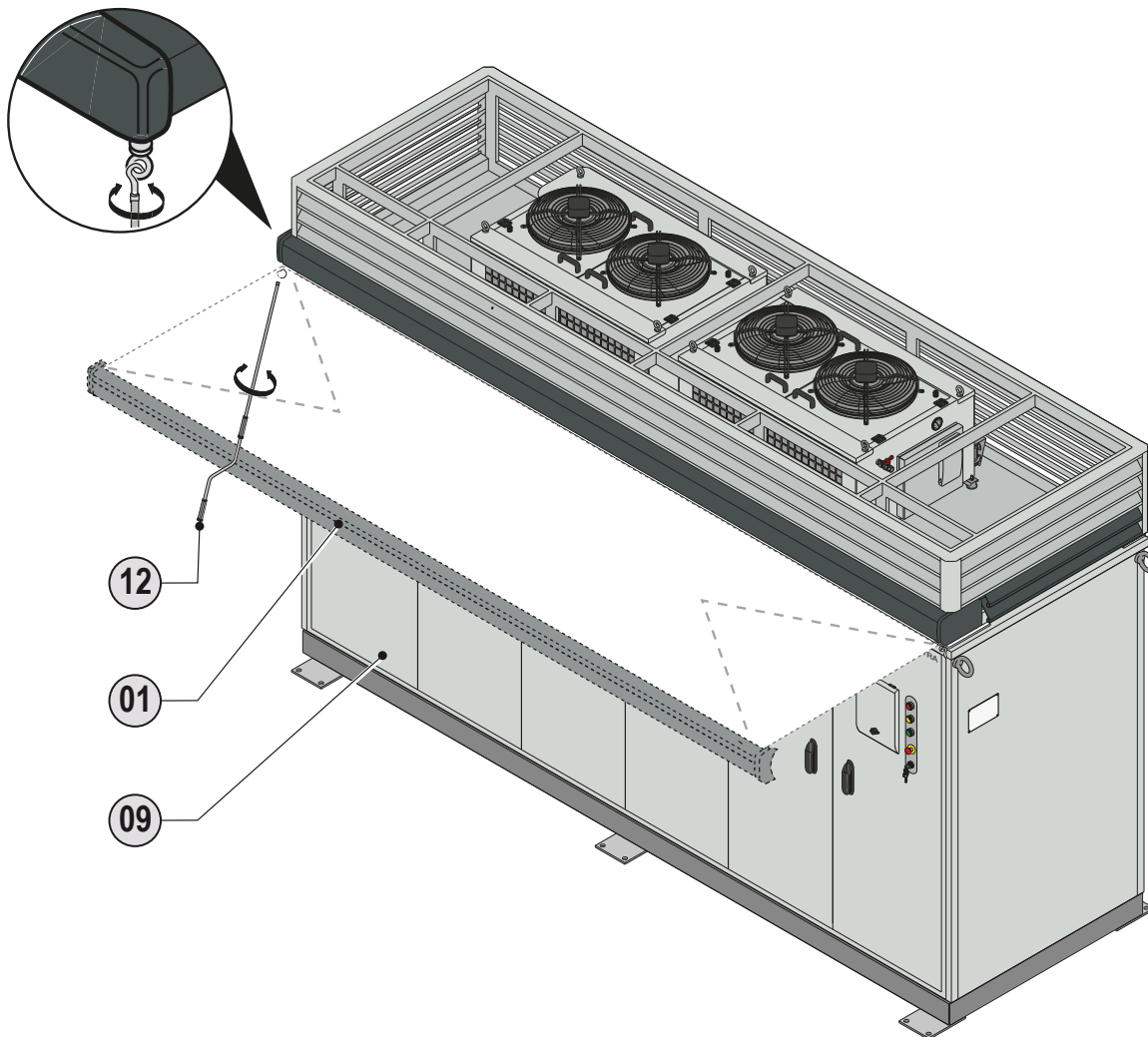

Safety devices

Anti-Islanding

In the event of a local grid outage by the electricity company, or when the equipment is switched off for maintenance operations, the inverter must be physically disconnected to ensure the protection of the people working on the grid, in accordance with the relevant national laws and regulations. To prevent possible islanding, the inverter is equipped with an automatic safety disconnection system called “Anti-Islanding”



Protection fuses

The DC input compartment ⁰⁹ includes 12 or 16 DC input protection fuses ²² (6 on the positive pole and 6 on the negative pole for the 6-input version, or 8 on the positive pole and 8 on the negative pole for the 8-input version) for each conversion module ⁴³.

The number of DC fuses installed within the equipment is therefore:

- 24 for the 700 kW model with 6-input DC input compartment ⁰⁹ version (12 fuses connected to the positive poles and 12 fuses connected to the negative poles).
- 32 for the 700 kW model with 8-input DC input compartment ⁰⁹ version (16 fuses connected to the positive poles and 16 fuses connected to the negative poles).
- 36 for the 1050 kW model with 6-input DC input compartment ⁰⁹ version (18 fuses connected to the positive poles and 18 fuses connected to the negative poles).
- 48 for the 1050 kW model with 8-input DC input compartment ⁰⁹ version (24 fuses connected to the positive poles and 24 fuses connected to the negative poles).
- 48 for the 1400 kW model with 6-input DC input compartment ⁰⁹ version (24 fuses connected to the positive poles and 24 fuses connected to the negative poles).
- 64 for the 1400 kW model with 8-input DC input compartment ⁰⁹ version (32 fuses connected to the positive poles and 32 fuses connected to the negative poles).

The AC and user interface compartment ¹¹ contains 3 AC output protection fuses ⁶² (one for each phase) for each conversion module ⁴³ on board:

- 6 for the 700 kW model (2 fuses for each phase).
- 9 for the 1050 kW model (3 fuses for each phase).
- 12 for the 1400 kW model (4 fuses for each phase).

Overvoltage surge arresters

As an additional protection to prevent possible damage caused by discharges from lightning and electrostatic induction phenomena, the unit is equipped with DC overvoltage surge arresters ⁴⁸ (installed on board each conversion compartment ¹⁰), AC overvoltage surge arresters ⁷² for the 690 V AC output and auxiliary overvoltage surge arresters ⁷⁴ for the auxiliary panel utilities ⁶³ (installed on board the AC and user interface compartment ¹¹).

All surge arresters are of interchangeable cartridge type.



Monitoring the components

The status of the main internal components of the inverter is monitored by the control logic; if a fault is detected, this is reported and made available on the display ⁶⁵ and signalled by the warning lights on the AC door front panel ⁸¹.

Monitoring may also be performed using remote devices (if present).

The main monitored components are:

- DC input protection fuses ²² and AC output protection fuses ⁶²
- DC overvoltage surge arresters ⁴⁸, AC overvoltage surge arresters ⁷² and auxiliary overvoltage surge arresters ⁷⁴
- DC disconnect switch ⁴⁷
- AC disconnect switch ⁷¹
- AC contactors ⁴¹ installed on each conversion compartment ¹⁰
- external heat exchanger ³⁰
- conversion module ⁴³

Other protective devices

The inverter is equipped with additional protective devices to ensure safe operation. These protections include:

- Isolation and thus protection of the 3 RS485 serial lines. The communication and control board ⁶⁴ decouples the equipment internal logic
- Constant monitoring of the grid voltage to ensure that voltage and frequency values remain within the operating range;
- Thermal-magnetic switch installed on the auxiliary panel ⁶³ and connected to the auxiliary power grid input (1 for the 700 kW version and 2 for the 1050 and 1400 kW versions).
- Monitoring of the internal temperature to automatically limit the power if necessary to prevent unit overheating (derating).
- Monitoring of the input voltages (for each MPPT) to automatically limit the power if necessary (derating).

The numerous control systems determine a redundant structure to ensure absolutely safe operations.

Safety instructions and general information

The equipment has been manufactured in accordance with the strictest accident-prevention regulations and supplied with safety devices suitable for the protection of components and operators.



For obvious reasons, it is not possible to anticipate the great number of installations and environments in which the equipment will be installed; it is therefore necessary for the customer to appropriately inform the manufacturer about particular installation conditions.

ABB accepts no liability for failure to comply with the instructions for correct installation are cannot be held responsible for the systems upstream or downstream of the equipment it has supplied.



It is essential to provide operators with correct information. They must therefore read and comply with the technical information given in the manual and in the attached documentation.

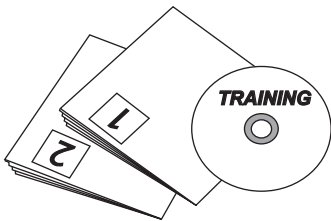

The instructions given in the manual do not replace the safety devices and technical data for installation and operation stuck on the product, and they certainly do not replace the safety regulations in force in the country of installation and common sense rules.

The manufacturer is willing to train staff, at its premises or on site, in accordance with conditions to be set out in the contract.



Do not use the equipment if you find any operating anomalies.

Avoid temporary repairs. All repairs should be carried out using only genuine spare parts, which must be installed in accordance with their intended use.

Liabilities arising from commercial components are delegated to the respective manufacturers.

Hazardous areas and operations

Environmental conditions and risks

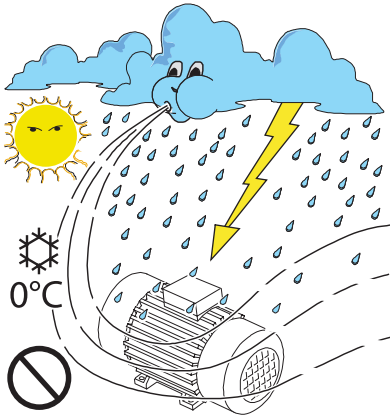

The equipment can be installed outdoors, but only in environmental conditions that do not prevent its regular operation. These conditions are reported on the technical data and on installation chapter.

ABB CANNOT be held responsible for disposal of the equipment: displays, cables, batteries, accumulators, etc., and therefore the customer must dispose of these substances, which are potentially harmful to the environment, in accordance with the regulations in force in the country of installation.

The same precautions should be adopted for dismantling the equipment.



The equipment is not equipped to operate in environments that have particular flammability or explosive conditions.

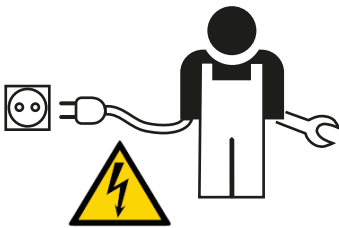

The customer and/or installer must appropriately train operators or anyone who may come near the equipment, and highlight, if necessary with notices or other means, the hazardous areas or operations at risk if required: magnetic fields, hazardous voltages, high temperatures, possibility of discharges, generic hazard, etc.

Signs and Labels



The labels attached to the equipment must absolutely **NOT** be removed, damaged, dirtied, hidden, etc.

The labels must be cleaned regularly and kept visible at all times, that is, they must **NOT** be hidden with objects and extraneous parts (rags, boxes, equipment, etc.)

The technical data shown in this manual do not in any case replace those shown on the labels attached to the equipment.

Thermal hazard



WARNING: removal of guards or covers is allowed only 10 minutes after the voltage has been removed; ; this is to let components cool down and allow any electrostatic charges and parasitic voltages to be discharged.

When the equipment has just been switched, it may have hot parts, as a result of overheating of the surfaces at temperature (e.g.: transformers, accumulators, coils, etc.) so be careful where you touch.

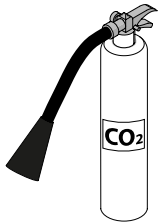

In the event of fire, use CO₂ extinguishers and use auto extraction systems to fight fire in closed environments.

Clothing and protective devices for staff



ABB has eliminated sharp edges and corners, but in some cases it is not possible to do anything, and we therefore advise wearing the clothing and personal protective devices provided by the employer.



Staff must not wear clothes or accessories that can start fires or generate electrostatic charges or, in gener, clothing that can impede personal safety.



All operations on the equipment should be performed with suitably insulated clothes and instruments.

E.g.: Insulated gloves (class 0, category RC)

Maintenance operations must be carried out with the equipment disconnected from the grid and from the photovoltaic generator.

Staff must **NOT** go near the equipment with bare feet or wet hands.

The maintenance technician must in any case make sure no one else can switch on or operate the equipment during the maintenance operations, and must report any anomaly or damage due to wear or ageing so that the correct safety conditions can be restored.

The installer or maintenance technician must always pay attention to the work environment, so that it is well lit and has sufficient spaces to ensure they have an escape route.



In the installation, consider or make sure the **noise emitted based on the environment** is not such that it exceeds thresholds allowed by law (less than 80 dBA).

Residual risks



Despite the warnings and safety systems, there are still some residual risks that cannot be eliminated.

These risks are listed on the following table with some suggestions to prevent them.

Table: residual risks

RISK ANALYSIS AND DESCRIPTION	SUGGESTED REMEDY
Noise pollution due to installation in unsuitable environments or where personnel work permanently.	Reassess the environment or the spot for installation.
Suitable local ventilation that does not cause overheating of the equipment and is sufficient not to create discomfort to people in the room.	Restore suitable ambient conditions and ventilate the room.
Overheating of surfaces at high temperatures (transformers, accumulators, coils, etc.) can cause burns. Pay particular attention not to block any of the device's cooling slats or systems.	Use suitable protective equipment or wait for the parts to cool down before switching the device on.
Inadequate cleaning: jeopardises cooling and prevents reading of the safety labels.	Clean the device, the labels and the work environment adequately.
Accumulation of electrostatic energy can generate hazardous discharges.	Ensure the devices have discharged their energy before working on them.
Inadequate training of staff.	Ask for a supplementary course.
During installation, the provisional mounting of the equipment or its components may pose safety risks	Carefully monitor and restrict access to the installation area.



General conditions

Some recommendation apply only to large size product or multiple small size packings.

Transport and handling

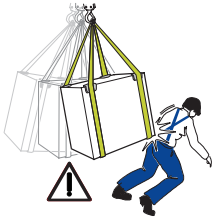

Transport of the equipment, especially by road, must be carried out with by suitable ways and means for protecting the components (in particular, the electronic components) from violent shocks, humidity, vibration, etc.

During handling, do not make any sudden or fast movements that can create dangerous swinging.

Lifting



ABB usually stores and protects individual components by suitable means to make their transport and subsequent handling easier, but as a rule it is necessary to turn to the experience of specialized staff in change of loading and unloading the components.

Where indicated and/or where there is a provision, eyebolts or handles, which can be used as anchorage points, are inserted and/or can be inserted.

The ropes and means used for lifting must be suitable for bearing the weight of the equipment.

Do not lift several units or or parts of the equipment at the same time, unless otherwise indicated.

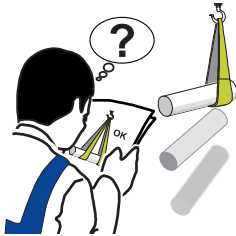
Unpacking and checking

We remind you that the packaging elements (cardboard, cellophane, staples, adhesive tape, straps, etc.) may cause cuts and/or injuries if not handled with care. They should be removed by suitable means and not left in the hands of irresponsible people (e.g., children).

The components of the packaging must be disposed on in accordance with the regulations in force in the country of installation.

When you open the package, check that the equipment is undamaged and make sure all the components are present.

If you find any defects or damage, stop unpacking and consult the carrier, and also promptly inform the Service ABB.

Mode of lifting



All ULTRA models must not be inclined during lifting and transport.

Lifting can be done in 2 modes:

- lifting with packaging
- lifting without packaging

in both cases, it is possible to use forks and fork-lift trucks (with receptacle on the front longitudinal side) or cables provided with suitable fork balances for pulling vertically.



When fitting the harness for lifting, consider as reference the centre of mass of marked by the special symbol on the equipment and packaging.

Lifting with packaging

The packaging is suitable for supporting the load of a single device.

The packaging walls, even though they are robust and provided with transversal struts, cannot hold lateral loads, which is why it is not possible to use cables or chains coming in contact with the packaging in the upper part.

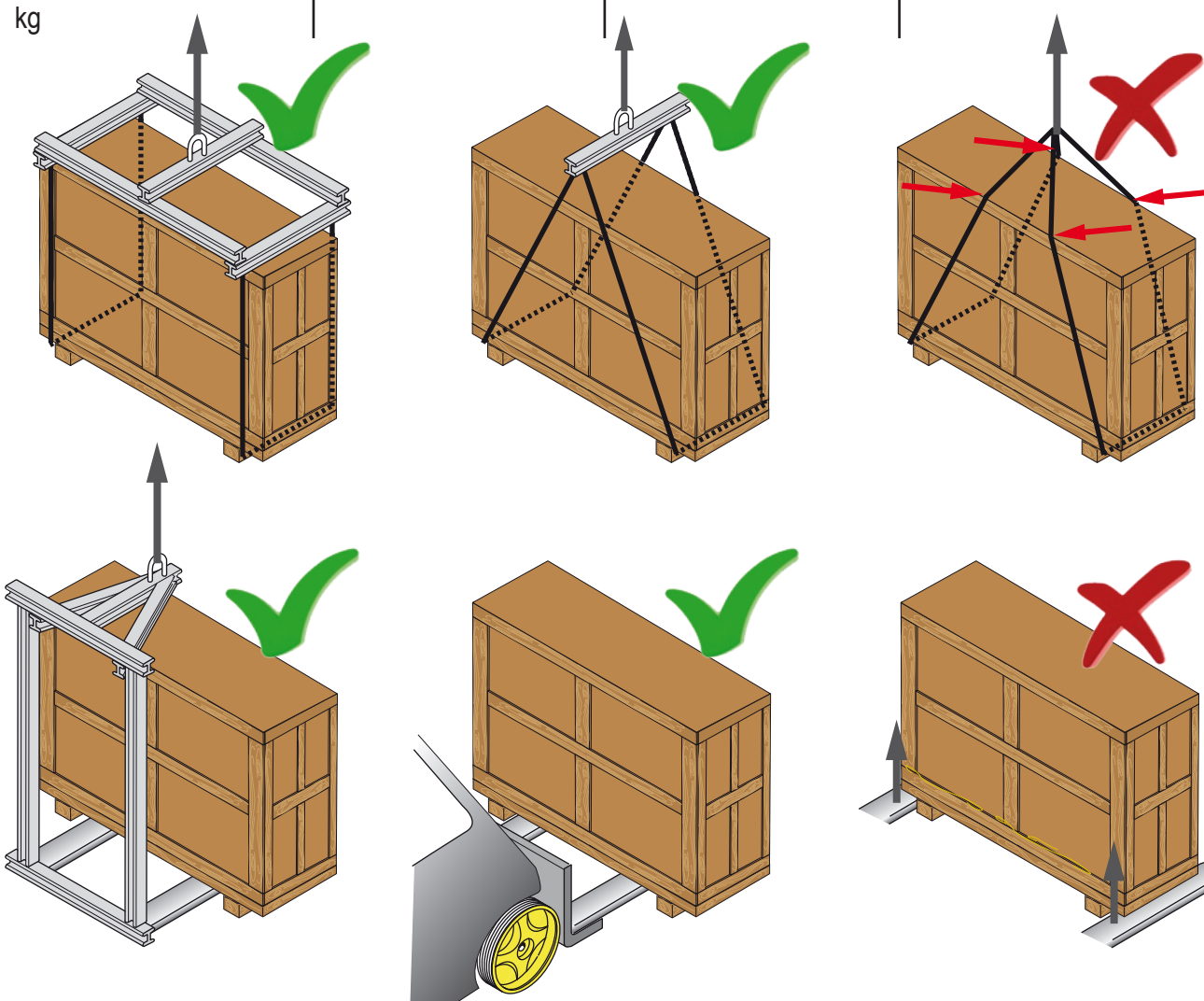
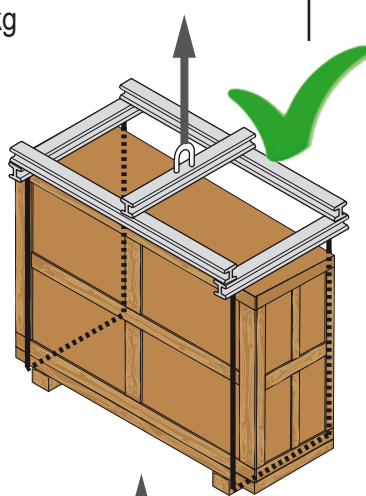
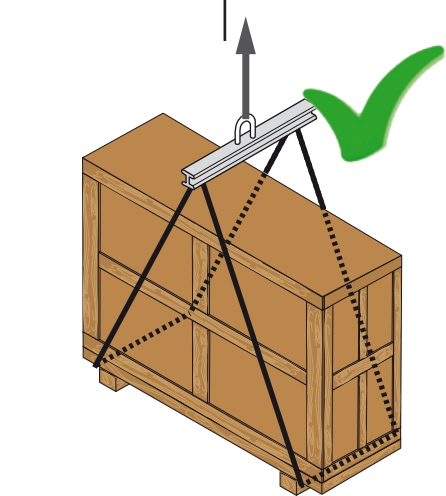
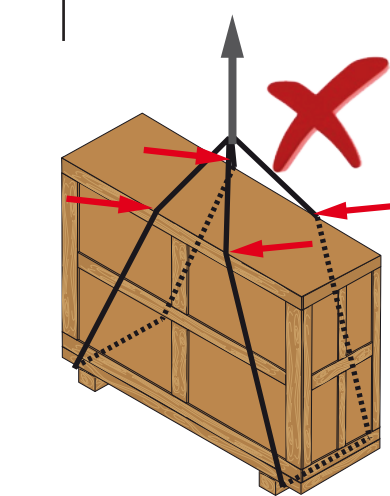
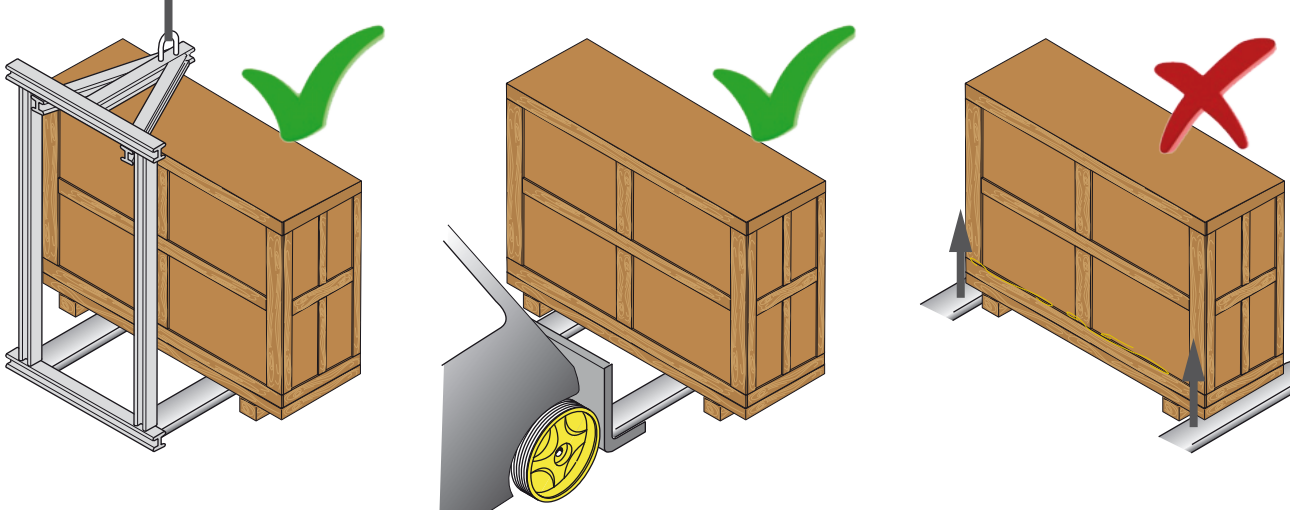
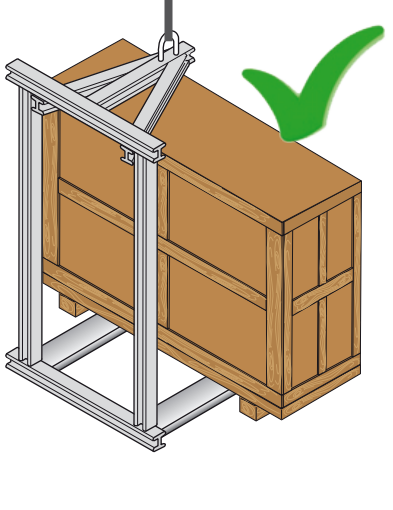
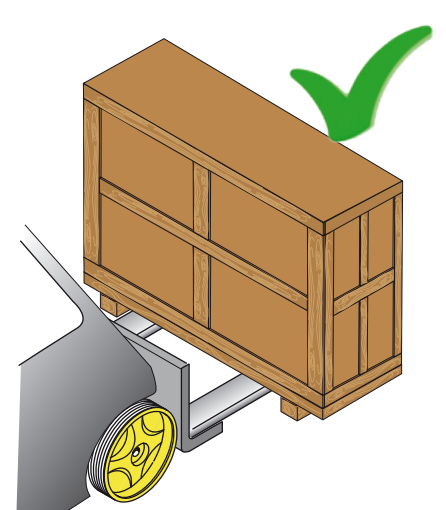
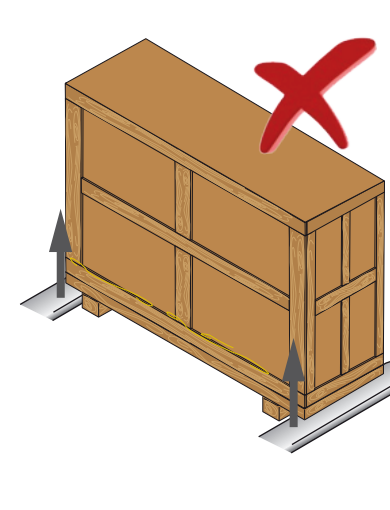
	ULTRA 700 kW	ULTRA 1050 kW	ULTRA 1400 kW
Weight with packaging in kg	~ 3.400	~ 4.200	~ 5.000
			
			

Lifting without packaging

After removing the packaging side walls, it is necessary to detach the ropes and bolts that secure the inverter to the underlying wooden pallet on the support feet 04.

The eyebolts 02 mounted on the inverter top section must be removed and the corresponding holes closed with the supplied covers.

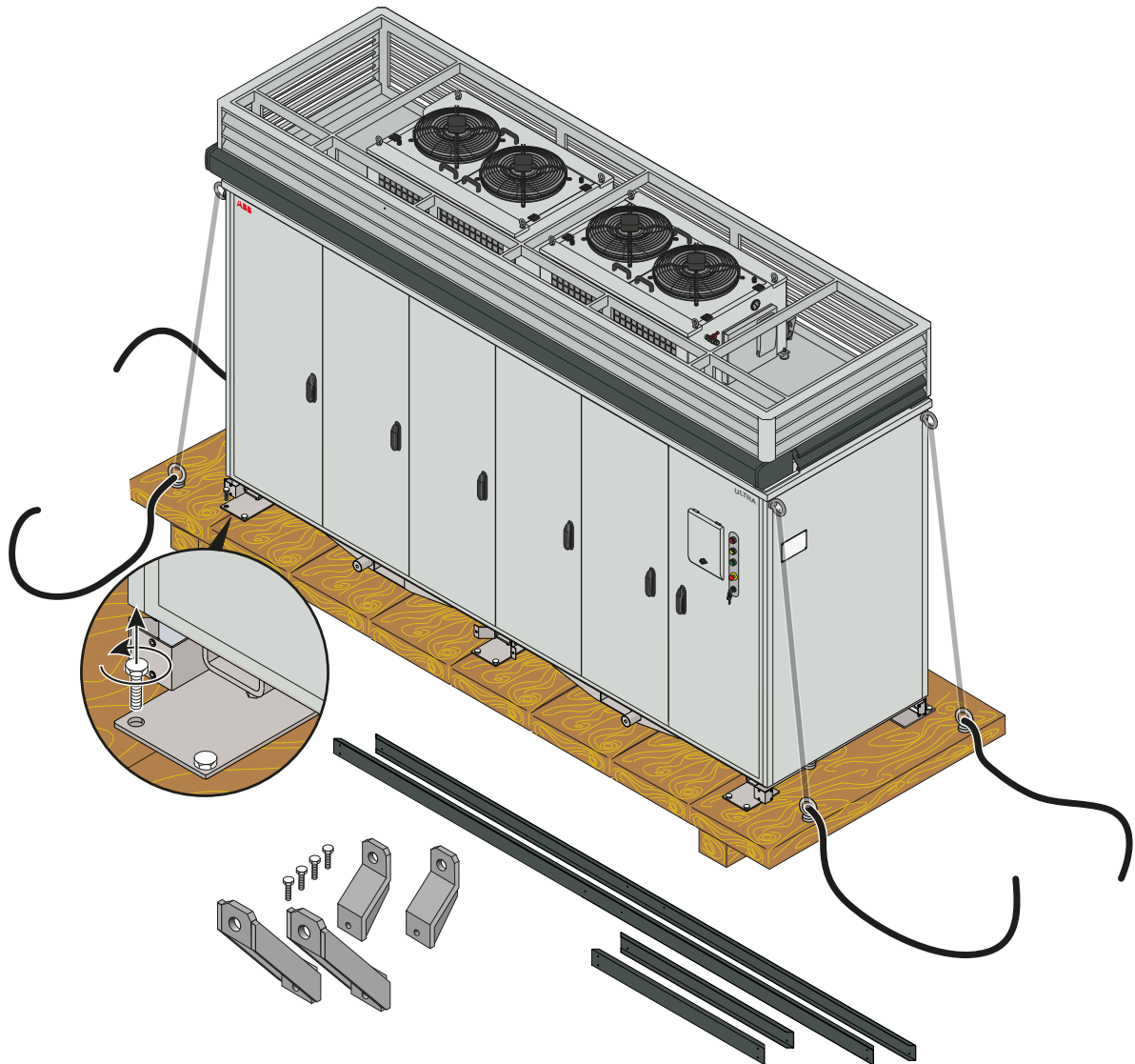

	ULTRA 700 kW	ULTRA 1050 kW	ULTRA 1400 kW
Weight without packaging in kg	~ 3.000	~ 3.800	~ 4.600

The considerations discussed for the case of lifting with packaging apply for lifting operations without package too. In addition, the inverter must be lifted while observing the following conditions:

In case of lifting using cables provided with suitable fork balance for vertical pull or fork-lift trucks, take hold on the front longitudinal side by inserting the forks in the appropriate forklift slots (05).

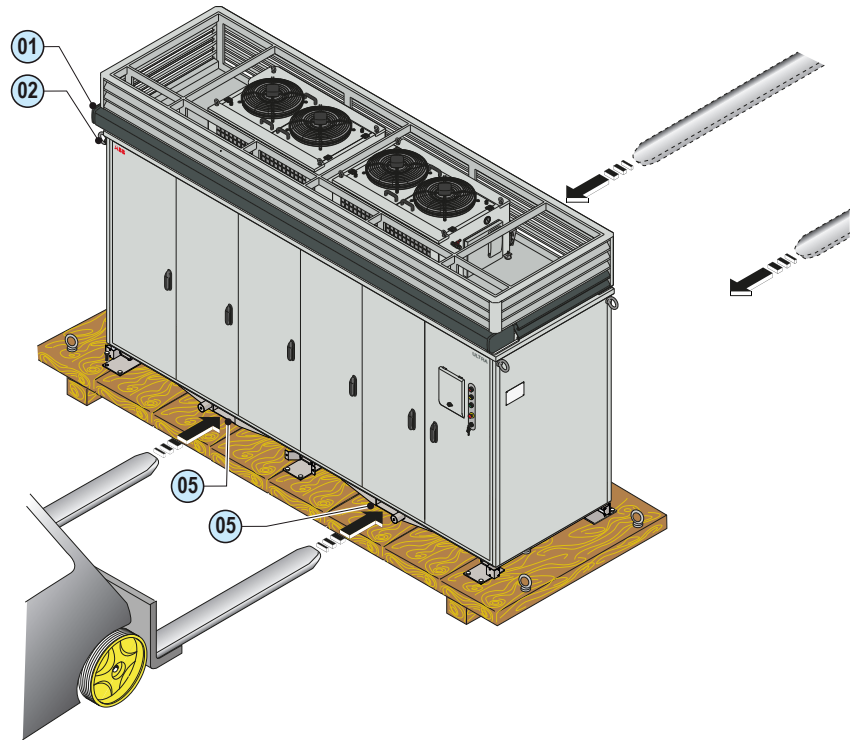

In case of direct lifting with cables or chains, the supplied special brackets must be employed by mounting them on the bars alongside the forklift slots (05) using **M24** screws.



The front and rear brackets are not identical and, if correctly placed, can prevent any possible interference with the protective awning (01) and allow to target the centre of mass.

- the front brackets (06) must be mounted on the front
- the rear brackets (07) must be mounted on the rear





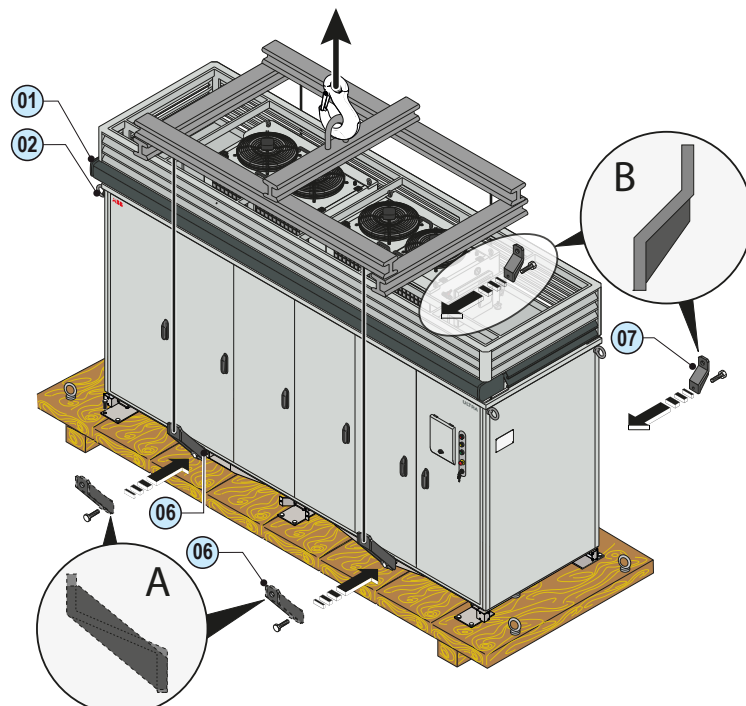



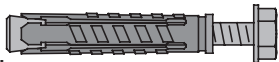

It is strictly **FORBIDDEN** to lift the inverter by the eyebolts (02).

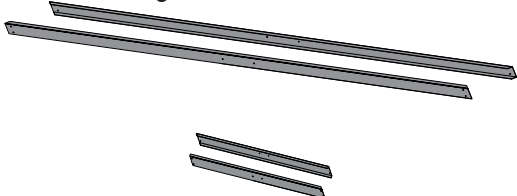

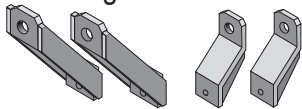
List of components supplied

Table: Components supplied with the equipment

Description of the equipment	ULTRA 700 kW Quantity	ULTRA 1050 kW Quantity	ULTRA 1400 kW Quantity
WALL PLUG (with screw and washer) for mounting to the base. Type: galvanised SLM M16x100 	8	12	12
COVER for M24 holes to replace the eyebolts  in the top part of the structure Front / rear / right / left CASING 		4	
Casing mounting SCREWS  *pre-installed on the inverter	16	20	20
Front and rear lifting brackets 		2+2	
Lifting brackets mounting screws  *pre-installed on the inverter		4	
KEYS for the front doors + display door key + key for the On/Off switch 	8 + 2 + 1	10 + 2 + 1	12 + 2 + 1
Boxes containing the Roxtec cable gland modules + lubricator dispenser 	9 + 6	11 + 6	11 + 6
USER manual and installer maintenance CD-ROM with technical documentation 		1 + 1	





General conditions

Installation of the equipment is carried out based on the system and the place in which the equipment is installed; therefore, its performance depends on the correctness of the connections.

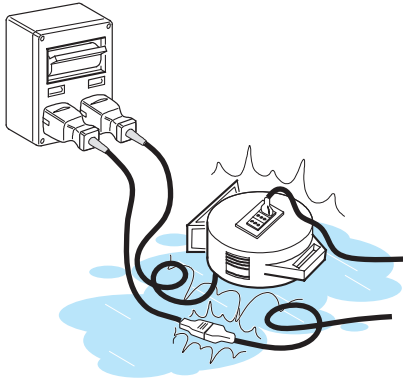

Staff authorised to carry out the installation must be specialised and experienced in this job; they must also have received suitable training on equipment of this type.

The operation must be carried out by specialised staff; it is in any case advisable to comply with what is written in this manual and adhere to the diagrams and attached documentation.



For Safety reason only a qualified electrician, who has received training and / or has demonstrated skills and knowledge in construction and in operation of this unit, can install this inverter.



The installation is done by qualified installers and/or licensed electrician according to the applicable local code regulations



The connection of an inverter energy system to an electrical installation connected to the electricity distribution network shall be approved by the appropriate electrical distributor.



The installation must be carried out with the equipment disconnected from the grid and from the photovoltaic generator.



When the photovoltaic panels are exposed to light, these supplies a direct current voltage to the inverter.



The installation must be carried out with the equipment disconnected from the grid (power disconnect switch open) and with the photovoltaic panels shaded or isolated.

Environmental checks

- Consult the technical data to check the required environmental conditions (protection rating, temperature, humidity, altitude, etc.)
- Do not install in locations that may be subject to flammable substances or gases may be present
- Place the inverter in a location easily accessed by the operators.
- Avoid installing the inverter in locations that may be subject to rainwater accumulation
- If the ambient temperature is lower than 50°C, it is not necessary to protect the inverter from direct sunlight irradiation. For higher temperatures, it is necessary to protect the inverter from direct sunlight irradiation to avoid any output power derating. In any case, the ambient temperature should be within the range of working temperatures of the inverter indicated in the technical characteristics.
- In case of installation in closed environments, ensure good ventilation using for instance specifically dedicated systems.
- Avoid interference by electromagnetic sources that may jeopardise the correct operation of electronic equipment, with consequent hazards;



The final installation of the inverter should not prevent access to any outside disconnection means.

Refer to the warranty conditions to evaluate the possible exclusions from warranty related to improper installation.

Installations above 2000 metres

On account of the rarefaction of the air (at high altitudes), particular conditions may occur that should be considered when choosing the place of installation:



- Less efficient cooling and therefore a greater likelihood of the device going into derating because of high internal temperatures.
 - Reduction in the dielectric resistance of the air that, in the presence of high operating voltages (DC input), can create electric arcs (discharges) that can reach the point of damaging the inverter.
- As the altitude increases, the failure rate of some electronic components increases exponentially because of cosmic radiation.



All installations at altitudes of over 1000 metres must be assessed case by case considering the aforesaid criticalities.

Installation position

When choosing the place of installation, observe the following conditions:

- Install the inverter on a strong base adequate to support its weight.
- Install in safe, easy to reach locations
- Install in a perfectly vertical position by using suitable verification instruments.



Installing the inverter on a base which is not sturdy and level may cause risks of fall and/or damage to the inverter.

- Maintenance/installation operations on the equipment hardware and software are mainly performed via front access.



It is good practice to ensure all sides are accessible, so as to facilitate any possible maintenance operations.

- Comply with the indicated minimum distances. Distances vary depending on whether a ABB hot air outlet hood is used.



In case of multiple inverter installations, the minimum distances must be observed for each individual unit .



For models with grounding kits, the installation of the inverter and arrays affixed to it must be performed in an area accessible only to qualified personnel, by opening doors or by unlocking barriers. This area must be clearly marked with appropriate warning signs.

- Maintenance/installation of the equipment hardware and software can be performed by opening the front doors or removing the rear panels. Check that the correct installation safety distances are observed in order to allow routine check and maintenance operations.

- Observe the minimum distance requirements. In case more inverters are installed, minimum distances must be observed for each individual unit.

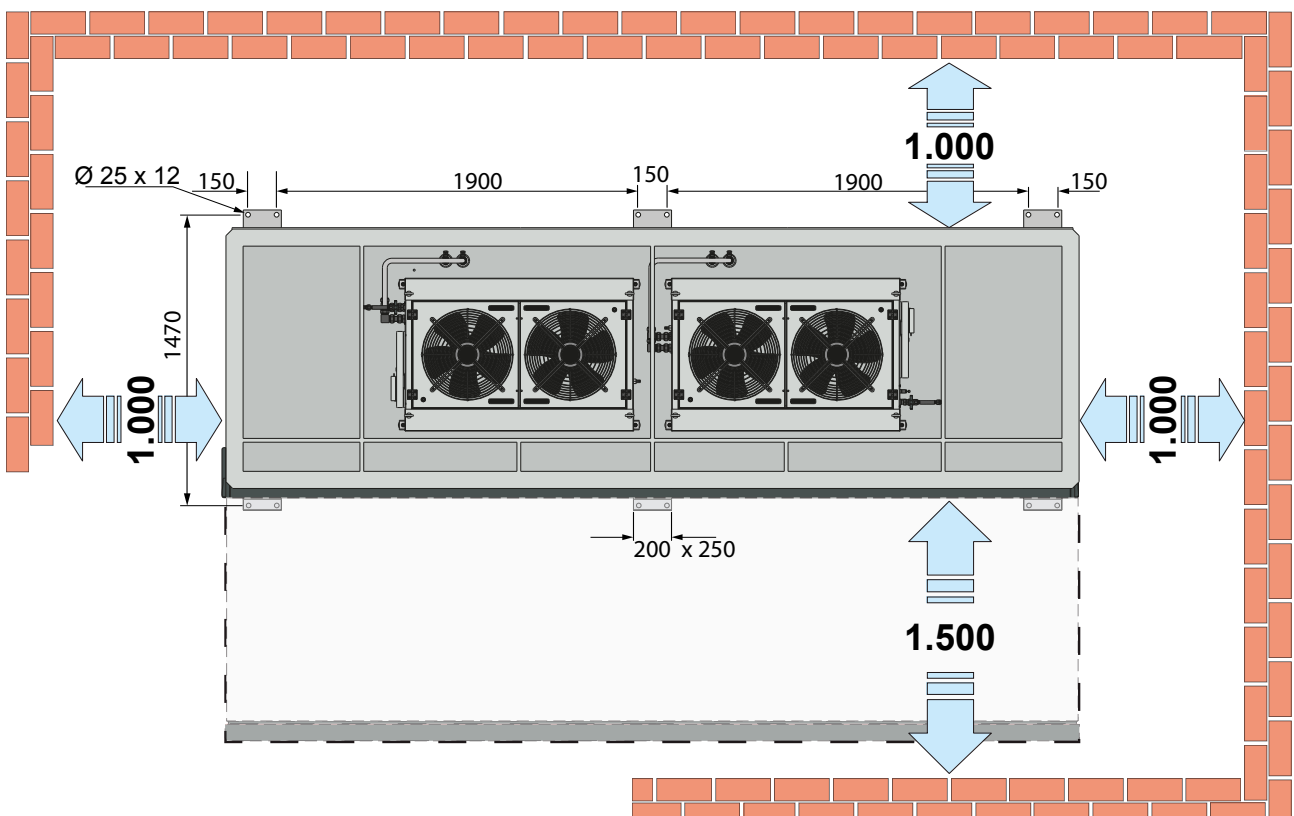

Preparation and requirements of the base

For optimum installation, the inverter must be secured with support feet ④ to a base made of an adequate material capable of supporting the weight.

The base must be level (maximum allowable slope 0.3%) and have dimensions specified at the bottom of the inverter model.

As a general guideline, ABB recommends to build a base ④ with the following characteristics:

- Central bay protected by a walkable grid flooring ③ for easy cable feeding and routing
- Sidewall holes ② to feed the DC, AC and communication and control signals corrugated pipes

Avoid using the corrugated pipes already used for DC or AC conductors for the communication and signal cables too!

Upon request, ABB offers its customers the drawings of a base that is compatible with the inverter installation.

- Holes for rainwater drainage ①
- Central bay with sloped bed to channel the rainwater into the drainage holes

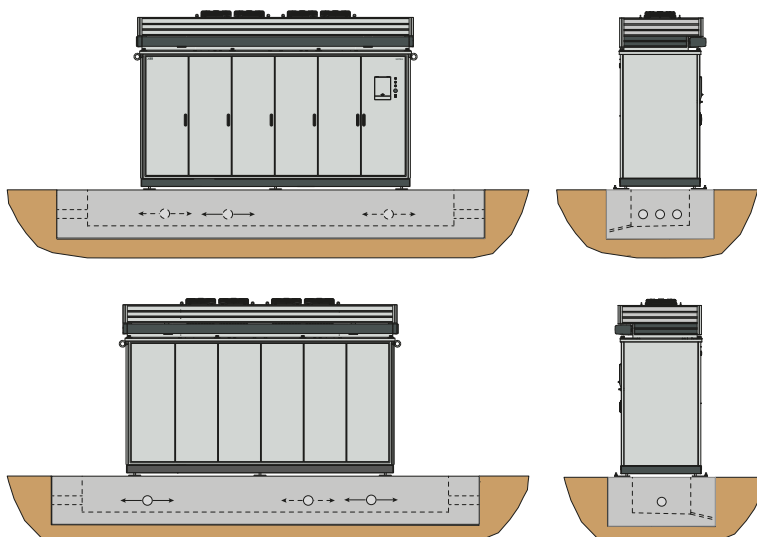
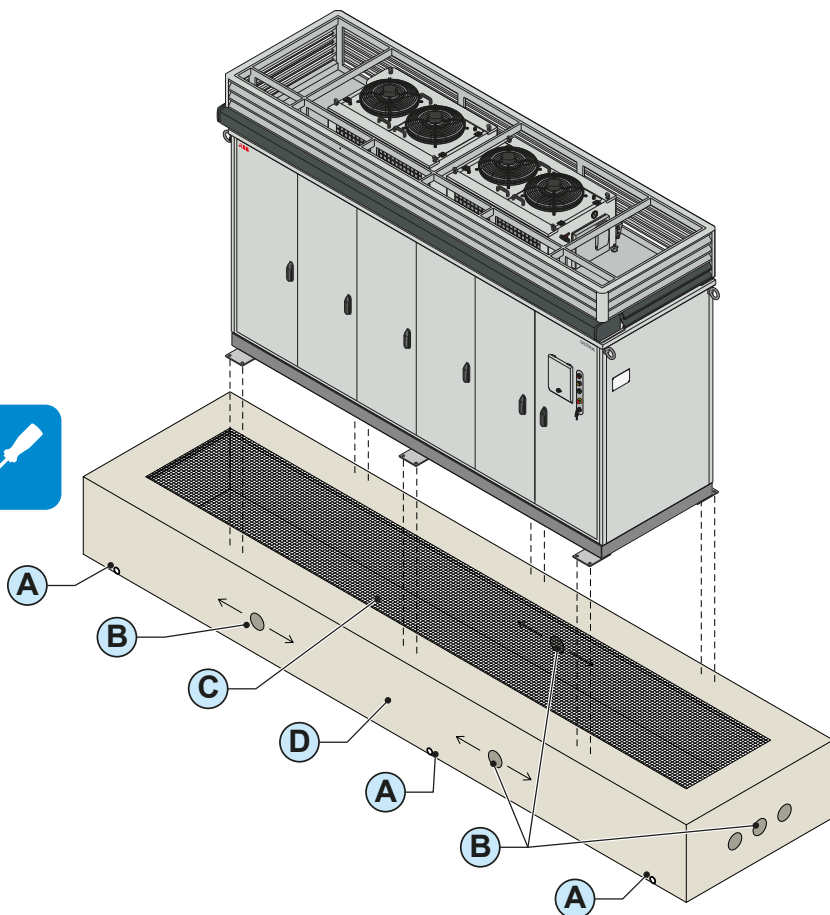

Here on the side are the 4 side views of the base.

The cable feeding holes serve solely as rough guidance, as their number, size and position depend on the used cable type and on the system configuration (E.g.: cable feeding side).

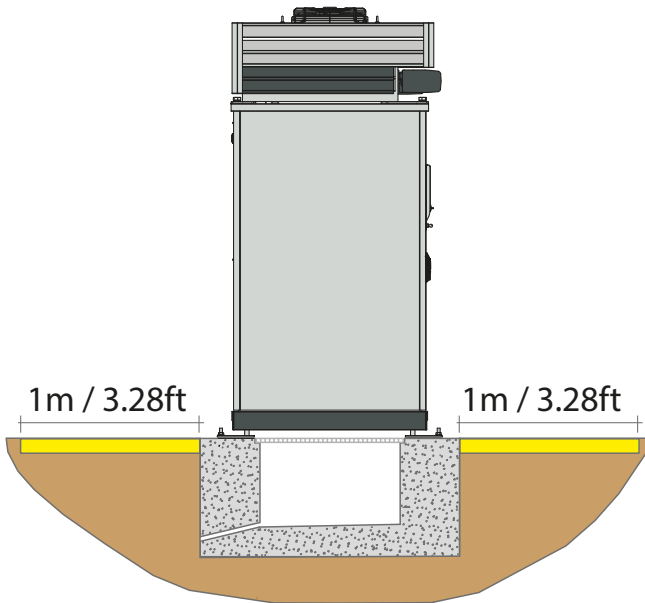

Further to the base, it is also recommended to install a walkable flooring extended for at least 1 metre around the inverter. This allows to work on a clean and sound surface while performing installation and maintenance operations.

As per the ABB guideline, the inverter-base assembly is designed for installation on any kind of floor. According to the calculations, the base must be made of reinforced concrete with the following composition:

Steel

The structural steel must be factory-tested B450C-type, with tensile strength of 2600 kg / cm sq. both for the longitudinal rebars and the brackets.

Aggregate

The following table shows the size and percentage of the natural or crushed aggregate to be used:

Material	Size	Percentage
Crushed (or alluvial) sand	0 - 5 mm	40%
Coarse gravel	5 - 12 mm	35%
	12 - 20 mm	25%

Binding agents

“Portland 425” binding agents must be used, at a concentration of 3.5 q / m³ of concrete.

Concrete cover

The concrete layer that covers the reinforcement steel (cover) must be at least 2 cm thick for the case of slabs or walls, or 2.5 centimetres for beams and pillars

Below is a list of the base dimensions and the heights for the placement of the corrugated pipes to feed the conductors inside the inverter:



ULTRA-700 base dimensions

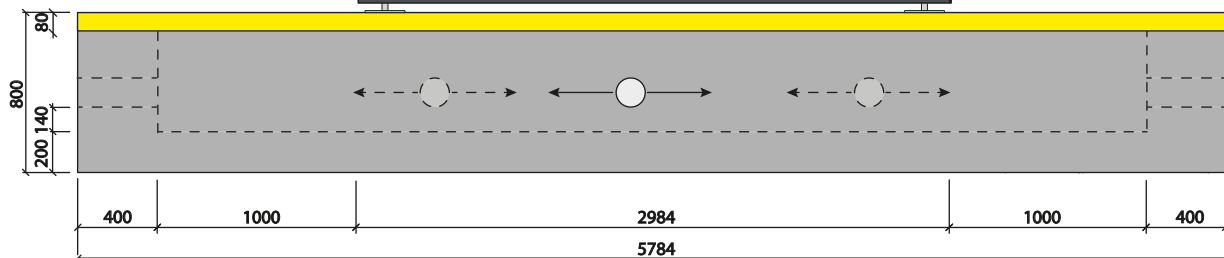
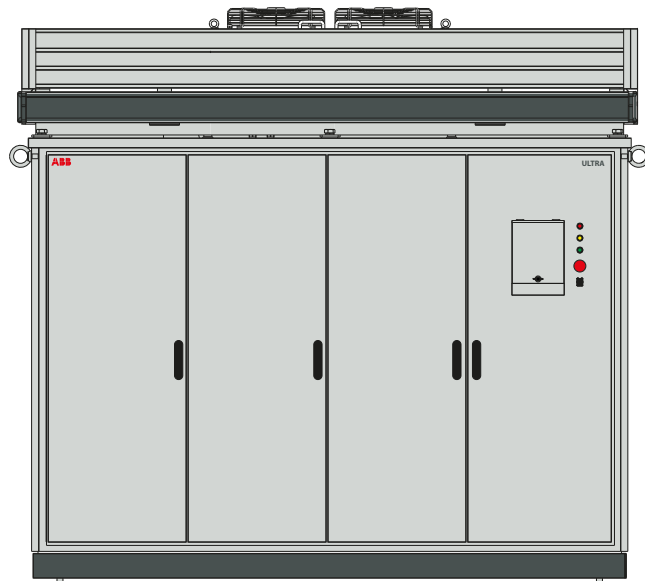
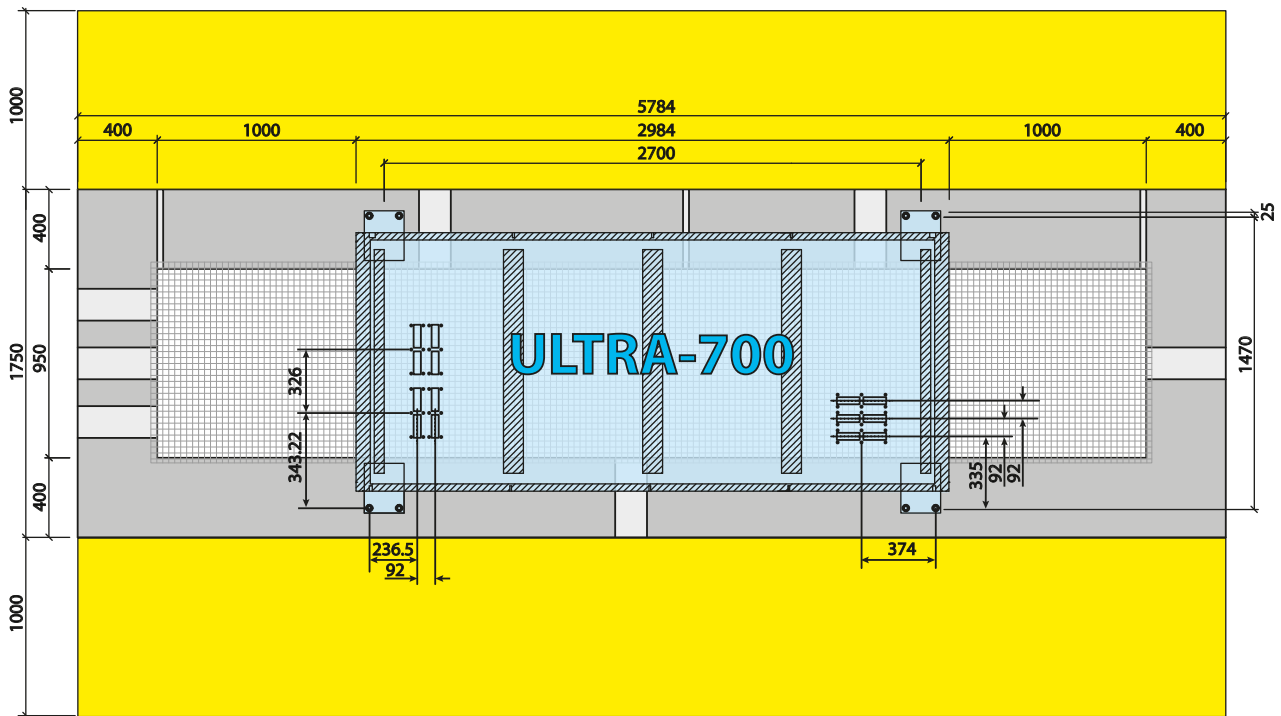

The walkable flooring is highlighted in yellow. It allows to work on a clean and sound surface while performing installation and maintenance operations.

ULTRA-1050 base dimensions

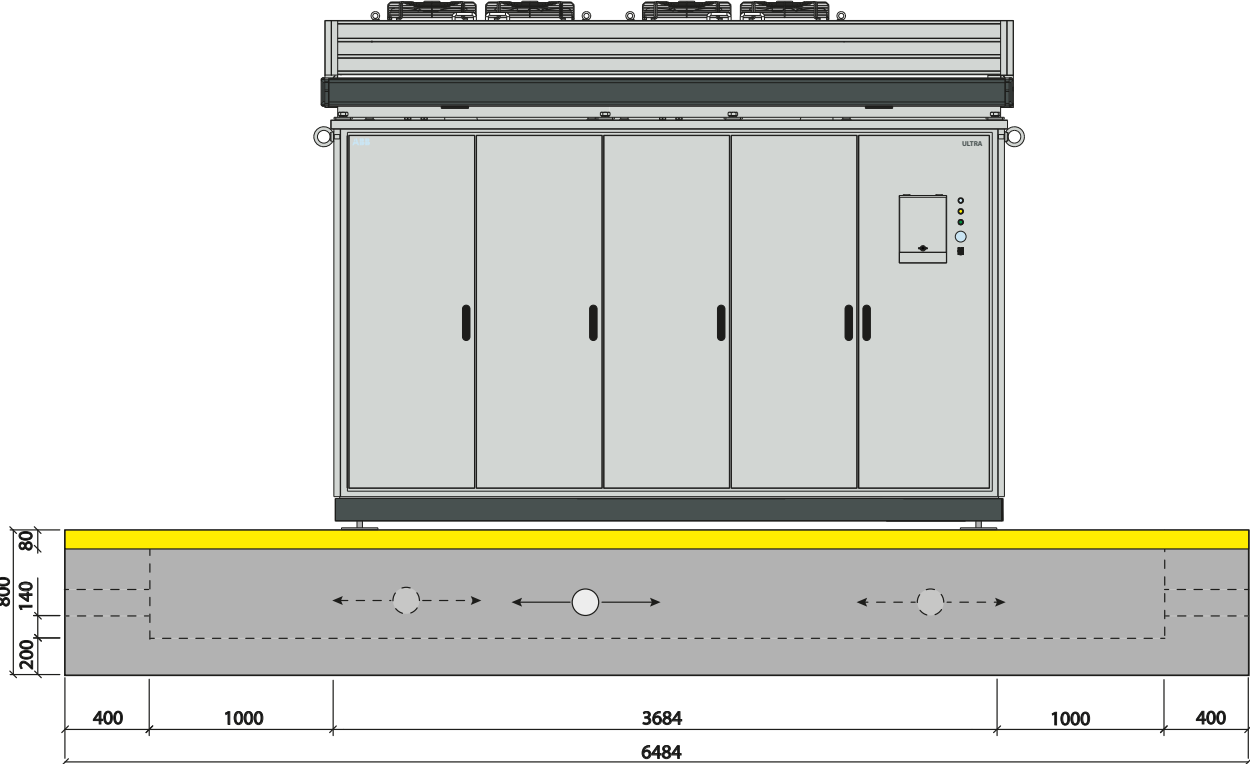
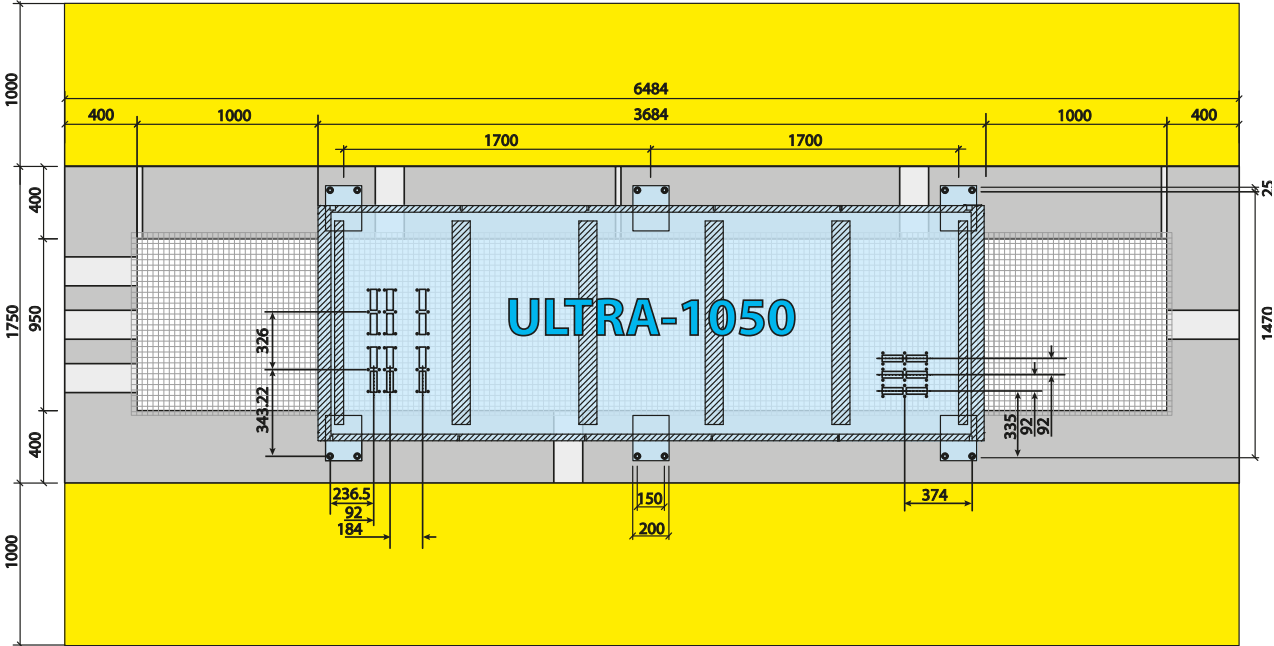

The walkable flooring is highlighted in yellow. It allows to work on a clean and sound surface while performing installation and maintenance operations.

ULTRA-1400 base dimensions

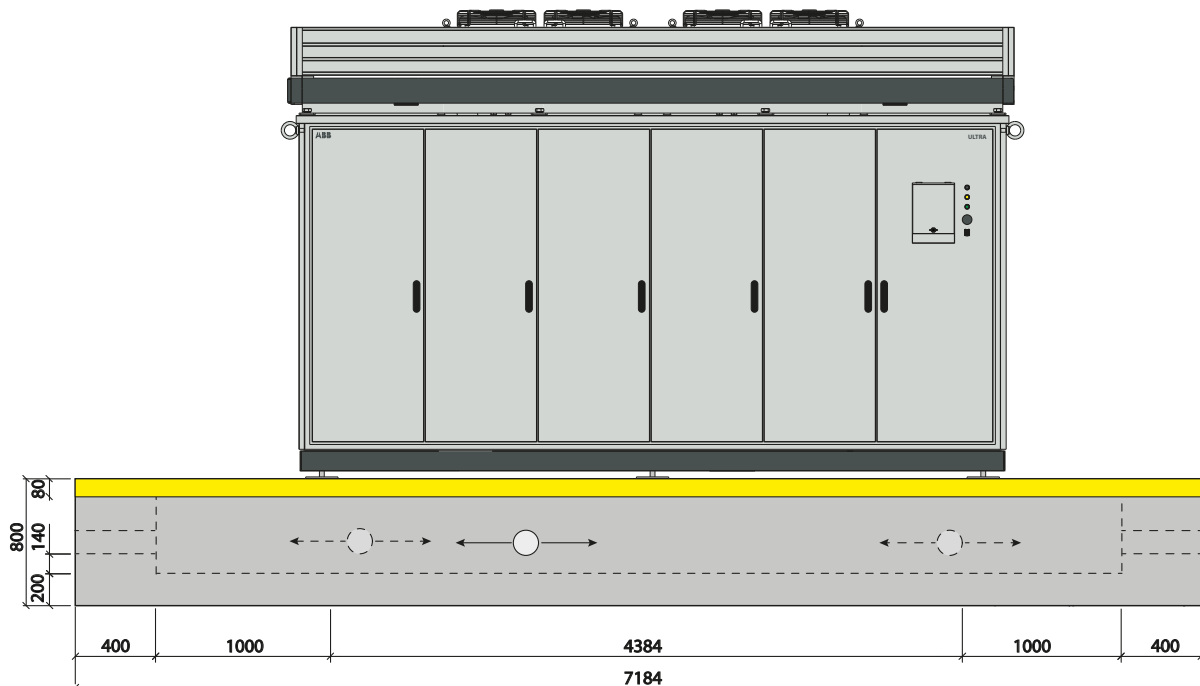
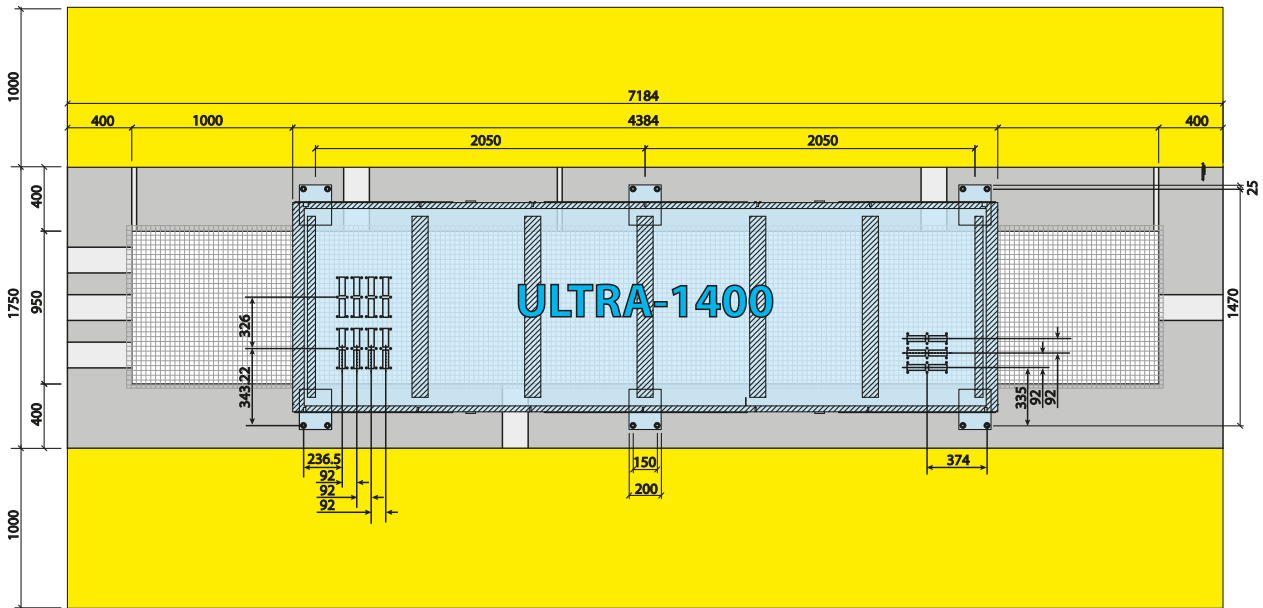

The walkable flooring is highlighted in yellow. It allows to work on a clean and sound surface while performing installation and maintenance operations.

Location and mounting on the base

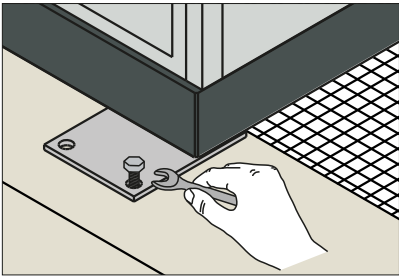

Lift the inverter following the instructions in the relevant chapter and place it above the base. The holes previously prepared on the base must be aligned with the holes on the support feet 04.

The feet must be mounted on the base using the suitable wall plugs, screws and washers supplied. Alternatively, it is possible to use chemical resin and an adequately dimensioned guy rope.

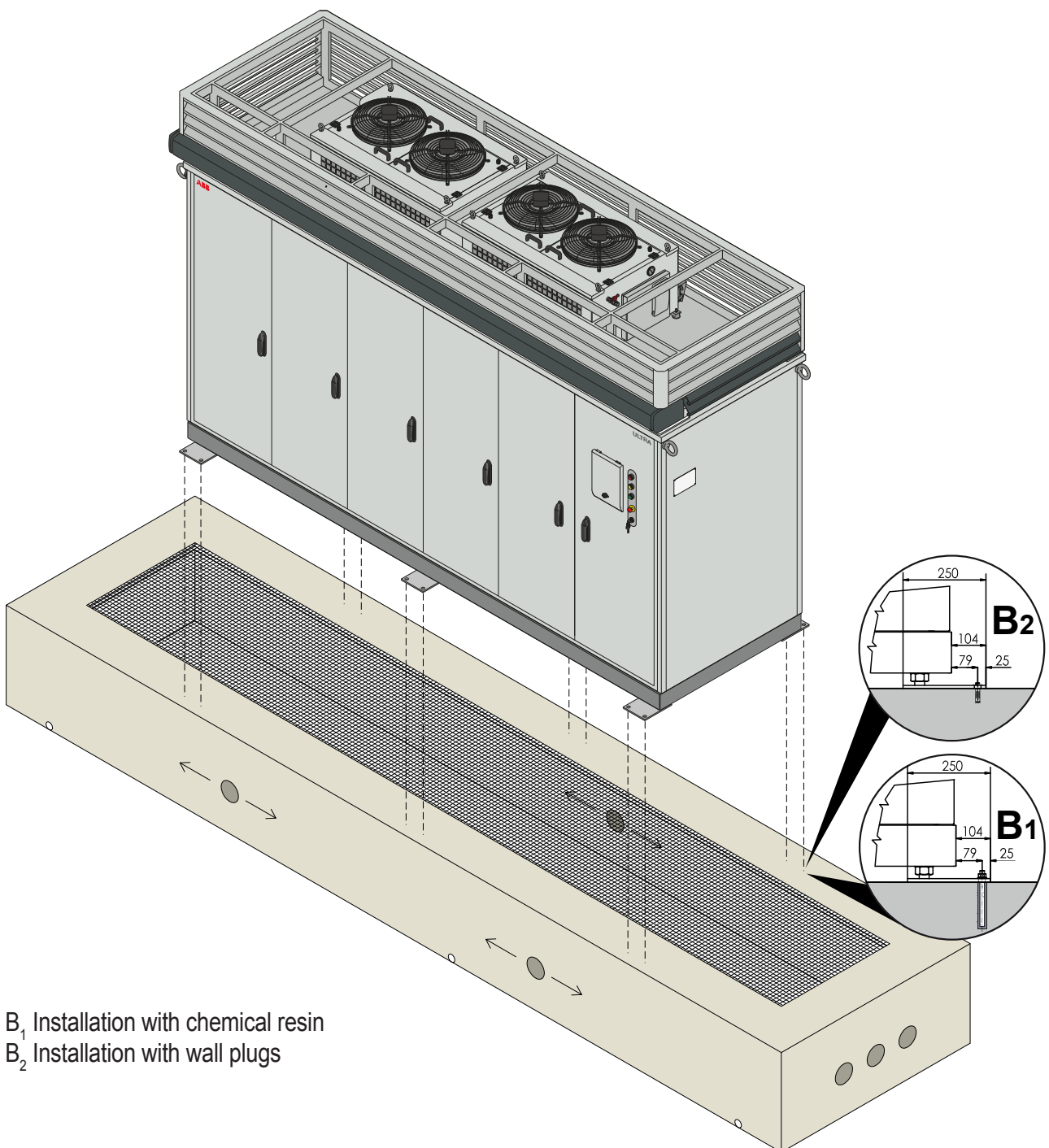

B₁ Installation with chemical resin

B₂ Installation with wall plugs

000084CG

Operations to be performed after mounting

Once the inverter is mounted on the base, it is possible to complete the installation of the mechanical parts.

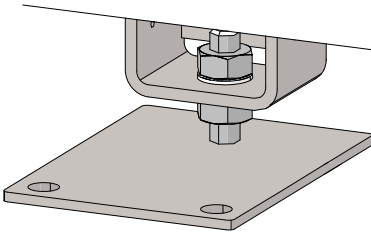

If it is necessary to compensate for any slight unevenness caused by a base that is not perfectly level, the height can be adjusted by setting the two nuts on the support feet ④.

Remove the front brackets ⑥ and the rear brackets ⑦ used for lifting and store them in a safe place for any future displacement of the inverter.

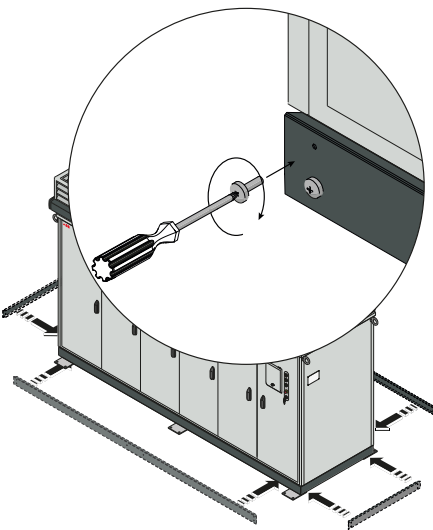

Install the 4 lower casings using the supplied dedicated screws (pre-installed on the inverter). They must be aligned with the supports in proximity of the support feet ④.

Operations preparatory to electrical connections

Before carrying out any electrical connection, the following checks must be performed:

Checks outside the inverter

- Check that the grid voltage is physically disconnected outside (upstream) the inverter
- Check that the auxiliary voltage is physically disconnected outside (upstream) the inverter
- Check that the DC inputs are physically disconnected outside (upstream) the inverter (PVI-STRINGCOMB)

Internal inverter checks

- Check that every DC disconnect switch ④ installed on each conversion compartment ⑩ is open
- Check that the AC disconnect switch ⑦ installed on the AC and user interface compartment ⑪ is open
- Check that the general auxiliary voltage disconnect switch located on the auxiliary panel ③ is open



*Ensure that voltages are not present on AC or DC conductors.
Ensure that there is no possibility of accidentally resetting the disconnect device.*

Operations preparatory to PV generator connection

Checking the correct polarity of the strings

Using a voltmeter, check that the voltage of each string observes the correct polarity and falls within the input voltage limits accepted by the inverter (see technical data).



Inversion polarity can cause serious damage

If the voltage without load of the string is near the maximum value accepted by the inverter, it must be borne in mind that with low ambient temperatures the string voltage tends to increase (in a different way according to the photovoltaic module used). In this case, it is necessary to carry out a check of the sizing of the system and/or a check on the connections of the modules of the system (e.g.: number of modules in series higher than the design number).

Checking of leakage to ground of the photovoltaic generator



Measure the voltage present between positive and negative pole of each string with respect to ground.

If a voltage is measured between an input pole and ground, it may be that there is a low insulation resistance of the photovoltaic generator and the installer will have to carry out a check to solve the problem.



Do not connect the strings if a leakage to ground has been found because the inverter might not connect to the grid.

Connections to the DC input compartment (6/8-input versions)

The DC input compartment ⑨ is divided into 3 main areas dedicated to:

1. feeding the cables
2. connecting the cables
3. housing the input fuses

Below is a list of operations required for the proper installation of the input cables so as to ensure that the IP protection rating of the inverter is preserved.

Opening and accessing the DC connections zone

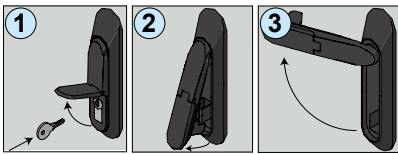

The front door of the DC input compartment ⑨ uses a handle with locking system (supplied). To access the DC input compartment ⑨ insert and turn the key until it clicks, then lift and rotate the handle.

Once the door is open, the Plexiglas safety cover plates must be removed (DC fuses cover plate ⑳ and DC bus bars cover plate ㉑) to access the internal components.

The cover plates are secured to the frame with the latches ㉒. Lift all the latch levers to unlock the panel, then remove it by lifting it slightly upwards and then pulling it.

The upper panel protecting the DC input protection fuses ㉓ has 4 latches, while the lower panel protecting the DC input bars ㉔ has only 2 (the lower part is locked into two guides, pay attention during removal).

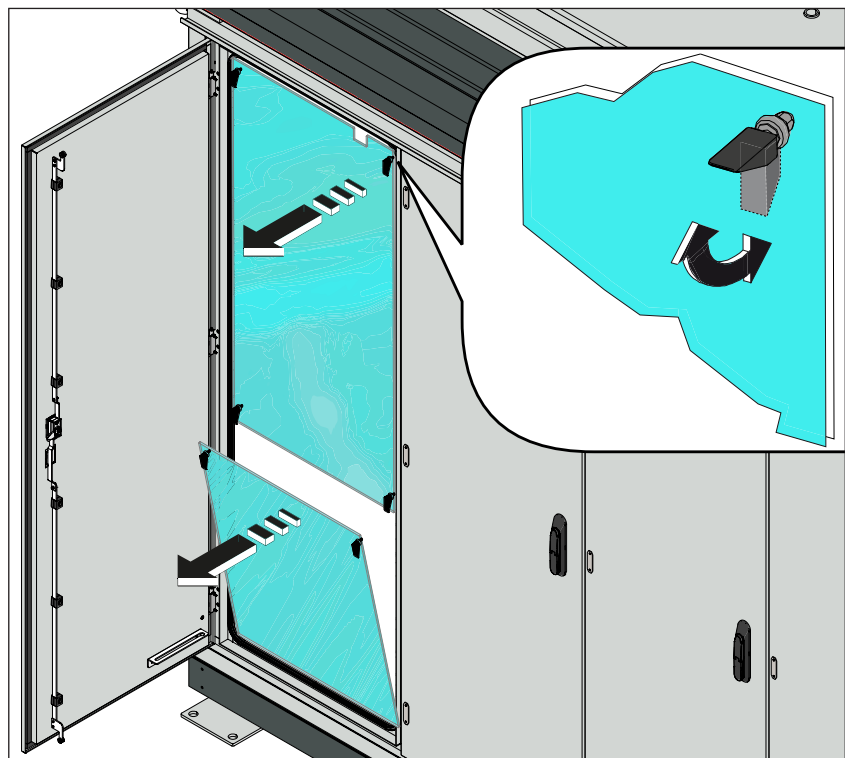

Feeding the DC cables inside the inverter.

The cables coming from the photovoltaic generator must be fitted into the frames of the DC cable glands ⁽²³⁾ following the numerical and alphabetical order shown in the figures below.

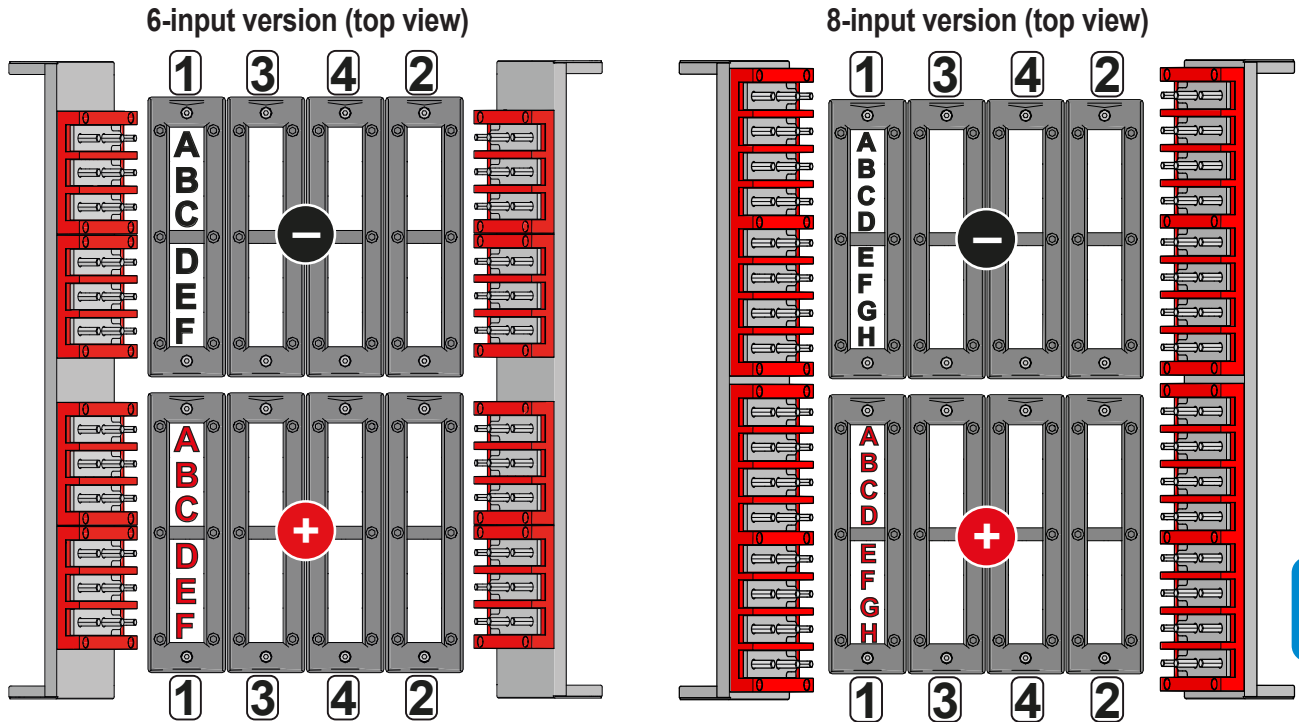

It is recommended to complete the installation of all cables belonging to a single module before proceeding to the next module, in order not to deal with a large number of cables to be connected inside the DC input compartment ⁽⁰⁹⁾. During this step, follow the numerical order (relative to the conversion module ⁽⁴³⁾).

The number of DC cable glands ⁽²³⁾ supplied with the 700 kW and 1050 kW versions is lower (based on the number of conversion modules):

ULTRA-700.0-TL only blocks 1 and 2 supplied

ULTRA-1050.0-TL only blocks 1,2 and 3 supplied

Preparation of the DC cables

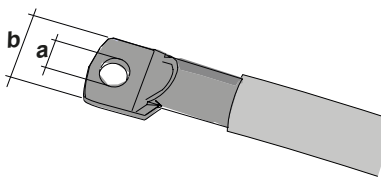

To prepare the DC cables it is necessary to cut each of them to a sufficient length to reach the appropriate DC input bar ⁽²⁴⁾ and to fit the cable lugs used to secure the cables.

The cable lugs must meet the following dimension requirements:

a = 11 mm (min)

b = 30 mm (max)



All the connection bars internal to the inverter are made of copper. If aluminium cables are used, proper coupling with the copper bars must be ensured by using adequate bimetallic cable lugs.

Installation of DC cable glands

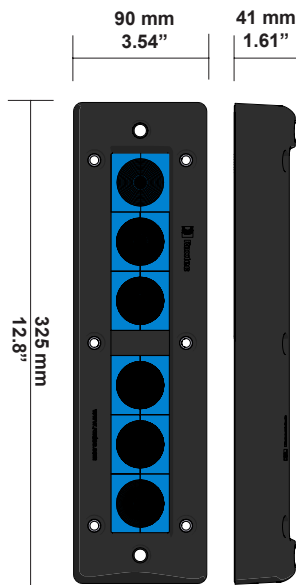

Special cable glands are supplied with the inverter which guarantee installations in compliance with the expected IP protection rating.

DC input compartment, 6-input version:

Model: EzEntry 24/6

Number of cables accepted 6

Diameter of accepted cables/pipes: 0+9.5-32.5 mm / 0+0.374-1.280"

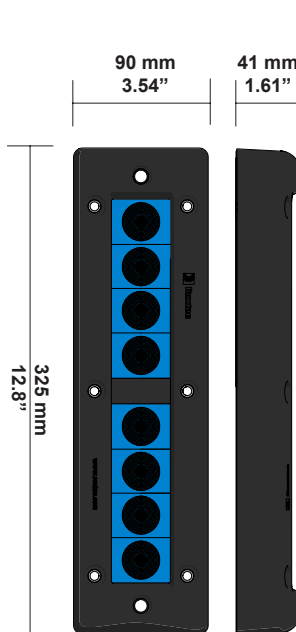

DC input compartment, 8-input version:

Model: EzEntry 24/8

Number of cables accepted 8

Diameter of accepted cables/pipes: 0+10-25.0 mm / 0+0.394-0.984"

The DC cable gland kit ⁽²³⁾ is composed of:

- a frame (pre-installed on the inverter)
- the modules, the lubricant and the mounting accessories (supplied in special boxes inside the inverter).

The only tools necessary are the Allen keys included in the kit.



Installations carried out without using the supplied cable glands do not guarantee that the structure will maintain the IP protection rating planned by the manufacturer.

Installation procedure for individual DC cable glands:

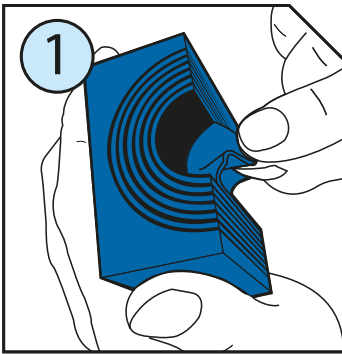

- Adapt the module to the cable by unfolding the removable layers until an internal diameter suitable to house the cable is reached.

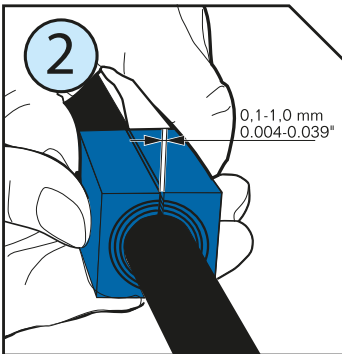

- In order to guarantee adequate tightness, the maximum space between the two halves of the module, pressed against the cable, must be within 0.1 and 1.0 mm.

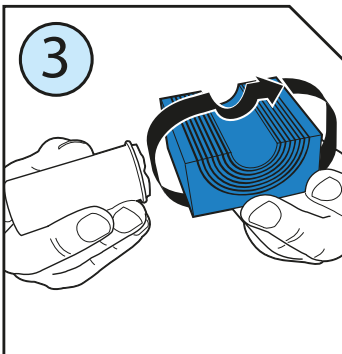

- Carefully lubricate all modules before installation, on both the internal and external surfaces.

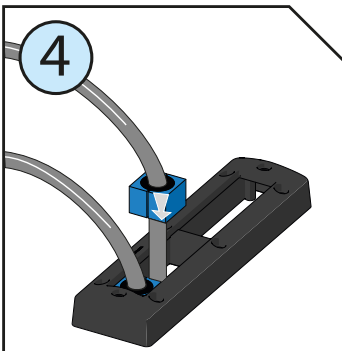

- Insert the modules as per the installation drawing.

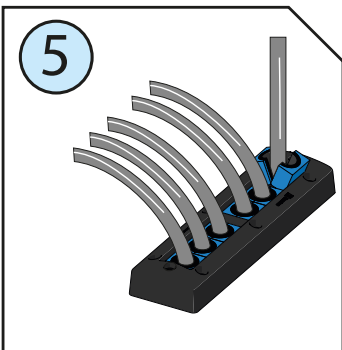

- In order to simplify the insertion of the last module, tilt half of the modules and push them into the frame simultaneously.

Installation of cables on the DC input bar

Ensure all checks preliminary to the connection of the strings have been performed (check for correct polarity and absence of any leakage to ground). Proceed then to install the cables on the DC input bars ⁽²⁴⁾.

6-input version: each bar is composed of 6 positive inputs (placed in the first 6 positions of the bar) and 6 negative inputs (placed in the next 6 positions of the bar)

The cable lug must be mounted on the corresponding input on the bar as shown in the drawing.

- 1 = Cable lug
- 2 = Flat washer
- 3 = Grower (split ring) washer
- 4 = Nut

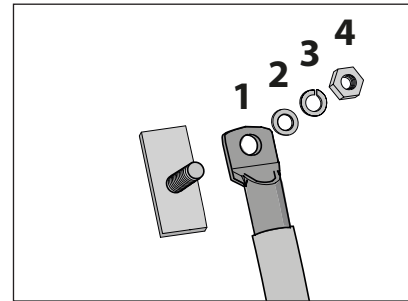

8-input version: each bar is composed of 8 positive inputs (placed in the first 8 positions of the bar) and 8 negative inputs (placed in the next 8 positions of the bar)

The cable lug must be mounted on the corresponding input on the bar as shown in the drawing.

- 1 = Cable lug
- 2 = Flat washer
- 3 = Grower (split ring) washer
- 4 = Nut

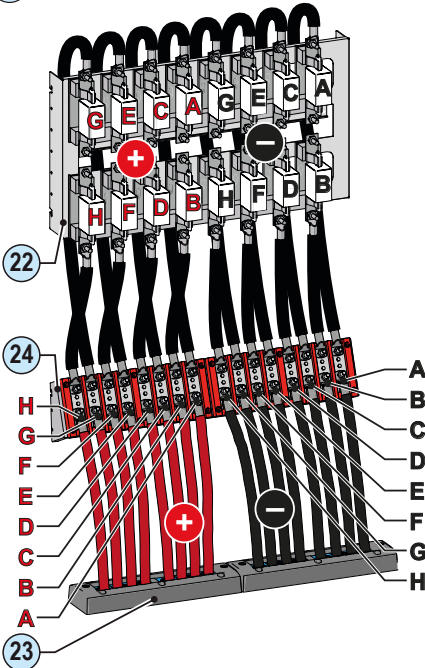
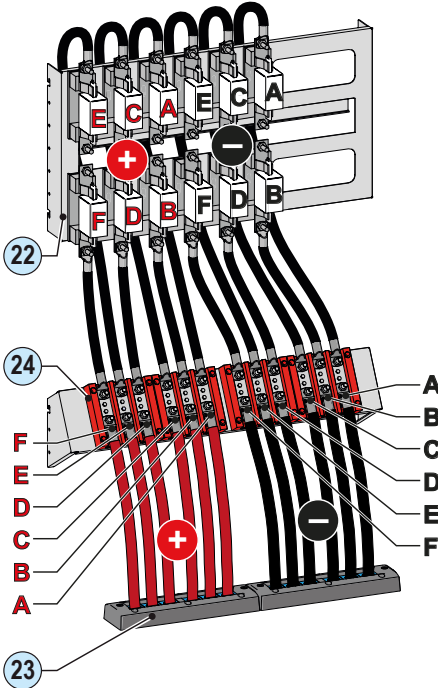
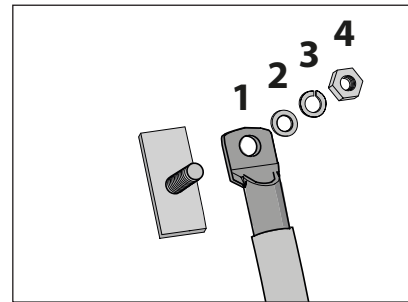

The cable lugs must be installed with an adequate tightening torque (see technical data)



Ensure that all contact surfaces are not oxidised in order to even avoid overheating by contact!

If oxidation is observed, the contact must be cleaned using sandpaper.

Ensure that the range of cables and their lengths have been correctly dimensioned in order to avoid dangerous overheating!

Final operations

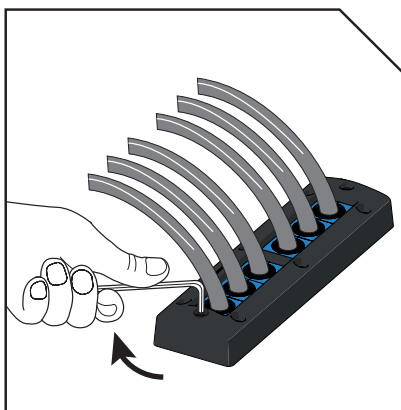

In order to preserve the inverter IP isolation rating, the two locking screws on each cable gland frame must be tightened using the supplied Allen key (5-7 Nm recommended torque). In this way the integrated compression system will secure the cables.



Once all the DC input cables are installed, the cover plates must be mounted again and locked in place using the latches ⁽²¹⁾, then the DC door must be closed.

Keys for opening must be kept in a place accessible to authorised installation and maintenance operators!



Connections to the AC and user interface compartment

The AC and user interface compartment ¹¹ is divided into 3 main areas dedicated to:

1. feeding the cables (AC output, auxiliary voltage, ground, communication and control signals) and connecting the AC and auxiliary cables
2. housing the AC fuses ⁶²
3. connecting the communication and control signals and the auxiliary devices.

Below is a list of operations required for the proper installation of the output cables so as to ensure that the IP protection rating of the inverter is preserved.

Opening and accessing the AC connections zone

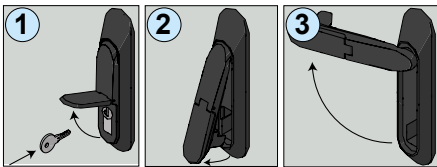

The front door of the AC and user interface compartment ¹¹ uses a handle with locking system (supplied). To access the AC and user interface compartment, insert and turn the key until it clicks, then lift and rotate the handle.

Once the door is open, the Plexiglas safety cover plates must be removed (AC fuses cover plate ⁷⁹ and AC bus bars cover plate ⁸⁰) to access the internal components.

The cover plates are secured to the frame with the latches ²¹. Lift all the latch levers to unlock the panel, then remove it by lifting it slightly upwards and then pulling it.

The upper panel for protecting the AC output protection fuses ⁶² has 4 latches, the lower panel for protecting the AC output bars ⁷³ has only 2 (the lower part is locked into two guides, pay attention during removal).

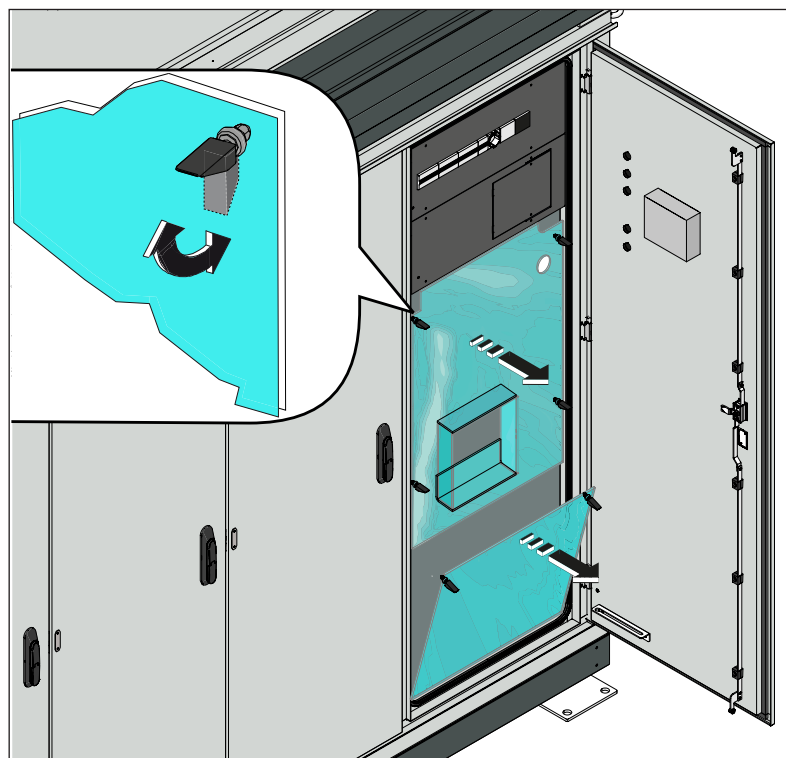

Feeding the AC cables inside the inverter



Before performing any operation, ensure that the AC output and auxiliary voltage disconnect switches (external) are open.

AC cable gland (top view)

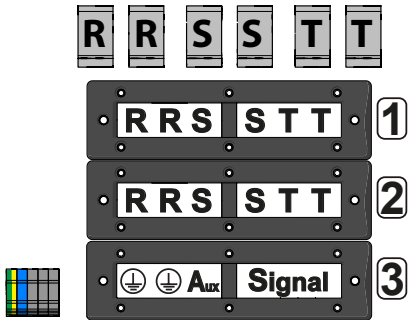

The AC output, ground, auxiliary voltage and communication and control signal cables must be fitted into the frames of the cable glands following the numerical and alphabetical order shown in the figure on the side:

R = R phase

S = S phase

T = T phase

⊕ = Ground

Aux = Auxiliary voltage

Signal = composed of 12 cable gland modules for communication and control signals

Preparation of the AC output, ground and auxiliary voltage cables



To prepare the AC and ground cables, it is necessary to cut each of them to a sufficient length to reach the appropriate AC output bar (73) or ground bar (76) and to fit the cable lugs used to secure the cables.

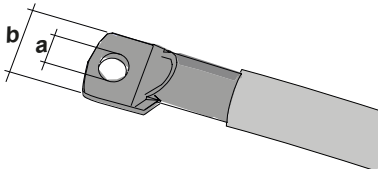

The AC output cable lugs must meet the following dimension requirements:

a = 13 mm (min)

b = 40 mm (max)

The ground cable lugs must meet the following dimension requirements:

a = 11 mm (min)

b = 30 mm (max)



All the connection bars internal to the inverter are made of copper. If aluminium cables are used, proper coupling with the copper bars must be ensured by using adequate bimetallic cable lugs.

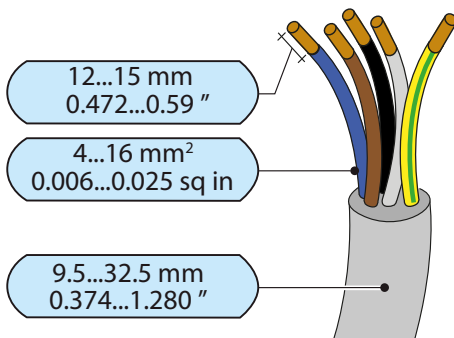

The connection of the auxiliary voltage requires a five-way cable (3 phases + neutral + ground).

The maximum diameter accepted by the cable gland is from 9.5 to 32.5 mm, while each terminal of the terminal block accepts a cable with cross-section which can vary from 0.6 up to 16 mm²

Installation of AC cable glands

Special cable glands are supplied with the inverter which guarantee installations in compliance with the expected IP protection rating.

The AC cable gland models ⁽⁷⁸⁾ used are **EzEntry 24/6** (power, ground and auxiliary cables) and **EzEntry 24/15** (cables used for the connections to the communication and control board ⁽⁶⁴⁾).

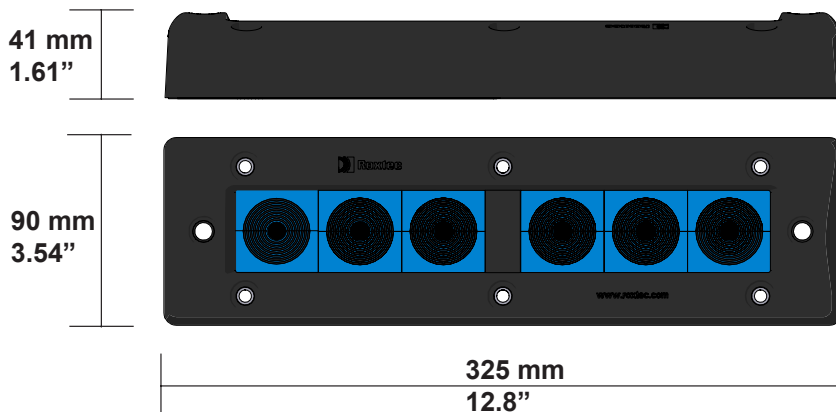

Model: EzEntry 24/6
Number of cables accepted 6
Diameter of accepted cables/ pipes: 0+9.5-32.5 mm / 0+0.374-1.280"

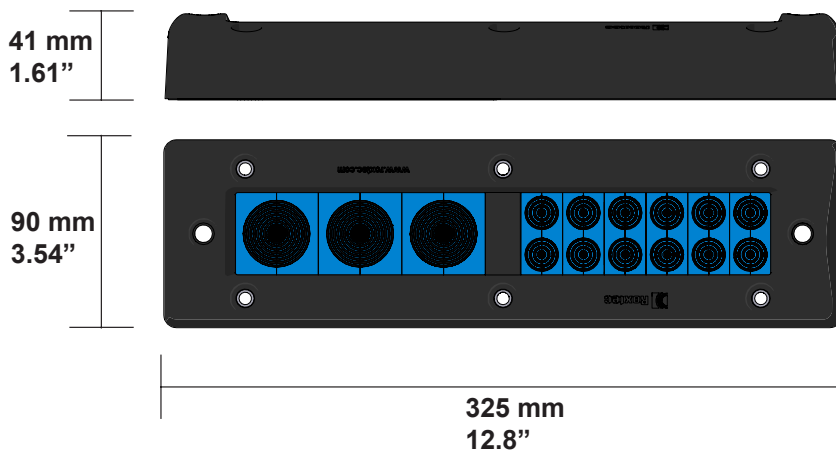

Model: EzEntry 24/15
Number of cables accepted 3 and 12
Diameter of accepted cables/ pipes:
 3-cable side: 0+9.5-32.5 mm / 0+0.374-1.280"
 12-cable side: 0+3.5-16.5 mm / 0+0.138-0.650"

The AC cable gland kit ⁽⁷⁸⁾ is composed of:

- a frame (pre-installed on the inverter)
- the modules, the lubricant and the mounting accessories (supplied in special boxes inside the inverter).

The only tools necessary are the Allen keys included in the kit.



Installations carried out without using the supplied cable glands do not guarantee that the structure will maintain the IP protection rating planned by the manufacturer.

Installation procedure for individual DC cable glands:

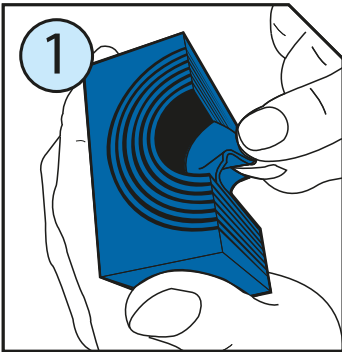

- Adapt the module to the cable by unfolding the removable layers until an internal diameter suitable to house the cable is reached.

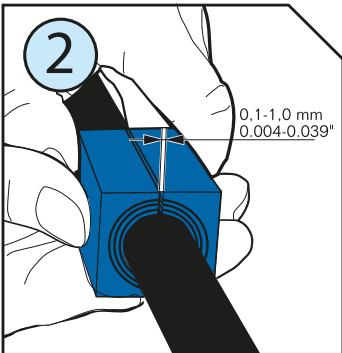

- In order to guarantee adequate tightness, the maximum space between the two halves of the module, pressed against the cable, must be within 0.1 and 1.0 mm.

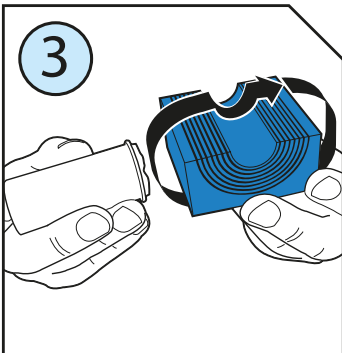

- Carefully lubricate all modules before installation, on both the internal and external surfaces.

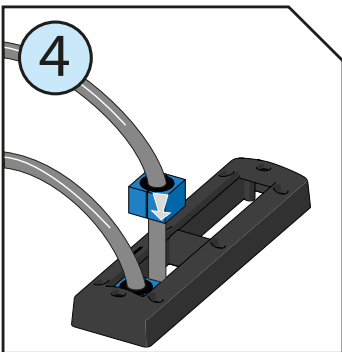

- Insert the modules as per the installation drawing.

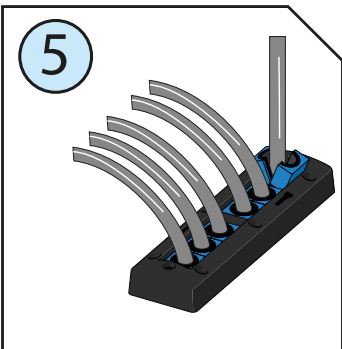

- In order to simplify the insertion of the last module, tilt half of the modules and push them into the frame simultaneously.



Connections of the ground conductors



Installation of the ground conductors on the ground bar ⁷⁶ is compulsory.

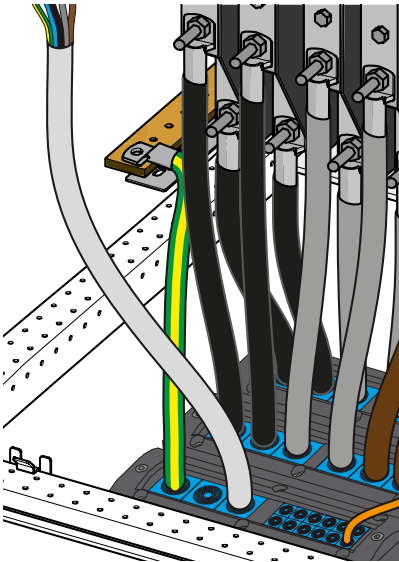

The grounding resistance of the system itself is crucial to the system's safety and must be established prior to the system first switch-on. The installer has the responsibility to provide the dimensioning of the ground conductors based on the characteristics of the inverter used and of the system in order to minimise the grounding resistance, in accordance with the existing legislation.

Conductors must be connected to the dedicated ground bar ⁷⁶ for the protective earthing (PE) of the equipment through the special AC cable glands ⁷⁸.

The cable lug must be mounted on the ground bar ⁷⁶ as shown in the drawing.

- 1 = Cable lug
- 2 = Flat washer
- 3 = Grower (split ring) washer
- 4 = Nut

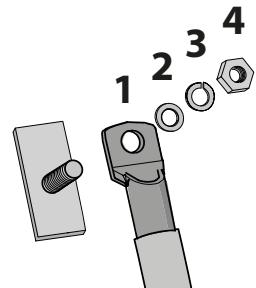

*The recommended minimum cross-section for the ground conductor is 120 mm².
The cable lugs must be installed with an adequate tightening torque (see technical data)*



All the connection bars internal to the inverter are made of copper. If aluminium cables are used, proper coupling with the copper bars must be ensured by using adequate bimetallic cable lugs.

Connection of the AC auxiliary line

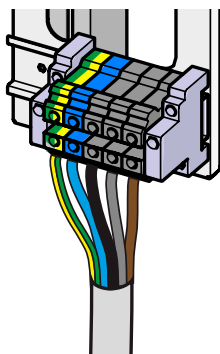

Install the auxiliary voltage line cable on the dedicated auxiliary connector ⁷⁵.

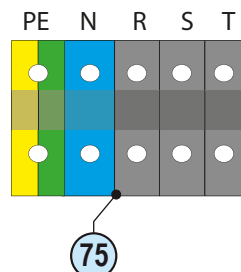

*The cable must be installed with the correct tightening torque (see technical data)
Be careful not to change round one of the phases with neutral!*

The conductor cross-section of the auxiliary line must be dimensioned so as to avoid undesired malfunctioning or overheating:

Connection of the output cables to the AC output bars



Ensure all checks preliminary to the connection of the strings have been performed (check for correct polarity and absence of any leakage to ground).

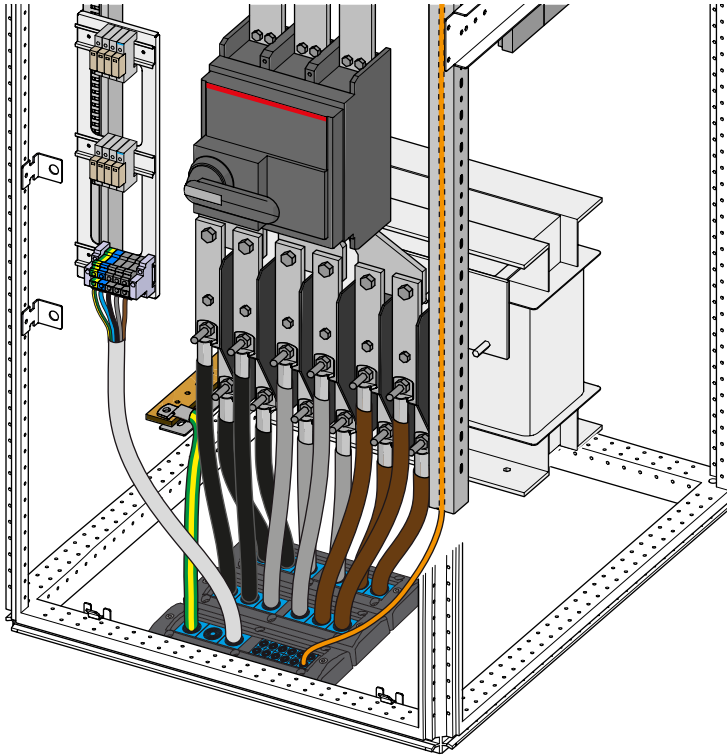

The output cables must be connected to the AC output bars ⁽⁷³⁾. For each output voltage phase two connection bars are available, which in turn allow the connection of two cables each.

The cable lugs must be mounted on the corresponding output bar as shown in the drawing.

- 1 = Cable lug
- 2 = Flat washer
- 3 = Grower (split ring) washer
- 4 = Nut

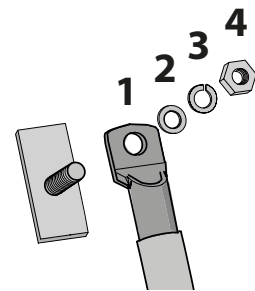

All the connection bars internal to the inverter are made of copper. If aluminium cables are used, proper coupling with the copper bars must be ensured by using adequate bimetallic cable lugs.



The cable lugs must be installed with an adequate tightening torque (see technical data)



Ensure that all contact surfaces are not oxidised in order to even avoid overheating by contact! If oxidation is observed, the contact must be cleaned using sandpaper.

Ensure that the range of cables and their lengths have been correctly dimensioned in order to avoid dangerous overheating!

Final operations



If connections to the communication and control board are required (e.g.: connection of a monitoring device), refer to the next section before attempting the following instructions.

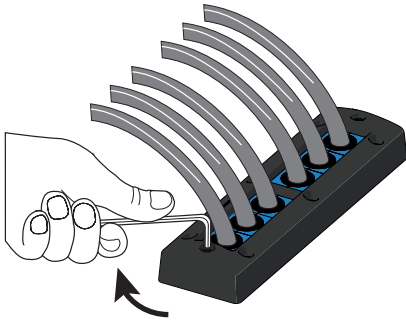

In order to preserve the inverter IP isolation rating, the two locking screws on each cable gland frame must be tightened using the supplied Allen key (5-7 Nm recommended torque). In this way the integrated compression system will secure the cables.



Once all the DC input cables are installed, the cover plates must be mounted again and locked in place using the latches ²¹, then the AC door ⁸¹ must be closed.



Keys for opening must be kept in a place accessible to authorised installation and maintenance operators!



Connections to the communication and control board

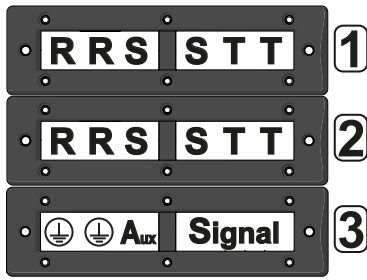

The communication and control board ⁶⁴ is located inside the AC and user interface compartment ¹¹. The signal connection cables for the board must pass through the appropriate AC cable glands ⁷⁸ (block 3 - Signal).

Then the cables must be run into the auxiliary panel ⁶³ through the appropriate signal conduit ⁷⁷.



The conduit protects the cables from any undesired contact with the AC output bus bars ⁷³ or other components which may be at high temperatures and could damage the insulation of the cables.

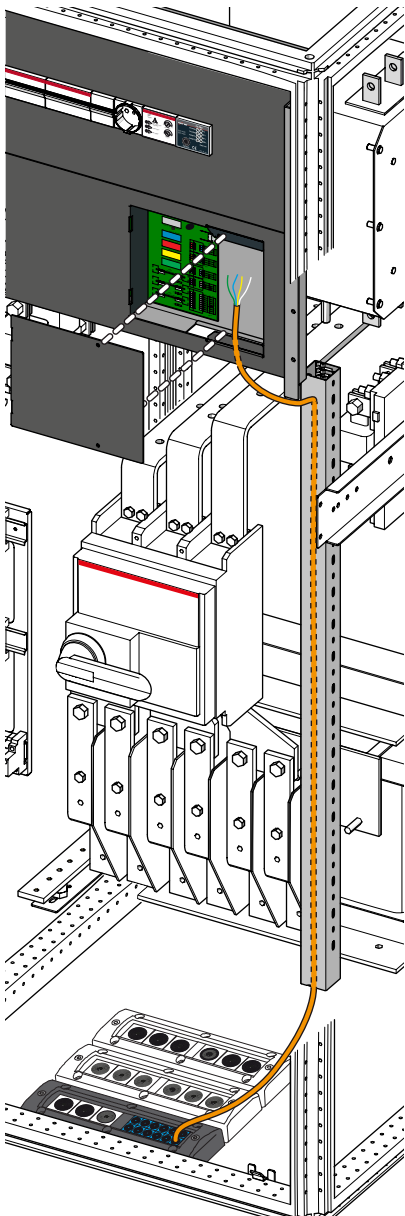

In order to access the signal connection terminals, one must remove the cover of the communication and control board ⁶⁰ by unscrewing the two fixing screws.

The aperture for passing the cables is in the lower part of the housing:

Each terminal accepts a cable cross-section of 0.14 mm² to 1.5 mm². Each cable must be installed with the correct tightening torque (see technical data).

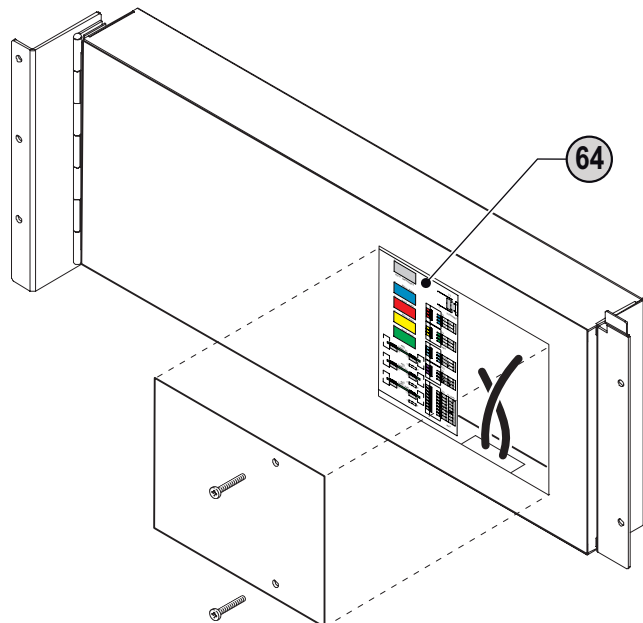

Communication and control board

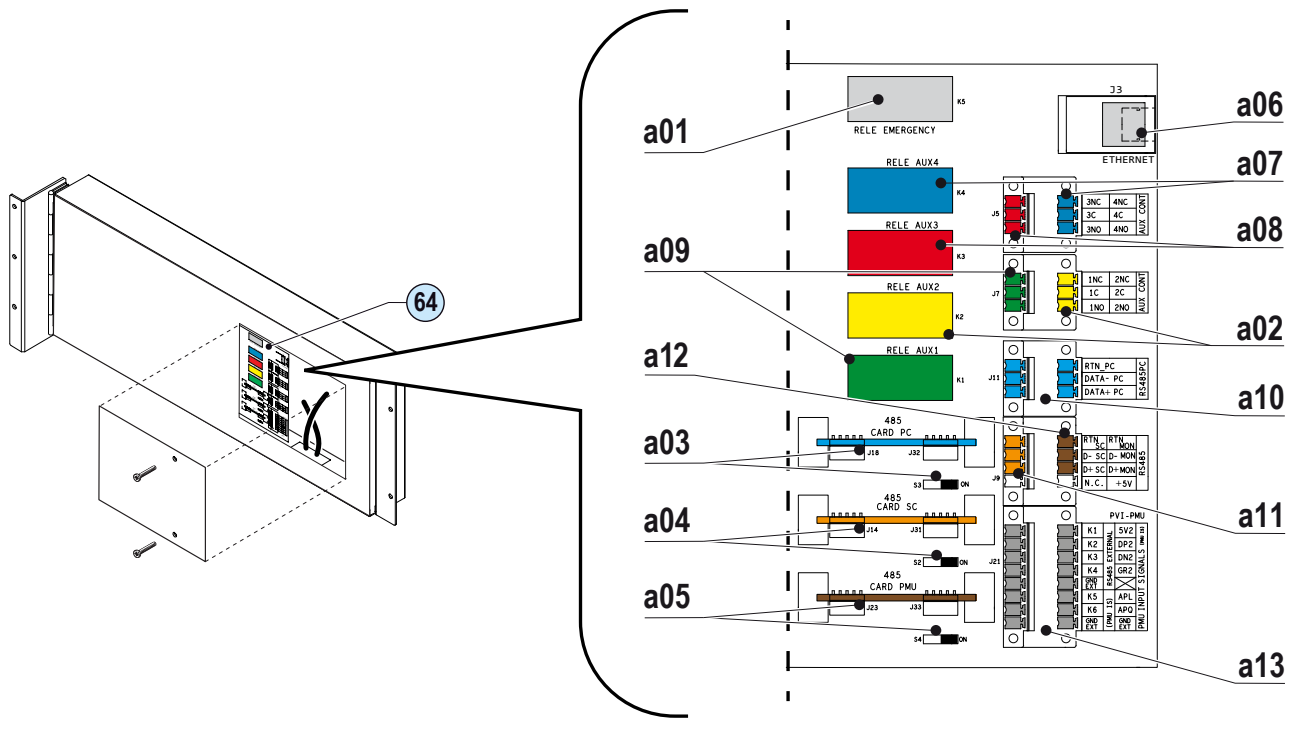

communication and control board (64)

Ref.	Description
a01	Internal emergency relay, not available for other functionalities
a02	Connections and corresponding relay of the 2nd auxiliary contact
a03	Communication board (removable) for RS485PC serial line with corresponding switch for setting the termination resistance of 120 ohms
a04	Communication board (removable) for RS485SC serial line with corresponding switch for setting the termination resistance of 120 ohms
a05	Communication board (removable) for RS485PMU/MON serial line with corresponding switch for setting the termination resistance of 120 ohms
a06	Ethernet port (NOT ACTIVE)
a07	Connections and corresponding relay of the 4th auxiliary contact
a08	Connections and corresponding relay of the 3rd auxiliary contact
a09	Connections and corresponding relay of the 1st auxiliary contact
a10	RS485PC serial connections for monitoring, power control management, and adjustments made by the ABB service/licensed technician.
a11	RS485SC serial connections for PVI-STRINGCOMB connection
a12	RS485MON serial connections for monitoring and management of the power control
a13	Connections to the PMU installed in the machine

Auxiliary contact connection (AUX CONT)

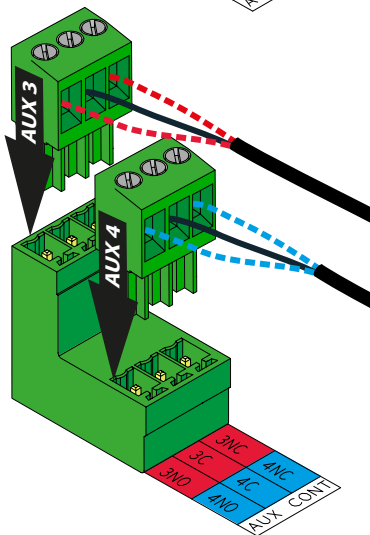
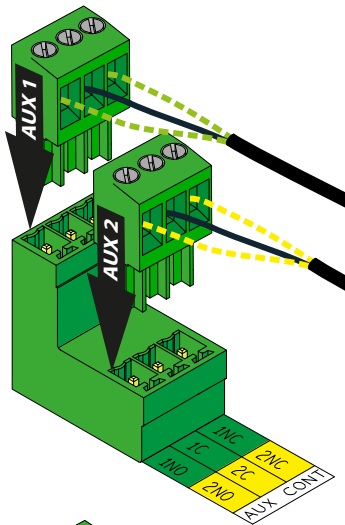
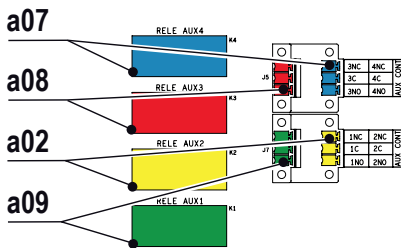

On the communication and control board, ⁶⁴ there are 2 terminal blocks (code AUX CONT) which group the auxiliary contacts (relays) together. There are 4 relays and each one is connected to the operation of the respective conversion module ⁴³:

- Relay AUX1 (corresponding to conversion module 1) a09 contacts with the codes 1C; 1NO; 1NC
- Relay AUX2 (corresponding to conversion module 2) a02 contacts with the codes 2C; 2NO; 2NC
- Relay AUX3 (corresponding to conversion module 3) a08 contacts with the codes 3C; 3NO; 3NC
- Relay AUX4 (corresponding to conversion module 4) a07 contacts with the codes 4C; 4NO; 4NC

The commutation of an individual relay occurs when it goes from a state of connection to the grid to a state of disconnection (or vice versa).

Each contact with code **C** is the COMMON terminal of the relay. Each contact with code **NO** is the terminal corresponding to the NORMALLY OPEN relay contact. Each contact with code **NC** is the terminal corresponding to the NORMALLY CLOSED relay contact.

Under resting conditions (when the inverter is not powered or is disconnected from the grid) contacts C and NC are shorted.

The relays may be connected to systems of warning lights or sounds which indicate any conditions whereby one or more of the conversion modules is disconnected from the grid ⁴³. Such systems must meet the following requirements:

- Maximum Voltage: 250 V AC
- Maximum Current: 8 A
- Conductor cross-section: from 0.14 to 1.5 mm²



RS485 PC serial connection

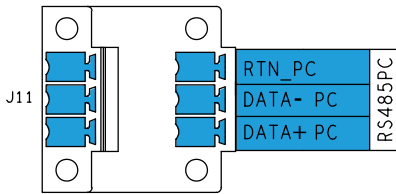

• The terminal block a10 (code RS485PC) is primarily dedicated to connecting a PC equipped with the advanced configuration software “Aurora Central CVI Ultra” through a PVI-USB-RS232_485 signal converter. This serial line is mainly used during the installation phase prior to the configuration of the inverter, and it can be connected in a chain with other inverters in the system.

Alternatively, this port can be used to connect monitoring devices or the power control (PVI-PMU)

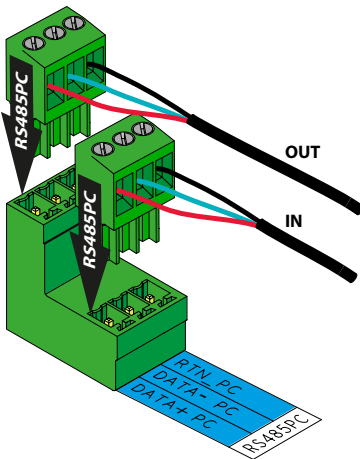

• The two (removable) counterparts on connector J11, where the connections are made, have the usual connection points as shorted on the PCB (gathering board). In this case, the two connectors can be used to form a daisy-chain (“in-out”) from the communication line.

Once the connections are made, insert the counterpart into the connector and lock the two parts by tightening the 2 lateral fixing screws.

• Available contacts: RTN_PC; DATA- PC; DATA+ PC.

• Cable requirements: Conductor cross-section from 0.14 to 1.5 mm²

• Communication protocol: Aurora

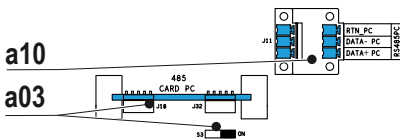

• A substitutable communication board a03 (code 485 CARD PC) and a switch (code S3) are associated with this serial line for setting the termination resistance (120 ohms) of the RS485 line (Position ON resistance activated, position OFF resistance deactivated).

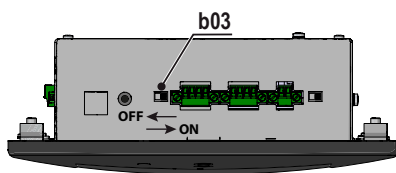

To terminate the RS485PC serial line **it is advisable to use the switch beneath the display** without altering the (OFF) position of the S3 switch previously described.

• RS485PC serial line connection diagram

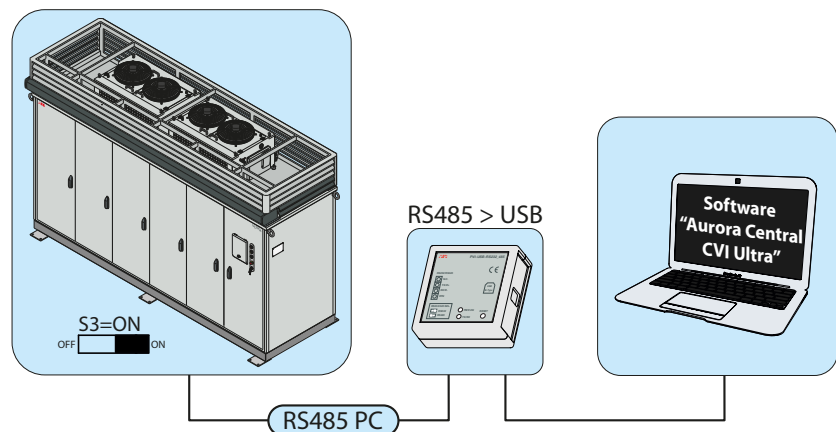

RS485 SC (PVI-STRINGCOMB) Serial Connection

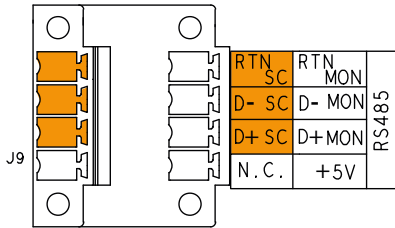

- The terminal block a11 (code RS485SC) is dedicated to the connection of the serial line for the PVI-STRINGCOMBs (connected in a daisy-chain formation) for monitoring operations, and it cannot be connected in a chain with other inverters in the system (for more details consult the PVI-STRINGCOMB manual).

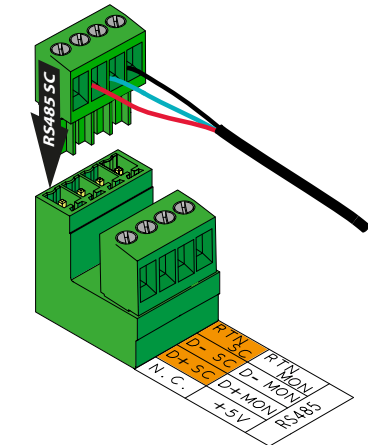

- The counterpart (removable) on connector J9, where connections are made for the RS485SC communication line, is the upper one. Once the connections are made, insert the counterpart into the connector and lock the two parts by tightening the 2 lateral fixing screws.

- Available contacts: RTN_SC; DATA- SC; DATA+ SC.

- Cable requirements: Conductor cross-section from 0.14 to 1.5 mm²

- Communication protocol: Aurora

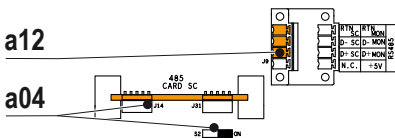

- A substitutable communication board a04 (code 485 CARD SC) and a switch (code S2), are associated with this serial line for setting the termination resistance (120 ohms) of the RS485 line (Position ON resistance activated, position OFF resistance deactivated).

- RS485SC serial line connection diagram

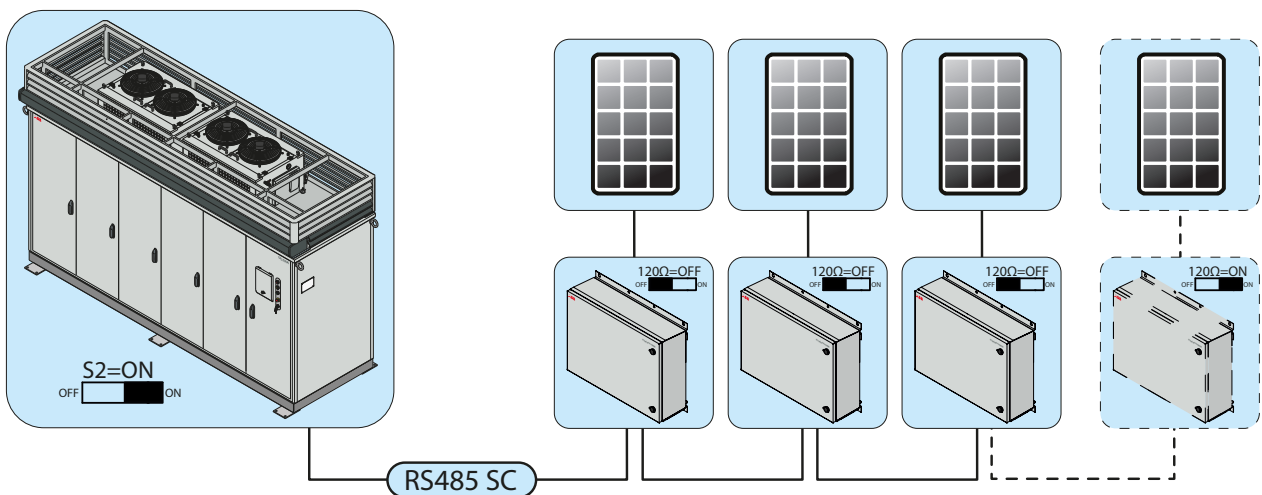

RS485 MON (monitoring system) Serial Connection

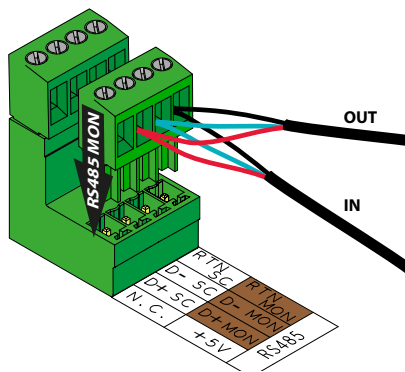
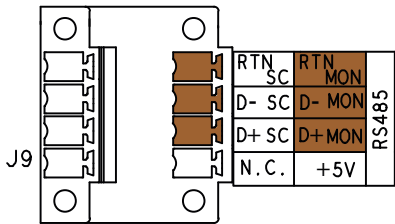

• The terminal block a12 (code RS485MON) is dedicated to connecting a monitoring system.

It allows for the connection of devices which use the proprietary communication protocol Aurora (monitoring or PVI-PMU) or, alternatively, the public protocol ModBus (supervisory control or, alternatively, SCADA data acquisition)

Setting the type of protocol used is carried out with the advanced configuration software "Aurora Central CVI Ultra".

• The (removable) counterpart on connector J9, where connections are made for the RS485MON communication line, is the lower one. In this case, to form the daisy-chain ("in-out") from the communication line the usual terminals should be used which are connected to two cables (one input and one output).

Once the connections are made, insert the counterpart into the connector and lock the two parts by tightening the 2 lateral fixing screws.

• Available contacts: RTN_MON; DATA- MON; DATA+ MON.

• Cable requirements: Conductor cross-section from 0.14 to 1.5 mm²

• Communication protocol: Aurora or ModBus RTU.

• A substitutable communication board a05 (code 485 CARD PMU) and a switch (code S4) are associated with this serial line for setting the termination resistance (120 ohms) of the RS485 line (Position ON resistance activated, position OFF resistance deactivated).

The termination resistance must be activated (ON) only on the last inverter connected to the communication line. When a single inverter is connected to the monitoring device the termination resistance must also be activated.

• RS485MON serial line connection diagram

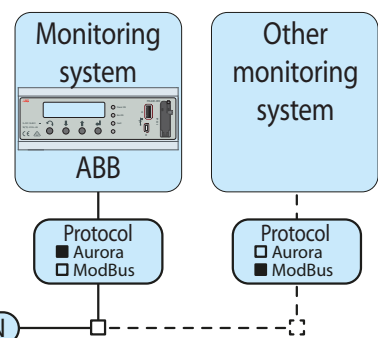
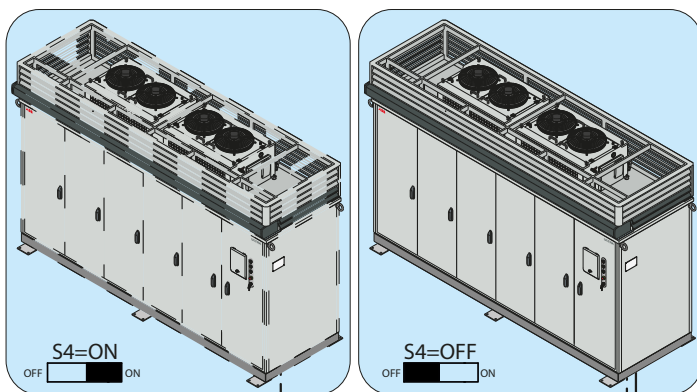
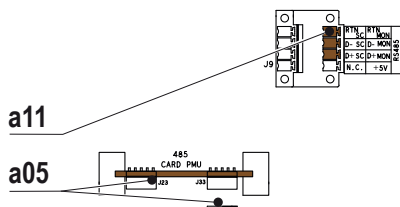

Connections to the power monitoring unit (PMU)

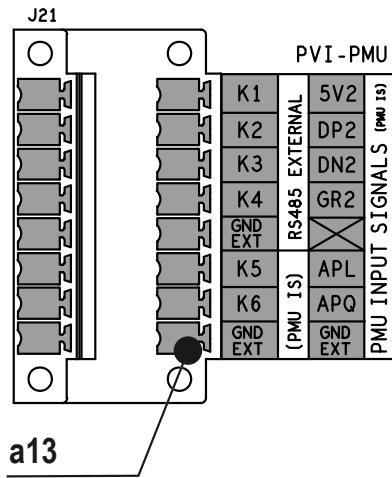

- The terminal block a13 (code PVI-PMU) is dedicated to connecting to the optional PVI-PMU device, which if requested upon placing the order for the inverter will be installed in the machine on the auxiliary panel ⑥3. **If the PVI-PMU device is not installed, then the connections on terminal block a13 should not be used.**

The manager of the grid/client has the option of adjusting the output power and the reactive power feed for the grid through this connection.

- Available contacts:
 - K1, K2, K3, K4, K5, K6: connection to the relays for limiting active power
 - GND EXT (3 terminal blocks)
 - 5V2, DP2, DN2, GR2: RS485 serial connection to the PMU.

If this serial communication line is in use, then the RS485MON line will not be available.

- APL: analogue input for active power monitoring
- APQ: analogue input for reactive power monitoring

Refer to the PVI-PMU product manual for details regarding the operation of the device.

- Cable requirements: Conductor cross-section from 0.14 to 1.5 mm²



General conditions

One of the first rules for preventing damage to the equipment and to the operator is to have a thorough knowledge of the INSTRUMENTS. We therefore advise you to read this manual carefully. If you are not sure about anything or there is discrepancy in information, please ask for more detailed information.



Do not use the equipment if:

- *you do not have suitable qualifications to work on this equipment or similar products;*
- *you are unable to understand how it works;*
- *you are not sure what will happen when the buttons or switches are operated;*
- *you notice any operating anomalies;*
- *there are doubts or contradictions between your experience, the manual and/or other operators.*

ABB cannot be held responsible for damage to the equipment or the operator if it is the result of incompetence, insufficient qualifications or lack of training.

Display and buttons

Description of the display

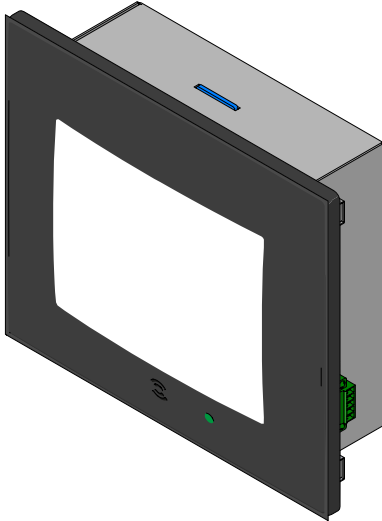

The display (65) is of touchscreen type with 5.7" LCD and is located on the front side of the AC module door, (81) protected by a special cover.

The display allows to simultaneously monitor all the conversion modules (43) that make up the inverter. It is possible to view the following information by navigating in the menu:

- Operating state of each conversion module (43) and related statistical data.
- Operating state of all the PVI- STRINGCOMBs connected to the inverter RS485SC serial line.
- Alarm and fault messages.
- Operating state of the cooling system

The graphical view allows simple and intuitive use by the operator with the option of navigating in the various menus by means of the touch screen.

Description of warning lights and switches on the front door

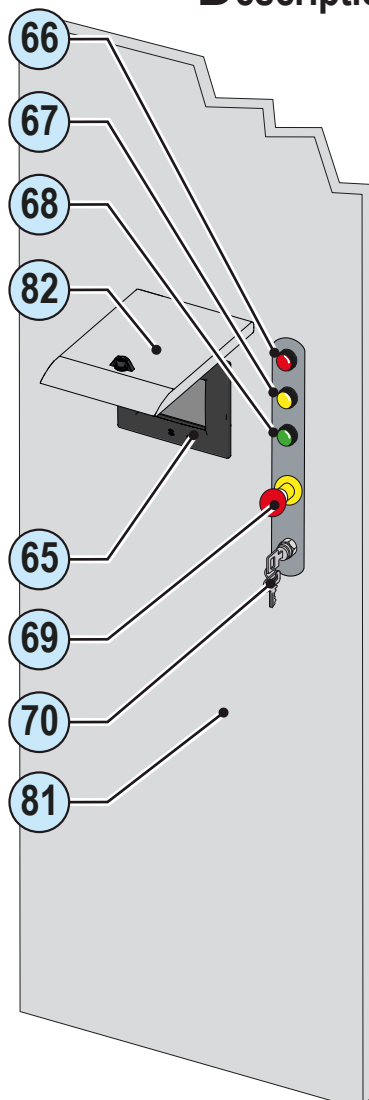

The following items are located next to the display (65):

Red WARNING LIGHT: The red warning light (66) signals that the inverter reported a malfunction that prevents the connection of the inverter or conversion module (43) to the grid.

Yellow WARNING LIGHT: The yellow warning light (67) signals that the inverter reported a malfunction that does not prevent the connection of the inverter to the grid.

Green WARNING LIGHT: The green warning light (68) indicates the inverter status. In particular, it signals whether it is connected to or disconnected from the grid.

EMERGENCY: The emergency button (69) is a device that allows to open the inverter internal AC and DC disconnect switches and consequently to “physically” disconnect the PV generator and the link to the distribution grid. **Voltages are always present on the DC or AC side sources (if not disconnected external to the inverter).**

ON/OFF switch: The key switch (70) is a device that can be operated using the supplied keys to perform the software switch-on or switch-off of the inverter. The PV generator and the grid voltage continue to be supplied to the extent that control does not act on switches but only on the internal control of the inverter.

The rear of the AC door ⁸¹ gives access to the rear connections of the display ⁶⁵:

b01 SD card on which the system files **NECESSARY** for the correct operation of the display are stored. Besides, statistical data of the inverter's operation are saved in the memory

b02 Reset button.

b03 Switch for the RS485PC serial 120 Ohm termination

b04 Connector for the serial output of the display.

b05 Connector for the serial input of the display.

b06 5 V DC power supply connector.

b07 ON/OFF switch.

b08 Battery compartment

Unscrew the battery compartment **b08** to access:

- Lithium battery (allows the display to continue operating in the event of power outage)

- Time battery CR2032 (allows to store the settings set on the display in case of an extended power outage).

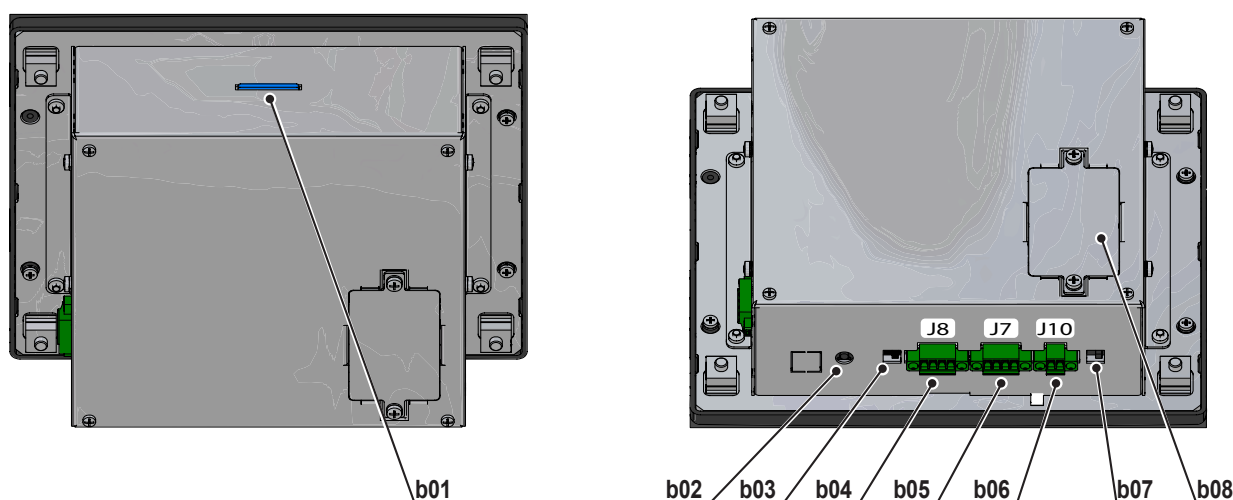

Display status LED indication

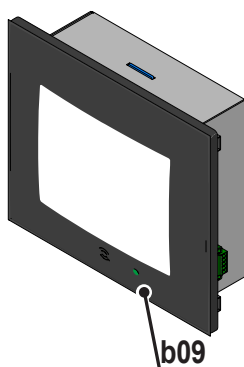

The display ⁶⁵ is equipped with a status LED **b09** that lights up in different colours according to the operating status:

LED OFF: Display off or on without power supply.

GREEN LED ON Battery charged, power connected.

ORANGE LED ON Battery charging.

RED LED: Battery discharged, no power.

FLASHING BLUE LED: Aurora Central PVI Monitor on in Stand-By state.

Auxiliary panel

Description of the panel

The auxiliary panel **63** is installed within the AC and user interface compartment **11** and includes the following devices:

- c01** Auxiliary three-phase line general circuit breaker
- c02** Thermal-magnetic switch powering the conversion modules **43** (1) and (2) and corresponding section of the cooling system
- c03** Thermal-magnetic switch powering the conversion modules **43** (3) and (4) and corresponding section of the cooling system (absent in the 700 kW model)
- c04** Single-phase thermal-magnetic switch for the service socket **c05**
- c05** Single-phase service socket (16 A MAX supplied current)
- c06** Sequence and phase control relay
- c07** PVI-PMU power monitoring unit (Opt.)

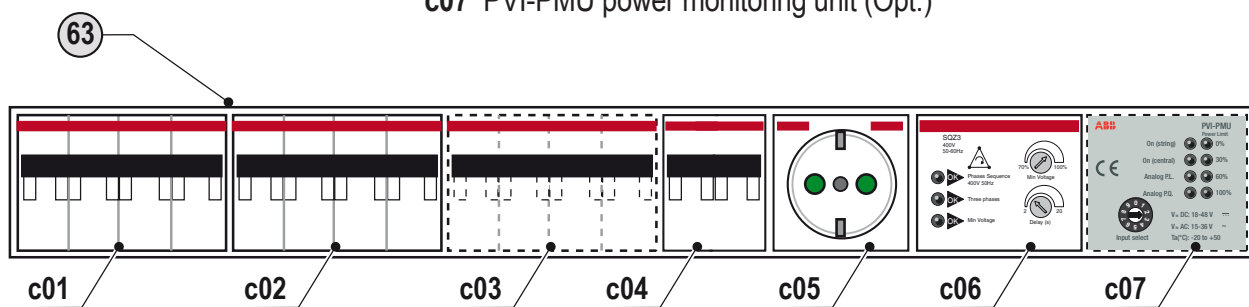

Control relay of phases and sequence

The sequence and phase control relay **c06** continuously monitors the auxiliary line to detect the following:

- incorrect phase sequence
- missing phase
- minimum voltage not reached (adjustable up to 70% of V_n)

Upon reporting one of these three anomalies, the inverter will not start up.

Starting from the top, the first LED indicates the state of the sequence of phases, the second the presence of 3-phase voltage and the third the fact that the minimum input voltage has been exceeded.

Besides, two adjustments are present, one for the value of the minimum voltage and one for the delay of tripping (active only for checking the voltage).

Power monitoring unit (PVI-PMU)

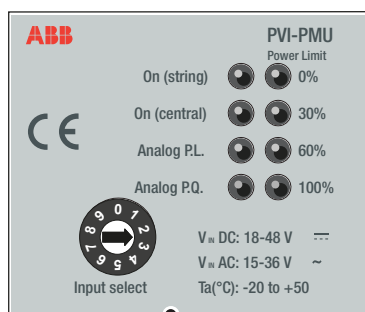

The optional power monitoring unit (PMU) provides the user the option of adjusting the output power and the amount of reactive power fed into the grid.

The LEDs on the panel indicate:

- **On (string)** String inverter mode (not active)
- **On (central)** Centralised inverter mode
- **Analog P.L.** Limitation of active power controlled by analogue input (input I1)
- **Analog P.Q.** Check of reactive power controlled by analogue input (input I2)
- **0 %** Active power limit set to 0% (K4 relay)
- **30 %** Active power limit set to 30% (K3 relay)
- **60 %** Active power limit set to 60% (K2 relay)
- **100 %** Active power limit set to 100% (K1 relay)

A rotary switch is present, which is necessary in the installation phase to configure the mode in which it is possible to check the system (analogue inputs or relay) in the lower part:

Rotary switch	Input	Mode
0	K1,K2,K3,K4	Limitation of active power controlled by relay
1	I1	Limitation of active power controlled by analogue input
2	K1,K2,K3,K4,I2	Limitation of active power controlled by relay and reactive power controlled by analogue input
3	I1,I2	Limitation of active power and check of reactive power controlled by analogue input



“Aurora Central CVI Ultra” advanced configuration software

The ULTRA inverter parameters are set using the “Aurora Central CVI Ultra” advanced configuration software.

Connection of the inverter to the PC on which the “Aurora Central CVI Ultra” software is installed is mandatory during the commissioning phase and requires a PVI-USB-RS232_485 converter.

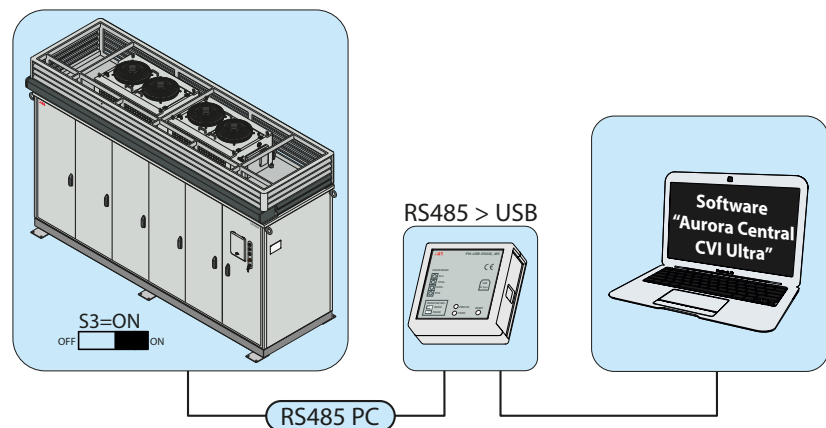

The main software features are:

- serial communication configuration
- adjustment of the active and reactive power feeding into the grid
- access to and download the alarm history
- parameter and status monitoring for the inverter and the individual conversion modules
- switch-off of the inverter and the individual conversion modules via the “remote ON/OFF” command
- access to the inverter identification information
- firmware version check for the devices installed on board the inverter
- assignment of the STRINGCOMB Manager function to one of the conversion modules



Ensure the software is up to date by connecting to the www.abb.com website

General conditions

Before checking the operation of the equipment, it is necessary to have a thorough knowledge of the INSTRUMENTS chapter and the functions that have been enabled in the installation.

The equipment operates automatically without the aid of an operator; operating state is controlled through the instruments.

The interpretation or variation of some data is reserved exclusively for specialized and qualified staff.



The incoming voltage must not exceed the maximum values shown in the technical data in order to avoid damaging the equipment.

Consult the technical data for further details.

Even during operation, check that the environmental and logistic conditions are correct (see installation chapter).

Make sure that the said conditions have not changed over time and that the equipment is not exposed to adverse weather conditions and has not been isolated with foreign bodies.

Monitoring and data transmission

As a rule, the inverter operates automatically and does not require special checks. When the solar radiation is not enough to generate sufficient power to be fed into the grid, (e.g. during the night), the inverter is automatically disconnected and set to stand-by mode.

The operating cycle is automatically restored when there is sufficient solar radiation. The WARNING LIGHTS located on the AC panel  indicate such state.

User interface mode

The inverter is able to provide information about its operation through the following instruments:

- Indication lights (WARNING LIGHTS)
- LCD touchscreen display  to view the operation data
- Data transmission on the dedicated RS-485 serial line. The data can be collected by a PC or a data logger equipped with an RS-485 port. If the RS-485 PC line is used, it may be advisable to use a PVI-USB-RS232_485 serial interface converter for the connection to a PC. Contact the ABB support service for any doubts on device compatibility.

Types of data available

















The inverter provides two types of data, which can be retrieved through the special interface software and/or the display .

Real-time operation data and statistical data can be shown directly on display or transmitted upon request via the dedicated communication line. The free software supplied with the inverter can be used for data transmission to a PC



Commissioning

Preliminary checks with no auxiliary voltage

N.	Description of the check
1	Verify that the DC disconnect switches external to the inverter, normally integrated into the field panels (E.g. PVI-STRINGCOMB), are open
2	Check that the AC disconnect switch external to the inverter (E.g. AC switch internal to the PVI-ULTRA-STATION) is open
3	Check that the auxiliary voltage disconnect switch external to the inverter (E.g. AC switch internal to the PVI-ULTRA-STATION) is open
4	Check that every DC disconnect switch  (one for each conversion compartment ) is open
5	Check that the AC disconnect switch  installed inside the AC and user interface compartment  is open
6	Check that the general disconnect switch and auxiliary voltage sub-disconnect switches (one for every pair of conversion compartments ) are open
7	Check that the key switch  (off/on) is set to "0"
8	Check that the emergency button  is not activated
9	Ensure that all the conductors and protective grounding points are connected and secured with the prescribed tightening torque
10	Ensure that all the DC input conductors are connected and secured with the prescribed tightening torque
11	Ensure that all the AC output conductors are connected and secured with the prescribed tightening torque
12	Ensure that all the DC input conductors are connected and secured with the prescribed tightening torque
13	If the inputs (positive or negative) are grounded, check that: <ul style="list-style-type: none"> - the ground fault fuse  is present and not open - the pole (either positive or negative according to the requested configuration) is connected to ground through the grounding resistor (100Ω). The measurement can be performed between ground and the ground fault fuse 
14	Check that the DC input protection fuses  and the AC output protection fuses  are present, operational and correctly installed
15	Check that the DC  , AC  and auxiliary AC  overvoltage surge arresters are operational and correctly placed
16	Check that all the DC  and AC  cable glands are present and correctly installed



Preliminary checks for the inverter configuration and monitoring

N.	Description of the check
1	Check that the terminating resistors for the RS485 communication lines are correctly set based on the system configuration.

Preliminary checks for the external heat exchangers

N.	Description of the check
1	Check that the front and rear air inlets of the external heat exchangers are clean ⁽³⁰⁾
2	Check that no leaks are present in the connections of the liquid cooling circuit
3	Check that the pressure gauge reading is approximately 2 bar

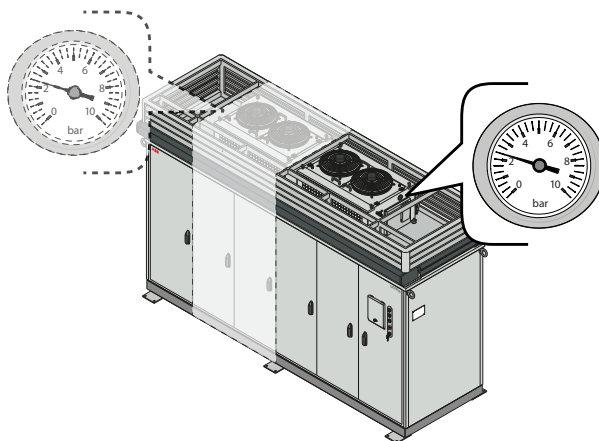

Preliminary checks for the DC, AC output and auxiliary AC voltages

N.	Description of the check
1	Close the auxiliary voltage external disconnect switch and measure the voltage on the terminals inside the AC and user interface compartment ⁽¹¹⁾ . The voltage must be three-phase + neutral (400 V AC phase-phase and 230 V AC phase-neutral). Once the checks are completed, open the external disconnect switch.
2	Check the DC input voltage. Close the DC disconnect switch on the first PVI-STRINGCOMB or parallel panel <u>only</u> and check that the open circuit voltage matches the expected value (based on the design). Further check that no leakage to ground is present by performing measurements between the positive pole and ground and then between the negative pole and ground. The performed measurements must be balanced one to another (for both measurement wait until the voltage reading is stable). Once the checks are completed, open the DC disconnect switch again on the first PVI-STRINGCOMB or parallel panel. Repeat the above operations for all the PVI-STRINGCOMBs or parallel panels in the photovoltaic generator. If a leakage to ground is detected, check each individual string at the input of the PVI-STRINGCOMB or parallel panel to identify the affected string.
3	Close the AC grid voltage external disconnect switch and measure the voltage on the output bars inside the AC and user interface compartment ⁽¹¹⁾ . The voltage must be three-phase (690 V AC phase-phase nominal / 621 to 759 V AC operational range). If the voltage does not match the nominal value, try to adjust its value using the settings on the medium voltage transformer. Once the checks are completed, open the external disconnect switch.

Preliminary checks for the emergency system

N.	Description of the check
1	<p>Check that the emergency button is correctly operational ⑥9 by performing the following:</p> <ul style="list-style-type: none"> - Close the auxiliary voltage external disconnect switch. - Close the main switch <u>c01</u> and the two auxiliary voltage switches <u>C02</u> and <u>C03</u> in the auxiliary panel ⑥3. - Close the DC disconnect switch on each conversion compartment ⑩ present on board ④7. - In the AC and user interface compartment ⑪, close the AC disconnect switch ⑦1. - Press the emergency button ⑥9 and check that: <ol style="list-style-type: none"> a. the red “Alarm” warning light is lit b. the DC disconnect switches ④7 trip into the TRIP position c. the AC disconnect switch ⑦1 trips into the TRIP position - Release the emergency button by rotating it clockwise - Proceed to reset the emergency state by accessing the “Rack Monitor > AC/DC Panel > Reset Emergency” menu on the display - Once the operations are completed, open the DC and AC disconnect switches again



Commissioning procedure

- Close the auxiliary voltage external disconnect switch
- Close the auxiliary voltage main switch c01 in the auxiliary panel ⁶³. This switch feeds the voltage to the two thermal-magnetic circuit breakers (c02 and c03) and to the phase sequence control device.

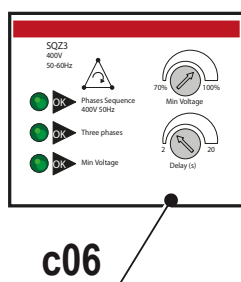
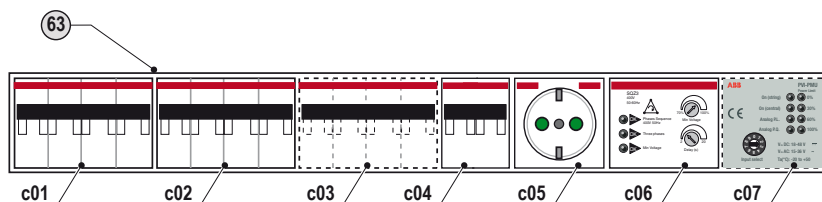

- Check that the 3 LEDs on the phase sequence control device are lit.
 - If the “Phase Sequence” LED is off, the phase sequence is wrong and consequently the cooling system will not be correctly operational. In this case, open the switch c01 and invert two phases on the auxiliary voltage connector ⁷⁵.
 - If the “Three phase” LED is off, one of the phases is missing and consequently the powered devices will not be operational. In this case, open the switch c01 and fix the problem before proceeding to the next steps.
 - If the “Min Voltage” LED is off, the voltage value is low. In this case, check the auxiliary voltage value and that the “Min Voltage” regulation trimmer is set to the minimum (70%)
- There is another adjustment for the delay of tripping on the check of minimum voltage. **Under normal conditions, it is NOT necessary to work on this adjustment.**

- Close the thermal-magnetic circuit breaker c02 that feeds the auxiliary voltage to the conversion compartments ¹⁰ 1 and 2 and to the corresponding cooling system. Check the status of the LEDs on the power supply module ⁴⁵ and on the control logic module ⁴⁴ installed on each conversion module ⁴³.

LED status on the power supply module ⁴⁵:

LED	+5 V	+24 V	-24 V	+15 V	-15 V	Vsin
Status	On	On	On	On	On	Off
Colour	Green	Green	Green	Green	Green	Green

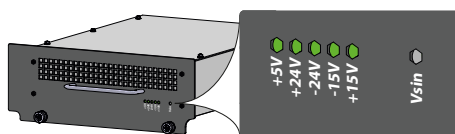

LED status on the control logic module ⁽⁴⁴⁾:

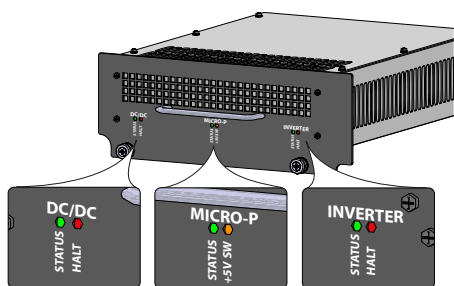

Section	LED	Status	Colour
DC/DC	Status	Flashing	Green
	Halt	Flashing	Red
MICRO-P	Status	Flashing	Green
	+5 V SW	Flashing	Red
INVERTER	Status	Flashing	Green
	Halt	Flashing	Red

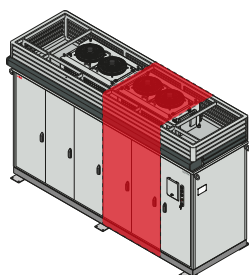

• Repeat the checks in the previous paragraph by closing the thermal-magnetic circuit breaker c03 that feeds the auxiliary voltage to the conversion compartments ⁽¹⁰⁾ 3 and 4 and to the corresponding cooling system.

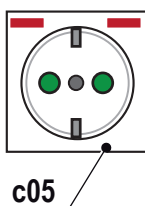

• Check that voltage is present at the service socket c05 on the auxiliary panel ⁽⁶³⁾

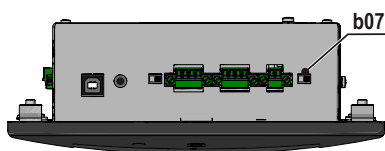

• Switch on the main display by turning the ON/OFF switch b07 on the rear of the display ⁽⁶⁵⁾ (lower side) to **ON**.

This procedure is carried out only upon first start-up in the commissioning phase. The main display will be active after about 60 seconds. The display is factory set to acquire data from the conversion modules and external heat exchangers.

The data capture from the PVI-STRINGCOMBs must instead be configured following the procedure provided in the display menu description (“Service > StringComb Manager” menu)

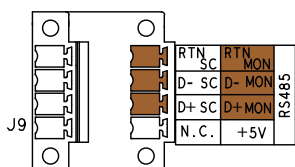

• In case of a monitoring system with more than 1 ULTRA inverter connected in chain on the RS485MON communication line, perform the RS485 address assignment procedure by following the instructions provided in the display menu description (“Settings > Configuration Wizard” menu)

If a ModBus monitoring device is used, the communication line must be properly configured using the Aurora CVI-ULTRA software

• Close the DC input voltage external disconnect switches in the string parallel panel (E.g. PVI-STRINGCOMB).



- Close the AC output voltage external disconnect switch.
- For each conversion compartment ⑩ on board, check the presence of Plexiglas protective systems, close DC disconnect switch ④⑦ and close the door. Start up the first module on the left and continue in sequence.
- Check the presence of Plexiglas protective devices in the AC and user interface compartment ①①, close the AC disconnect switch ⑦① and close the AC door ⑧①.



The inverter is now connected on both the DC and AC sides, in the off state imposed by the key switch position ⑦① (set to "0").



Check that all the doors are correctly closed as the inverter cannot connect to the grid for safety reasons if the safety switches ①③ detect an open door.

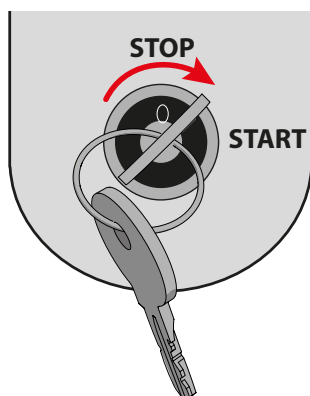

- Set the key switch ⑦① to position "1"

- The inverter starts the initialisation sequence and performs all checks necessary for the connection to the distribution grid. If the input and output parameters are respected, power feeding into the grid starts. The inverter general status can be shown on the main screen of the display ⑥⑤ (refer to the next section).



Using the display and menu structure

The display ⁶⁵ is equipped with a touchscreen that allows to navigate through the menus.

The main screen summarises the system data, the overall operation state and that of each individual conversion module ⁴³. Namely, the available information is:

Date and time
 Power source: grid / battery (with charge indication)
 Communication and control board ⁶⁴.
 Conversion modules operating state ⁴³ indicated by a coloured line as follows:

- GREEN : Module connected and operational
- YELLOW : Module on but not connected to the grid
- RED : Module alarm
- BLUE : Inverter off

 Total energy produced by the inverter and equivalent earnings
 CO2 emissions saving
 Instantaneous power generated
 Energy produced daily by the inverter and equivalent earnings

SN XXXXXX
 EXXX
 RackN 1 M
 ADD 03

It is possible, by touching the individual icons that represent the conversion modules, ⁴³ to display the identification and state information associated with the corresponding module.



Vin XXX.0V
 Iin XXX.0A
 Pin XXX.0kW
 V RS XXX.0V
 V ST XXX.0V
 V TR XXX.0V

It is possible, by tapping anywhere on the lower part of the display (where the inverter summary data is shown), to display a graph of the instantaneous power and the main data relative to the input and output of the complete inverter (SYS tab) or the individual conversion modules ⁴³ (tabs I.1, I.2 and according to the output power I.3 and/or I.4).

The bar in the lower part of the display ⁶⁵ gives access to the main menus and corresponding sub-menus, that allow to display, configure or edit the inverter and the display settings.

Statistics Menu



This section allows to display all production data relative to the system over given time periods. The subsections specify the time period over which the production data will be displayed (Total, Partial, Today, 7 Days, 30 Days, 365 Days, User).

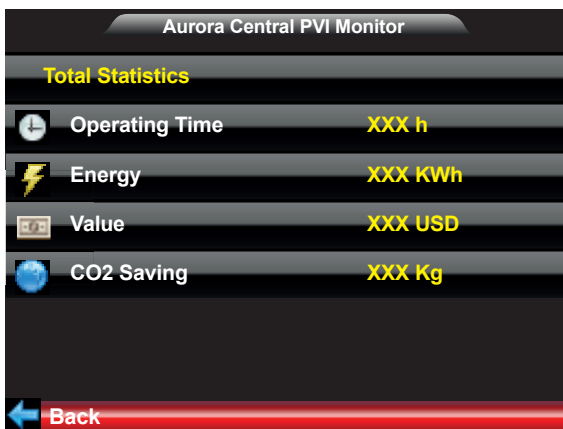

Total

This section displays the overall inverter statistics starting from the first installation.

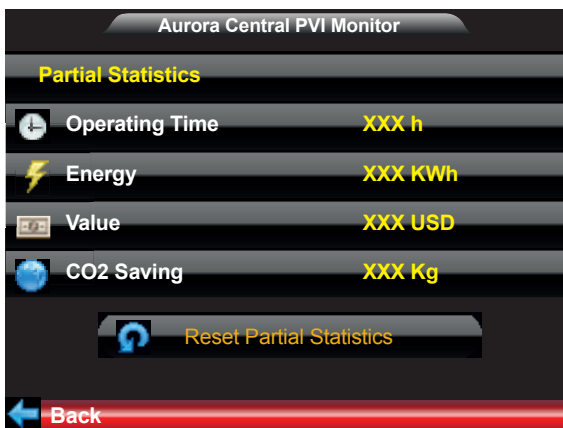

Partial

This section displays the partial statistics.

It is possible to reset all counters in this submenu by tapping the “Reset Partial Statistics” button.

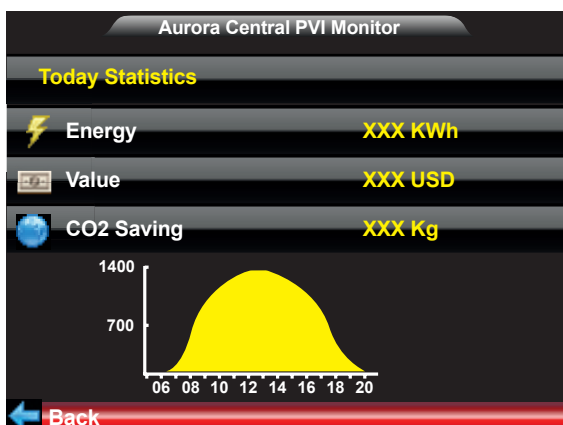

Today

This section displays the daily statistics and a graphical representation of the instantaneous power

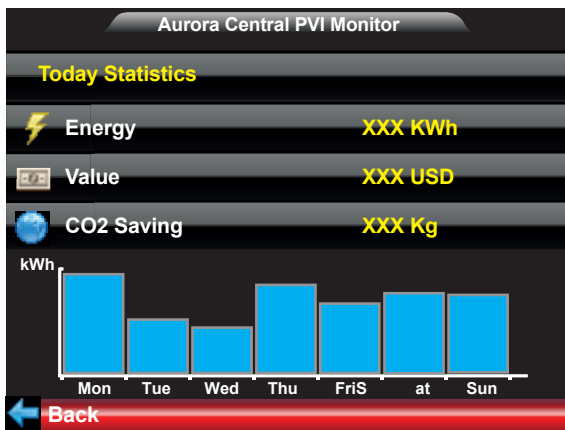

Last 7 days

This section displays the statistics corresponding to the last 7 days and a graphical representation (histogram) of the produced energy.

Last 30 days

This section displays the statistics corresponding to the last 30 days and a graphical representation of the produced energy (see the example screen for the “Last 7 Days”).

Last 365 days

This section displays the statistics corresponding to the last 365 days and a graphical representation of the produced energy (see the example screen for the “Last 7 Days”).

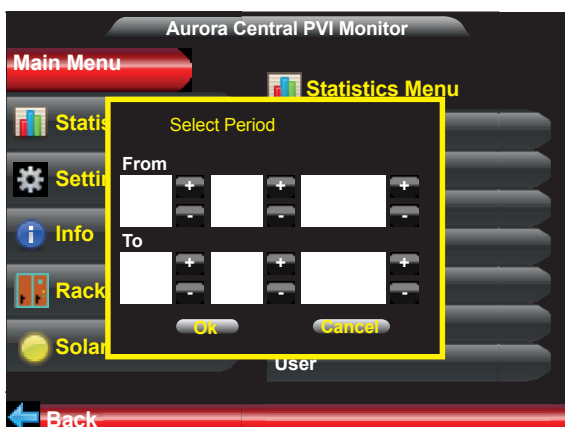

User period

This section displays the statistics corresponding to a user defined period of time. Once this submenu is selected, it is possible to define the start and end dates of the period.



Settings Menu

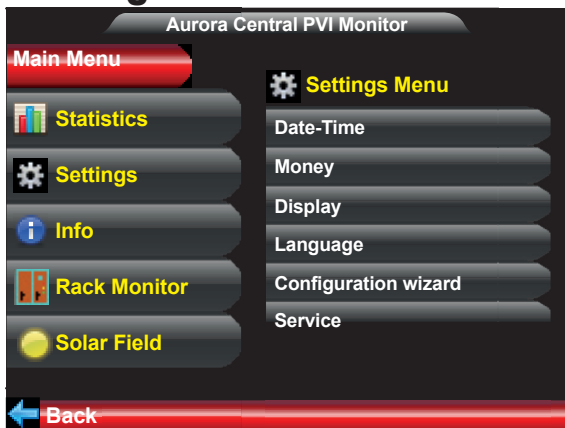

This menu allows to set the inverter and display parameters.

Date/Time

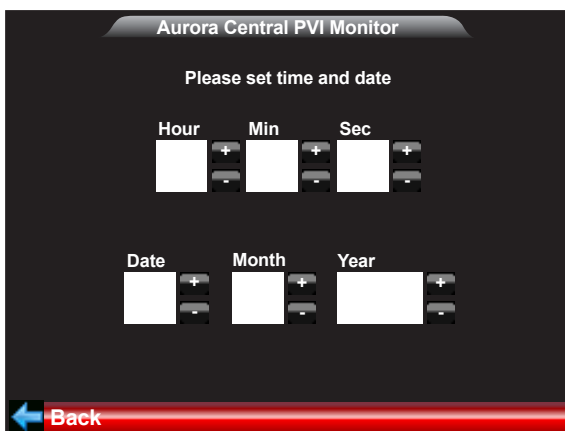

Allows to set the current date and time (daylight saving time not included)

Currency

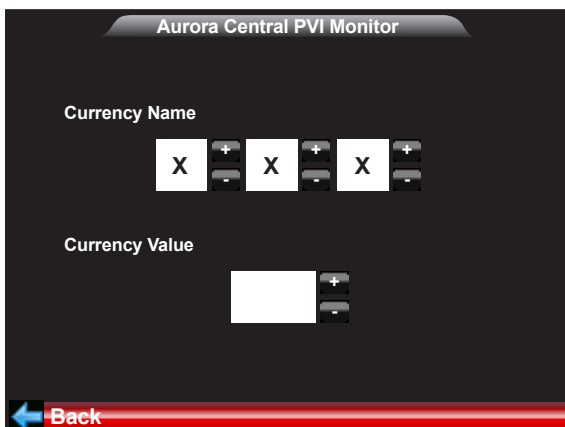

Allows to enter the incentive tariff value (if any) to calculate the obtained earnings, accessible from the statistics menu or the main screen.

Display

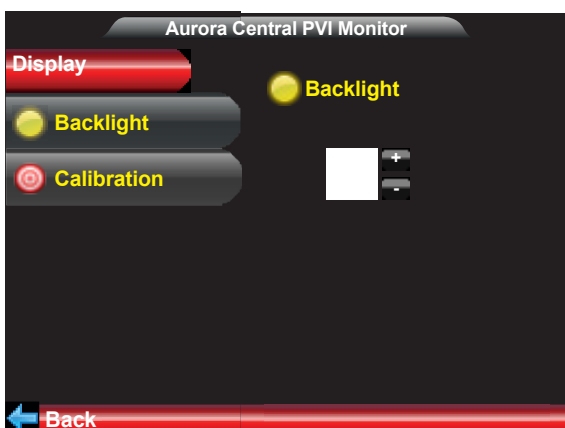

Allows to set the brightness (backlight) on a scale from 0 (min) to 9 (max) and to calibrate the touchscreen



Language

Allows to set the desired menu language

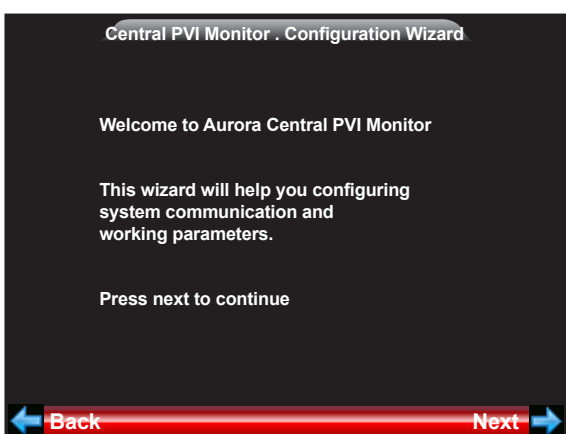

Configuration Wizard

This menu section starts a configuration procedure for the RS485 addresses of the devices on board the ULTRA inverter (display ⁶⁵, communication and control board ⁶⁴ and conversion module ⁴³).

For systems with two or more inverters it is therefore necessary to execute the RS485 address assignment procedure via the display ⁶⁵ in order to assign an absolute address to each conversion module ⁴³.

Tap "Next" to start the acquisition wizard.

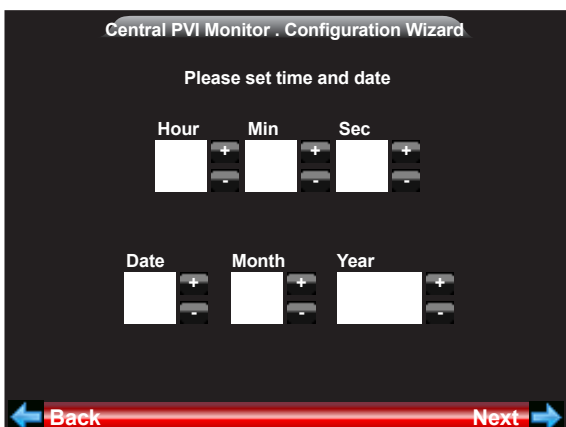

Set the time and date, then tap "Next"

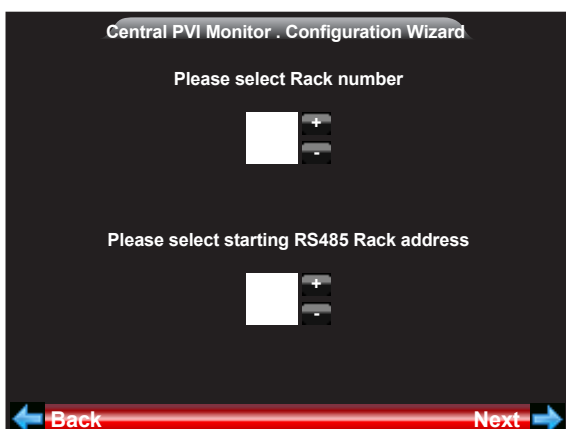

The next screen allows to set the rack number (a number progressively assigned by the installer to the ULTRA inverter) and the RS485 starting address for the devices in the ULTRA inverter on the RS485 bus. The required settings are listed in the following "RS485 addresses" table.

The following table shows the correspondence between the addresses for the devices internal to the inverter (display ⁶⁵, communication and control board ⁶⁴ and conversion modules ⁴³) and the absolute address on the RS485 bus valid for the communication line configuration (RS485 bus).

Table: RS485 addresses

Rack number	Starting RS485PC rack address	Absolute address on RS485 bus	Associated component
1	1	1	Display
		2	Communication and control board
		3	Conversion module
		4	Conversion module
		5	Conversion module
		6	Conversion module
2	7	7	Display
		8	Communication and control board
		9	Conversion module
		10	Conversion module
		11	Conversion module
		12	Conversion module
3	13	13	Display
		14	Communication and control board
		15	Conversion module
		16	Conversion module
		17	Conversion module
		18	Conversion module

*Example: on a system equipped with two ULTRA inverters with 2 internal conversion modules ⁴³ each (ULTRA 700kW), the following parameters must be set:
 "RS485 starting address" must be set to "1" for the first ULTRA inverter
 "RS485 starting address" must be set to "7" for the second ULTRA inverter*

Press Next to proceed with the configuration.



Set the polling period, i.e., the time elapsing between two consecutive statistical data saves in the SD card.

It is advised to set the polling period to 15 minutes

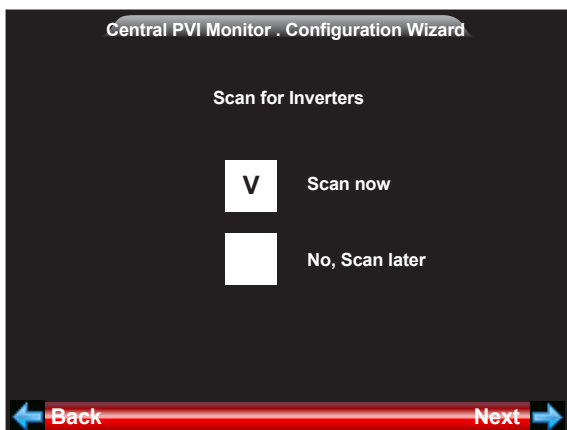

Select “Scan now” to perform scan and detect the devices that require RS485 address assignment

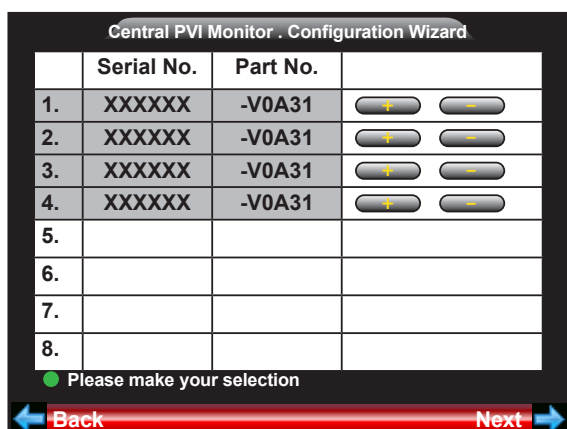

Once the scan is completed, a list of the detected conversion modules (43) is displayed.

Associate the conversion modules (43) using the button. The selected lines will be highlighted in grey.

The communication and control board (64) and the display (65) are automatically associated.

Complete the procedure by tapping “Next” and subsequently confirming the settings changes.



Once the procedure is completed, a system synchronisation will be executed.

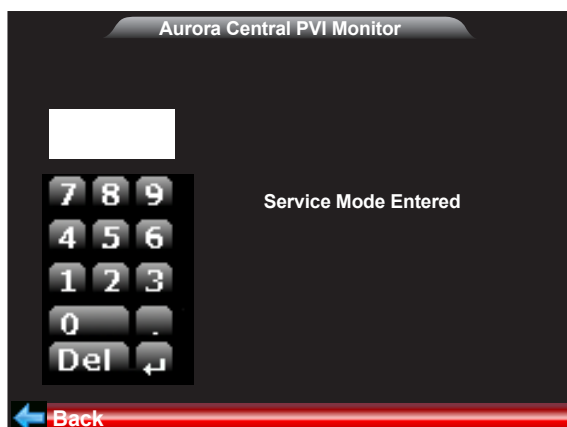

Service

Provides access to the inverter advanced configuration parameters.

Access to this menu is protected by a second level password that can be obtained by registering on the <https://registration.ABBSolarInverter.com> website with the following information:

- Inverter model (E.g.: ULTRA-1400.0-TL)
- Display Serial No. (available in the **Info > ID Central PVI Monitor > Serial No.** menu)

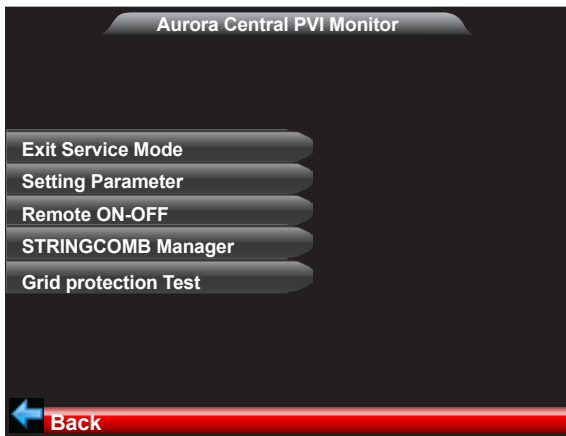

Entering the password allows to access the advanced configuration submenus.

Note: the “Setting Parameter” submenu is currently not available

• Remote ON-OFF

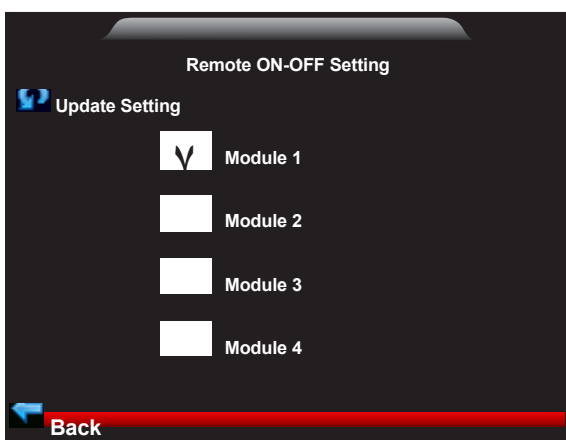

This submenu allows to perform a software switch-off of one or more conversion modules by simply selecting them in the list.

• STRINGCOMB Manager

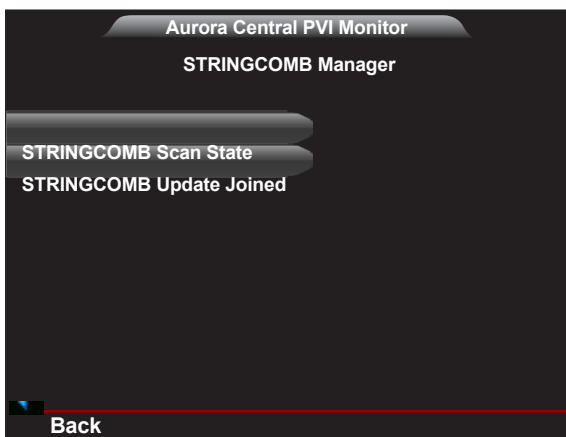

The STRINGCOMB to ULTRA inverter association phase is performed in two steps:

1. Scanning of the STRINGCOMBs connected to the RS485SC line (STRINGCOMB Scan State)
2. Association of the STRINGCOMBs (STRINGCOMB Update Joined)

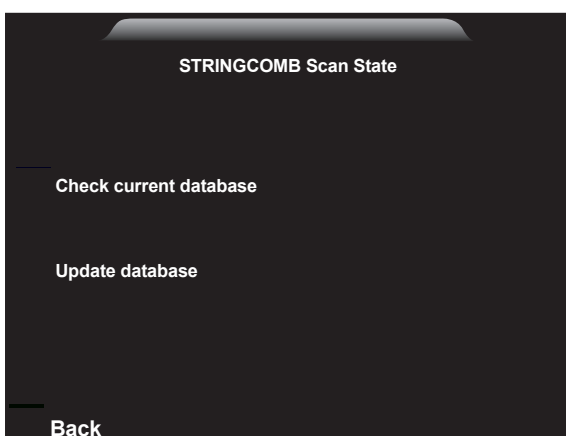

In this step it is possible to check the list of the STRINGCOMBs currently associated to the inverter using the “Check current database” command or to execute a second scan using the “Update Database” command, in order to effectively update the list of the STRINGCOMBs connected to the inverter.

Once the scan is completed, the number of detected STRINGCOMBs will be displayed.

Ensure that the number of detected STRINGCOMBs corresponds to those effectively connected to the ULTRA inverter.

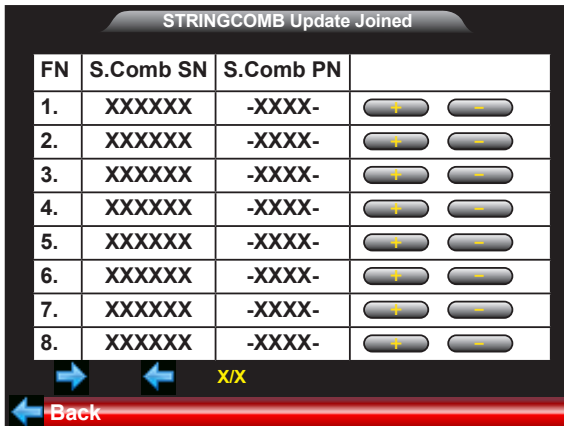

Press “Back”, then “STRINGCOMB Update Joined”. In this way a list of the detected STRINGCOMBs will be displayed (identified by their Serial Number - SN).

Scroll the list to check that the “S.Comb SN” field is present on all the detected STRINGCOMBs. The maximum number of STRINGCOMBs that can be associated is 64.

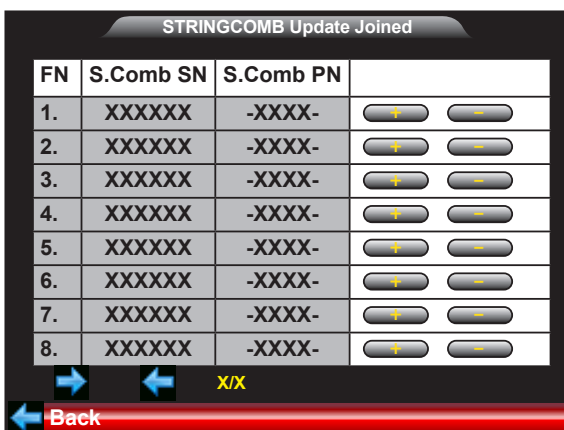

If the checks above have been passed, associate the STRINGCOMBs using the [+] button.

The selected STRINGCOMBs will be highlighted in grey.

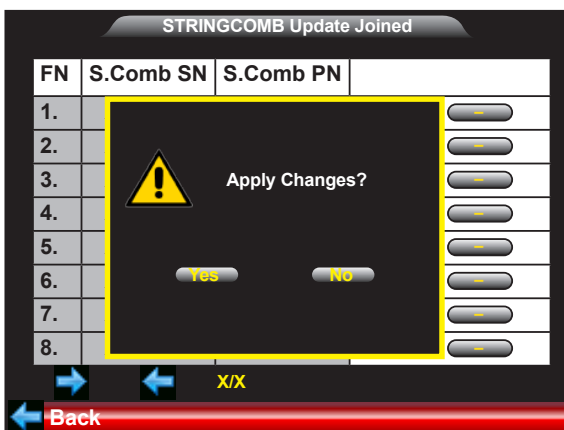

Once all the STRINGCOMBs to be associated to the inverter have been highlighted, tap “Back” and confirm the changes to complete the procedure.



• Grid Protection Test

This menu section is aimed at specialised technicians and allows to select the conversion modules on which to enable grid fault protection tests.

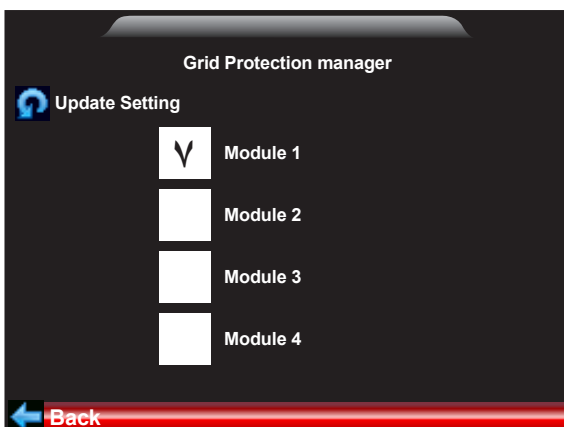

Info Menu

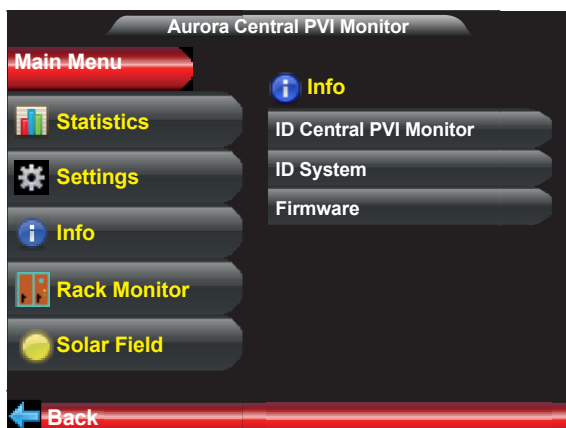

This menu allows to display identification information relative to:

- Display ⁶⁵
- Conversion modules ⁴³
- Display firmware release

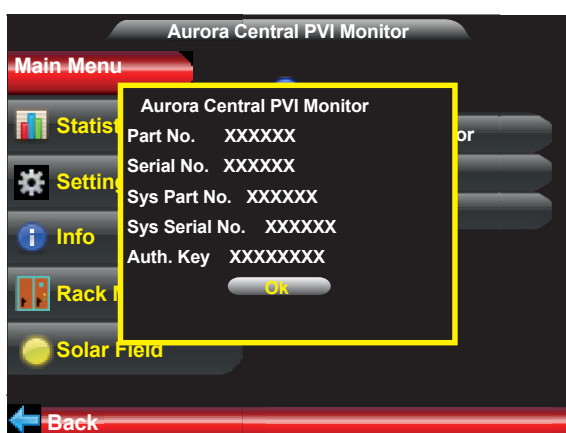

Selecting “ID Central PVI Monitor” the following identification information will be displayed:

- Part No. : Display Part Number
- Serial No. : Display Serial Number (required to request the password for the Service menu)
- Sys Part No. : ULTRA inverter Part Number
- Sys Serial No. : ULTRA inverter Serial Number

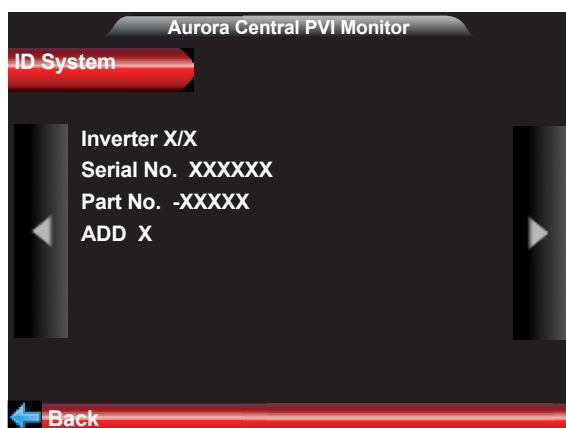

Selecting “ID System” the following identification information relative to the conversion modules ⁴³ will be displayed:

- Inverter X/X : Identification number for the conversion module ⁴³ (modules are numbered from left to right)
- Serial No. : Conversion module Serial Number
- Part No. : Conversion module Part Number
- ADD. : Assigned RS485 address

It is possible to scroll the information screens (one for each conversion module installed on board the inverter) using the arrows on the side of the screen.

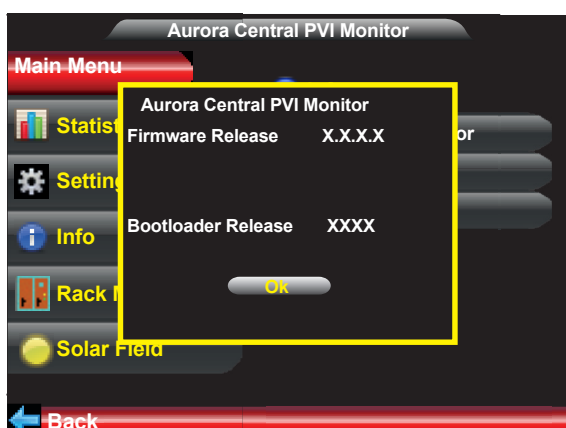

Selecting “Firmware” the display firmware release ⁶⁵ will be displayed

Rack Monitor Menu

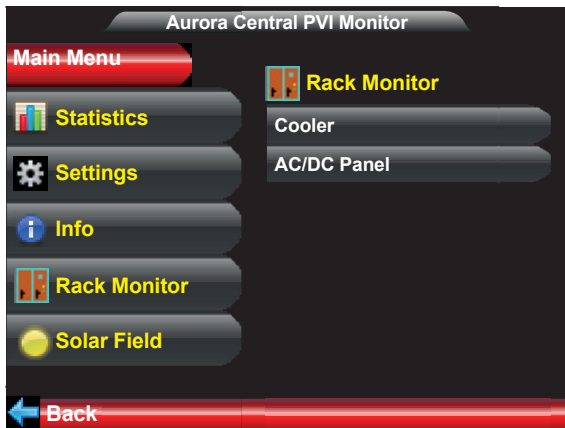

This menu allows to monitor the state of the main parameters of the inverter and cooling system

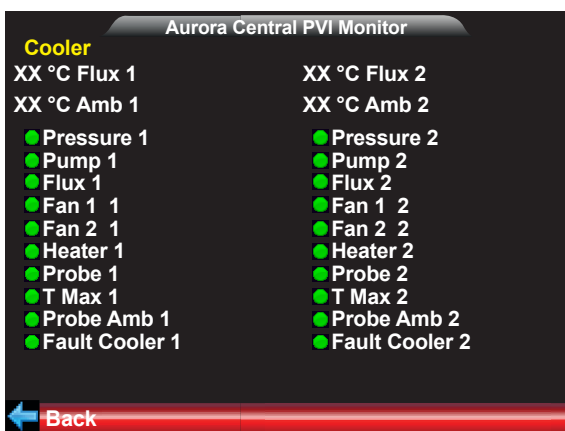

It is possible, by tapping “Cooler”, to display the state of the main components/measurements for each external heat exchanger (on the upper side of the inverter).

An indicator shows the operational state of each measured parameter based on the heat:

- Green indication > correctly operational
- Red indication > malfunction detected.

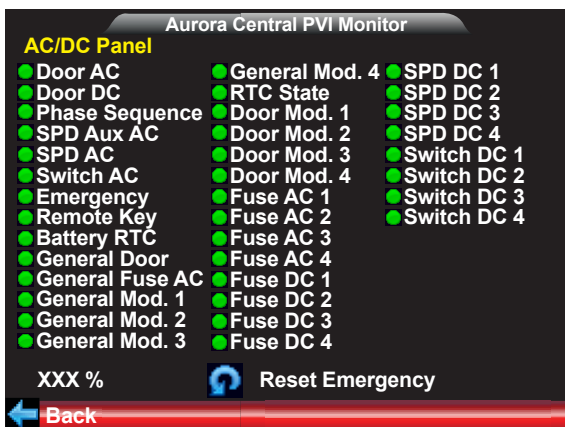

It is possible, by tapping “AC/DC Panel”, to display the state of the main components/measurements internal to the inverter.

An indicator shows the operational state of each measured parameter based on the heat:

- Green indication > correctly operational
- Red indication > malfunction detected.



Solar Field Menu

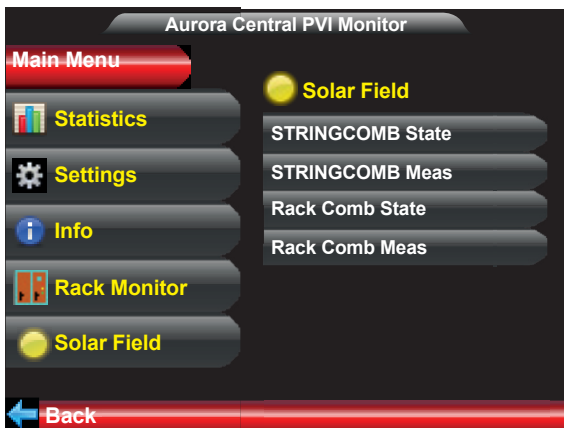

This menu allows to display information relative to the state of the STRINGCOMBs connected to the inverter.

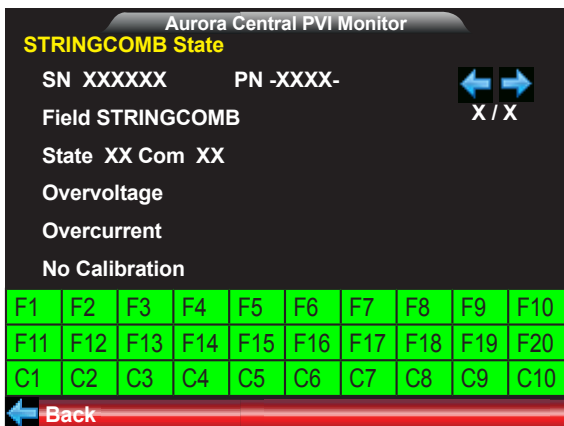

By accessing “STRINGCOMB State”, it is possible to display the alarms (if any) on each individual STRINGCOMB installed on the photovoltaic generator.

Identification and overall state information relative to the STRINGCOMB is available in the top part of each screen. The parameters corresponding to the state of the protection fuses and the input currents of each individual string are monitored in the lower part of each screen. If the parameter is highlighted in red, this means that a fuse is open (fields marked with F) or that a current is unbalanced (fields marked with C)

It is possible to scroll the screens using the arrows that show the progressive number of the displayed STRINGCOMB

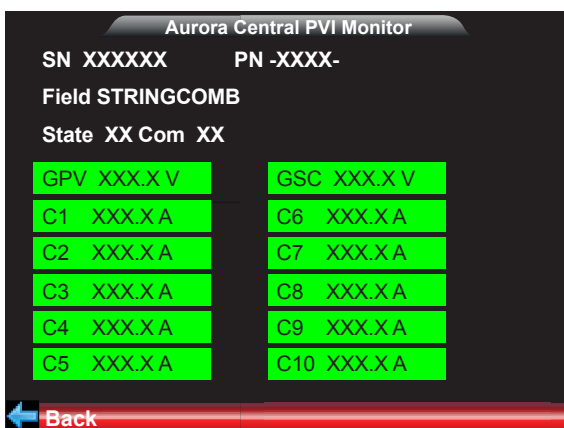

It is possible, by accessing “String Comb Meas”, to display the input values (voltages and currents) of each STRINGCOMB.

Status lights (WARNING LIGHTS) behaviour

- = WARNING LIGHT on
- ⊗ = WARNING LIGHT flashing
- ⊗ = WARNING LIGHT off
- (x) = Any one of the conditions described above

The following table shows all the possible activation combinations of the status lights according to the operating status of the inverter.

The front panel of the AC and user interface compartment ⁽¹¹⁾ is equipped with three warning lights: red warning light ⁽⁶⁶⁾, yellow warning light ⁽⁶⁷⁾ and green warning light ⁽⁶⁸⁾.

Table: Behaviour of WARNING LIGHTS

W A R N I N G LIGHTS status	Operating state	Notes
green: ⊗ yellow: ⊗ red: ⊗	COMMUNICATION ERROR: Loss of communication within the inverter	Loss of communication between conversion modules and/or display to the communication and control board
green: ⊗ yellow: ⊗ red: ⊗	STAND-BY: Initialisation phase of the inverter	Transition state in which the inverter is waiting for sufficient sunlight irradiation to start exporting energy to the grid. During this phase, the inverter checks the conditions necessary for connection to the grid (value of input voltage, value of grid voltage, etc.).
green: ⊗ yellow: ● red: ⊗	STAND-BY with WARNING Inverter initialisation phase in the presence of an anomaly (warning: W warning codes)	Transition state in which the inverter is waiting for sufficient sunlight irradiation to start exporting energy to the grid. During this phase, the inverter checks the conditions necessary for connection to the grid (value of input voltage, value of grid voltage, etc.) even if it has detected an anomaly which could limit its functionality. The inverter shows the warning message detected on the display (codes indicated with Wxxx).
green: ● yellow: ⊗ red: ⊗	RUN: The inverter is connected and feeds power into the grid	The inverter is operating normally. During this phase, the inverter automatically searches the maximum power point (MPP) available from the PV generator.
green: ● yellow: ● red: ⊗	RUN with WARNING: The inverter is connected and feeds power into the grid with the presence of an anomaly	The inverter is connected to the grid and an anomaly is detected. The yellow LED is steadily lit and the display shows the corresponding warning message (codes indicated with Wxxx), which may be internal or external to the inverter
green: ⊗ yellow: ⊗ red: ●	INVERTER ALARM: Inverter internal malfunction detected	Indicates a malfunction that prevents the inverter from feeding power into the grid. The inverter shows the detected error message on the display (codes indicated with Exxx)
green: ⊗ yellow: ⊗ red: ⊗	GRID ALARM: Grid status error detected	Indicates that the grid voltage does not comply with the parameters dictated by the standards of the country of installation and thus the inability of the inverter to feed power into the grid. The inverter shows the detected error message on the display (codes indicated with Exxx)

For information on warning (Wxxx) and error messages (Exxx), consult Alarm Messages

Inverter switch-off

Two types of inverter turn-off are possible: a software switch-off and a hardware switch-off.



Some parts may be very hot and could cause burns.



Some inverter parts may be subject to voltages that could be hazardous for the operator. Before performing any work on the inverter, follow the procedure for turning off the inverter.

Software switch-off

The inverter software switch-off can be done by turning the key switch ⑦⑩ on the AC door ⑧① to position "0".



This kind of switch-off does not allow any operation on board the inverter as it does not involve physically disconnection of the input and output voltages applied within the inverter.

This kind of switch-off is useful for checks that only require disconnection of the inverter from the distribution grid

Hardware switch-off

The inverter hardware switch-off can be done by opening the internal and external disconnect switches.



Perform a software switch-off before performing a hardware switch-off on the inverter by turning the key switch ⑦⑩ to position "0"

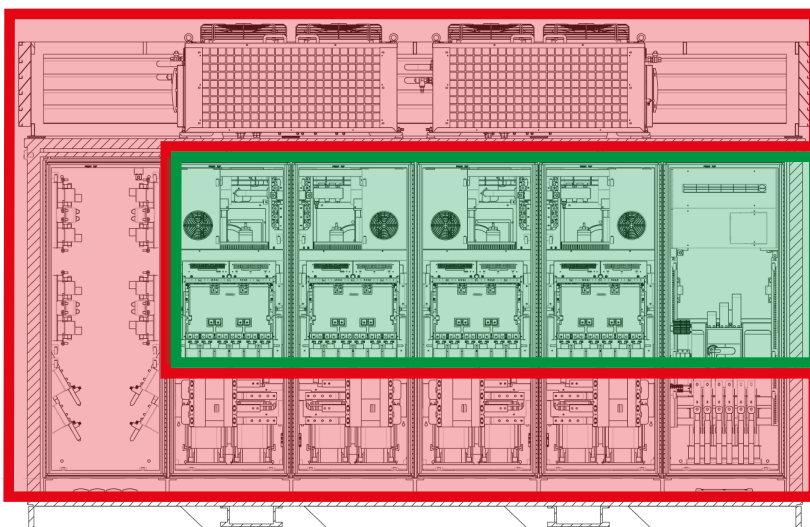

- Open the AC compartment door and open the AC disconnect switch.
- Open the conversion compartments' doors and open the DC disconnect switches.



It is possible in this condition to perform operations within the areas marked in green in the figure below (live parts are marked in red)

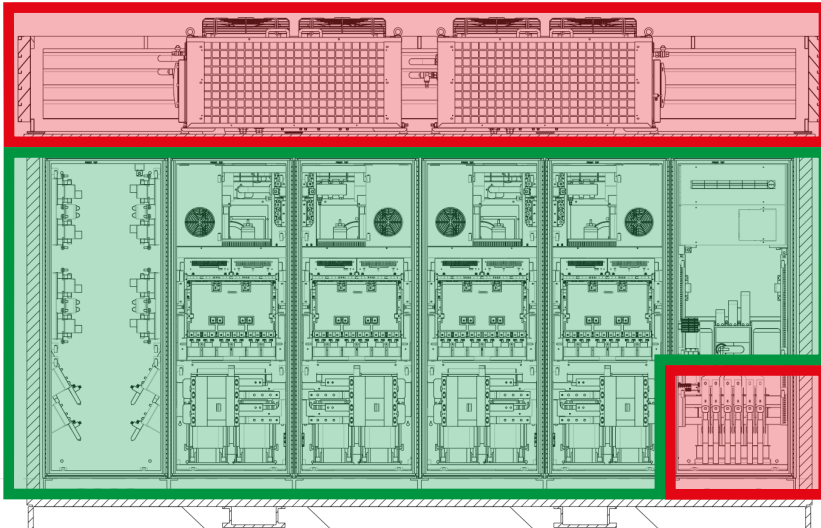

- It is possible, by also opening the external DC disconnect switch upstream the inverter, to perform operations within the areas marked in green in the figure below



It is possible in this condition to perform operations within the areas marked in green in the figure below (live parts are marked in red)

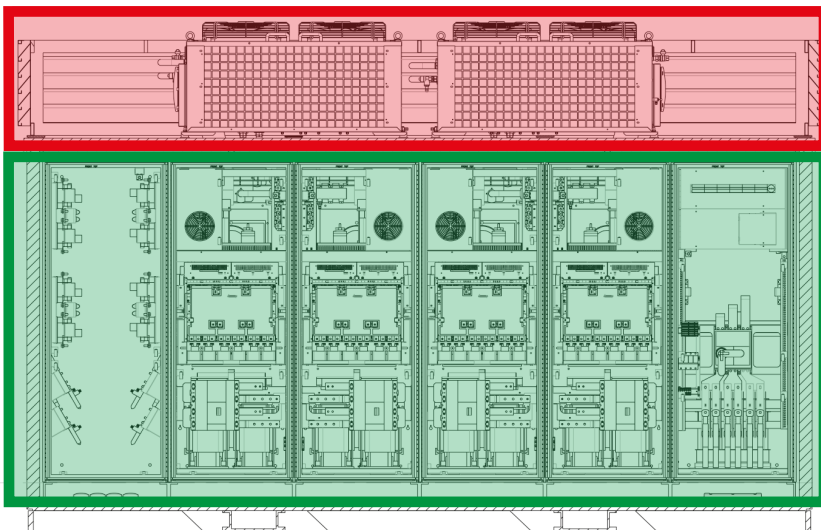

- It is possible, by further opening the external AC disconnect switch upstream the inverter, to perform operations within the areas marked in green in the figure below



It is possible in this condition to perform operations within the areas marked in green in the figure below (live parts are marked in red)

- It is possible, by also opening the external auxiliary voltage disconnect switch, to perform operations on the entire inverter, as no voltage is present inside the whole device.



Before attempting any work on the inverter, wait enough time for the stored energy to be discharged





General conditions

Checking and maintenance operations must be carried out by specialized staff assigned to carry out this work.



Maintenance operations must be performed with the apparatus disconnected from the grid (power switch open) and the photovoltaic panels obscured or isolated, unless otherwise indicated.



*For cleaning, DO NOT use rags made of filamentary material or corrosive products that may corrode parts of the equipment or generate electrostatic charges.
Avoid temporary repairs. All repairs should be carried out using only genuine spare parts.
The maintenance technician is under an obligation to promptly report any anomalies.*

DO NOT allow the equipment to be used if problems of any kind are found, and restore the normal conditions correctly or otherwise make sure that this is done.



Always use the personal protective equipment provided by the employer and comply with the safety conditions of the Accident prevention chapter.

Routine maintenance

Routine maintenance can be performed either by an authorised ABB technician under a servicing contract, or a qualified technician. In the latter case, the technician must be trained by ABB.

If not performed by ABB, routine maintenance must be self certified by the client. The relevant documentation can be requested from ABB at any time. ABB further reserves the right to inspect the client system to verify its maintenance conditions and provide the client with the appropriate documentation.

The periodicity of the maintenance operations may vary in accordance with local environmental conditions and the installation



Perform maintenance operations in compliance with all safety regulations

Visual inspections

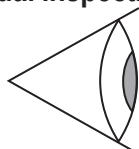

Visually check the cooling system external heat exchangers ³⁰ after 6 months from installation date and every 2 years thereon

- Check that the inverter is correctly operational with no alarm indication
- Verify the general operating status of the external heat exchanger ³⁰
- Check that the front and rear air inlets of the external heat exchanger ³⁰ are clean; if necessary clean the inlets by blowing compressed air from the inside towards the outside
- Check that the air outlets next to the fans of the external heat exchangers ³¹ are clean; if necessary clean the outlets by blowing compressed air from the inside towards the outside
- Check that the display next to the heat exchanger ³⁰ is correctly operational; check the temperature reading and verify that it is appropriate for the ambient temperature and the operating conditions
- Check the warning lights on the AC door ⁸¹
- Turn the key switch to position 0 (check the display to ensure the inverter is in stand-by mode)
- Press the emergency button (the inverter is disconnected both on the DC and AC sides), open the doors to the inverter compartments and check that the disconnect switches are in the trip position (half way between 0 and 1)
- Check that the hydraulic circuit pressure measured by the pressure gauge located on the external heat exchangers ³⁰ falls within 1 and 3 bar



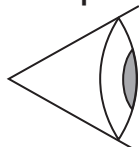

Visual inspections



Visually check the inverter AC and DC compartments after 6 months from installation date and every 2 years thereon

- Check that the inverter internal components are clean, particularly in proximity of the cable glands (both AC and DC) and door gaskets; clean using a vacuum cleaner. Do not use compressed air.
- Check that the non-live metal parts are correctly connected to ground (PV generator frames, metal boxes, doors etc.)
- Ensure all labels and safety signs prescribed in the manual are in place and readable
- Check that the AC and DC surge arresters are correctly operational
- Check that the terminals located on the power connection points do not show colour variations



<p>Actions</p>  <p>Once per year</p>	<ul style="list-style-type: none"> • Check that all power terminals are tightened with the appropriate torque (inverter must be externally disconnected. Refer to the inverter hardware switch-off procedure provided in this manual); the locations subject to inspection are: <ul style="list-style-type: none"> - Connection bars of the DC and AC compartments - 16 conversion module front screws
<p>Cleaning</p> 	<p>If necessary, clean the equipment without using compressed air. Clean using a vacuum system and a damp cloth, especially in proximity of door gaskets</p>
<p>Actions</p>  <p>Once every 5 years</p>	<p>External heat exchangers ³⁰:</p> <ul style="list-style-type: none"> • Replacing the liquid coolant pump • Replacing the liquid coolant • Replacing the expansion vessel • Replacing the pressure switch • Replacing the mechanical thermostat • Replacing the flow switch • Replacing the safety valve <p>Refer to the installation and maintenance manual for information on the replacement procedure.</p>
<p>Actions</p>  <p>Once every 10 years</p>	<p>External heat exchangers ³⁰:</p> <ul style="list-style-type: none"> • External heat exchanger fans ³¹ • Electronic thermostat • 3-way valve • Electric heater • Pressure gauge <p>Alternatively, to minimise maintenance operations (component replacement), it is recommended to replace the entire external heat exchanger ³⁰.</p> <p>Refer to the installation and maintenance manual for information on the replacement procedure.</p> <p>Inverter:</p> <ul style="list-style-type: none"> • Replacing the power supply module ⁴⁵ (one for each conversion module ⁴³) • Replacing the front recirculation fan ⁴² (one for each conversion compartment ¹⁰) • Replacing the rear recirculation fans ⁵⁰ (two for each conversion compartment ¹⁰) • Replacing the cooling assembly fan ³⁵ (one for each conversion module ⁴³)



Troubleshooting

To understand and deal with the warnings (Wxxx) or errors (Exxx) shown on the inverter display, refer to the table shown in the next section.



Operations on the inverter to identify and address any faults may only be performed by the installer or by qualified personnel.

Alarm messages

The equipment signals the following errors/warnings on the display ⁶⁵ only if the auxiliary voltage is present.

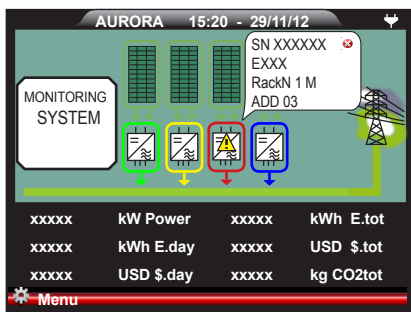

Signalling of messages and corresponding codes is based on the source of the error/warning. If the signal is detected by the communication and control board ⁶⁵ the messages will be shown on the “Monitoring System” icon, whereas if the signal comes from the inverter modules, the messages will be indicated by a red line circling the inverter icon. It is possible to view the error by tapping on the icon.

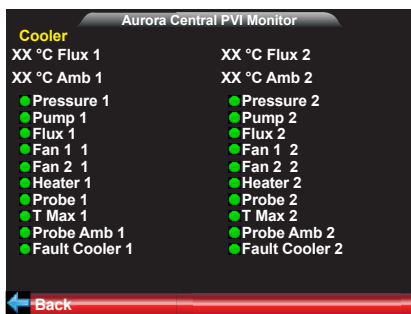

By accessing “Rack Monitor” menu it is possible to check the status of the main parameters of the cooling system (Cooler) and inverter (AC/DC panel), in order to identify the root cause of the malfunction.

An indicator shows the operational state of each measured parameter by its color:
 - Green indication > correctly operational
 - Red indication > malfunction detected.



Display codes	Description	Error/Warning generated by	Cause
E001	Input OC	Conversion module	- Input current exceeding the inverter maximum allowed threshold
E002	Input OV		- High input voltage. One of two possible causes is the incorrect sizing of the PV generator (strings made up of an excessive number of panels in series)
E004	Bulk OV		- Voltage across the bulk capacitors exceeding the overvoltage threshold (internal threshold not editable).
E005	Comm.Error		- Communication error between the inverter internal control devices
E006	Output OC		- Current on one of the output voltage phases exceeding the inverter output overcurrent threshold.
E012	Dc/Dc Fail		- Inverter internal error concerning the operation of the DC-DC circuit part (Booster).
E014	Over Temp.		- Inverter internal temperature exceeding the maximum operating threshold
E015	Bulk Cap Fail		- Loss of insulation on the PV generator - Conversion module internal fault
E016	Inverter Fail		- This alarm is generated when a problem is detected in the inverter circuit part (DC/AC).
E018	Ground Fault		- Ground leakage current detected in the DC section of the system. The alarm is also signalled by the red warning light on the front of the inverter lighting up. - AC leakage currents detected that are associated with the capacitive nature of the photovoltaic generator with respect to ground.
E020	Self Test Error 1		- This is a testing stage error that occurs when the equipment is set to "omologation mode"
E030	Error Meas Ileak		- Error on the internal measurement (performed when the inverter is connected to the grid) of the DC side (PV generator) leakage current with respect to ground (required by regulations) to have a measurement redundancy (2 measurements of the same parameter carried out by two independent circuits)
E033	UTH		- Inverter internal temperature below the minimum operating threshold
E035	Remote Off		- The inverter was remotely switched off (remote OFF) and is waiting for the switch-on signal (remote ON).
E037	Input UC		- Return current detected (from grid to photovoltaic generator)
E039	DC Switch Open		- Open DC disconnect switch - Fault on the auxiliary contact that detects the disconnect switch status - Emergency button activated
E041	AC Switch Open		- Malfunction of one or more AC contactors internal to the conversion compartment - Power supply module (installed on each conversion module) faulty or tripped into protection
E042	Bulk UV	- Voltage across the bulk capacitors below the Under Voltage threshold (internal threshold not editable).	
E044	DC Door Open	- DC compartment door - Safety switch faulty or incorrectly set (not activated by closing the door)	
E045	AC Door Open	- AC compartment door - Safety switch faulty or incorrectly set (not activated by closing the door)	
E047	Anti Islanding	- Inverter internal communication error due to failed reception by the Slave conversion modules of the Anti Islanding pulse sent by the Master module	



Display codes	Description	Error/Warning generated by	Cause
E052	Module door open	Conversion module	- One of the conversion compartments' doors is open - Any of the safety switches on the conversion compartment doors is faulty or incorrectly set (not activated by closing the door)
E048	Liquid Cooler Fail		- Generic alarm state relative to both the external heat exchangers (the error details can be shown on display by accessing the "rack monitor -> cooler" panel)
E803	AC disc switch	Communication and control board	- Open AC output disconnect switch - Emergency button activated
E805	Emergency		- Emergency button activated
E806	Any Door		- This error is shown when the inverter doors are closed and any of the safety switches is faulty or incorrectly set (not activated by closing the door)
E807	Any Fuse		- Indication of a blown fuse (AC or DC). AC grid fault Short circuit on the inverter AC side Internal fault on any of the conversion modules
E808	Alarm Module 1		- Active alarm on conversion module 1 - Emergency button activated
E809	Alarm Module 2		- Active alarm on conversion module 2 - Emergency button activated
E810	Alarm Module 3		- Active alarm on conversion module 3 - Emergency button activated
E811	Alarm Module 4		- Active alarm on conversion module 4 - Emergency button activated
E812	Pressure 1		- Low pressure detected in the hydraulic system of the external heat exchanger (1)
E813	Pump 1		- Faulty coolant recirculation pump of the external heat exchanger (1)
E814	Flow Switch 1		- Leak or obstruction detected by the flow sensor in the cooling circuit of the external heat exchanger (1)
E815	Primary Fan 1		- Faulty or stuck primary fan on the external heat exchanger (1)
E816	Secondary Fan 1		- Faulty or stuck secondary fan on the external heat exchanger (1)
E817	Heater 1		- Damaged internal heater in the external heat exchanger (1) - Thermostat triggering the heater faulty or incorrectly set Activation switch located on the heat exchanger (1) side control panel set to OFF
E818	Probe 1		- Damaged liquid coolant temperature probe of the external heat exchanger (1)
E819	TMax 1		- Temperature of the liquid coolant in the external heat exchanger (1) exceeding the maximum admitted value
E820	Pressure 2		- Low pressure detected in the hydraulic system of the external heat exchanger (2)
E821	Pump 2		- Faulty coolant recirculation pump of the external heat exchanger (2)
E822	Flow Switch 2		- Leak or obstruction detected by the flow sensor in the cooling circuit of the external heat exchanger (2)
E823	Primary Fan 2		- Faulty or stuck primary fan on the external heat exchanger (2)
E824	Secondary Fan 2		- Faulty or stuck secondary fan on the external heat exchanger (2)



Display codes	Description	Error/Warning generated by	Cause
E825	Heater 2	Communication and control board	- Damaged internal heater in the external heat exchanger (2) - Thermostat triggering the heater faulty or incorrectly set Activation switch located on the heat exchanger (2) side control panel set to OFF
E826	Probe 2		- Damaged liquid coolant temperature probe of the external heat exchanger (2)
E827	TMax 2		- Temperature of the liquid coolant in the external heat exchanger (2) exceeding the maximum admitted value
E828	Door Open Mod 1		- Door to the conversion compartment 1 is open
E829	Door Open Mod 2		- Door to the conversion compartment 2 is open
E830	Door Open Mod 3		- Door to the conversion compartment 3 is open
E831	Door Open Mod 4		- Door to the conversion compartment 4 is open
E832	AC Fuse Mod 1		- One of the AC output fuses in conversion module number 1 is blown. The main causes for AC output fuse tripping are: AC grid fault Short circuit on the inverter AC side Internal conversion module fault (short circuit on Es:IGBT)
E833	AC Fuse Mod 2		- One of the AC output fuses in conversion module number 2 is blown. The main causes for AC output fuse tripping are: AC grid fault Short circuit on the inverter AC side Internal conversion module fault (short circuit on Es:IGBT)
E834	AC Fuse Mod 3		- One of the AC output fuses in conversion module number 3 is blown. The main causes for AC output fuse tripping are: AC grid fault Short circuit on the inverter AC side Internal conversion module fault (short circuit on Es:IGBT)
E835	AC Fuse Mod 4		- One of the AC output fuses in conversion module number 5 is blown. The main causes for AC output fuse tripping are: AC grid fault Short circuit on the inverter AC side Internal conversion module fault (short circuit on Es:IGBT)
E840	Liquid Cooler Gen Fault 1		- External heat exchanger 1 generic error. This error is signalled together with any other external heat exchanger error.
E841	Liquid Cooler Gen Fault 2		- External heat exchanger 2 generic error. This error is signalled together with any other external heat exchanger error.
E842	Probe Ambient 1		- Damaged ambient temperature measurement probe inside the external heat exchanger 1
E843	Probe Ambient 2	- Damaged ambient temperature measurement probe inside the external heat exchanger 2	
W003	Grid Fail	Conversion module	- AC grid voltage unbalance detected
W004	Grid OV		- Grid voltage measured by the inverter exceeding the maximum set threshold - High grid impedance (distribution side) - Undersized AC cable cross-section (system side) - Incorrect AC output cables installation
W005	Grid UV		- Grid voltage measured by the inverter below the minimum set threshold - Incorrect AC output cables installation



Display codes	Description	Error/Warning generated by	Cause
W006	Grid OF	Conversion module	- Grid frequency measured by the inverter exceeding the maximum set threshold
W007	Grid UF		- Grid frequency measured by the inverter below the minimum set threshold
W011	Bulk UV		- Conversion module internal error due to a DC/DC circuit malfunction
W015	Grid df/dt		- Grid outage during the inverter operation. In this condition the inverter disconnects from the grid.
W801	Sequence	Communication and control board	- Error during the wiring sequence of the auxiliary power supply phases detected by sequence and phase control relay <u>c06</u>
W802	SPD AC Aux		- Damaged auxiliary line overvoltage surge arresters
W804	SPD AC 1		- Damaged AC power line overvoltage surge arresters
W805	Key Switch		- Key switch set to 0 (STOP)
W806	Battery RTC		- Back-up battery on the communication and control board discharged/faulty
W807	Comm Fault Cooler 1		- Inverter internal communication error between the external heat exchanger 1 and the communication and control board
W808	Comm Fault Cooler 2		- Inverter internal communication error between the external heat exchanger 2 and the communication and control board
W809	RTC fail		- The time set on the communication and control board is not synchronised with the time on the display and conversion modules
W810	Syncro AI		- Inverter internal error on Anti Islanding synchronisation signal
W811	Syncro scan		- Inverter internal error on the MPPT synchronisation signal
W812	PWM Syncro		- Inverter internal error on the PWM synchronisation signal
W813	Comm Fault Int Serial		- Inverter internal communication error (RS485 signal)
W814	Comm Fault Int CAN		- Inverter internal communication error (CAN BUS signal)



Storage and dismantling

Storage of the equipment or prolonged stop

If the equipment is not used immediately or is stored for long periods, check that it is correctly packed and contact ABB for storage instructions. The equipment must be stored in well-ventilated indoor areas that do not have characteristics that might damage the components of the equipment.

Restarting after a long or prolonged stop requires a check and, in some cases, the removal of oxidation and dust that will also have settled inside the equipment if not suitably protected.

Dismantling, decommissioning and disposal

ABB CANNOT be held responsible for disposal of the equipment: displays, cables, batteries, accumulators, etc., and therefore the customer must dispose of these substances, which are potentially harmful to the environment, in accordance with the regulations in force in the country of installation.

If the equipment is dismantled, in order to dispose of the products that it is composed of, you must adhere to the regulations in force in the country of destination and in any case avoid causing any kind of pollution.

Dispose of the various types of materials that the parts of the equipment consist of in dumps that are suitable for the purpose.



Table: disposal of components

COMPONENT	MATERIAL OF CONSTRUCTION
Frame, brackets, supports	Arc-welded steel FE37
Casing or covers	ABS, plastic
Paint and	RAL
Gaskets and seals	Rubber / Teflon / Viton
Electrical cables	Copper / Rubber
Conduits	Polyethylene / Nylon
Back-up battery	Nickel / Lead/ Lithium

Further information

For more information on ABB products and services for solar applications, navigate to www.abb.com/solarinverters

Contact us

www.abb.com/solarinverters